

RESTRICTED - FOR OFFICIAL USE ONLY

B.R. 933 (1945) (RESTRICTED)

HANDBOOK
ON
AMMUNITION

1945

FOREWORD

Nothing in this book is to be taken as an authority for disregarding the orders and regulations laid down in the Naval Magazine and Explosive Regulations, the Naval Cordite Regulations and Naval Air Stations Magazine Regulations. Those publications are the authority for the necessary care and precautions in the stowage, handling and inspection of ammunition of all sorts.

Section 16

~~B109*~~

Cancelled and Superseded

by BR 932 (1965)

Retained for "record and interest"

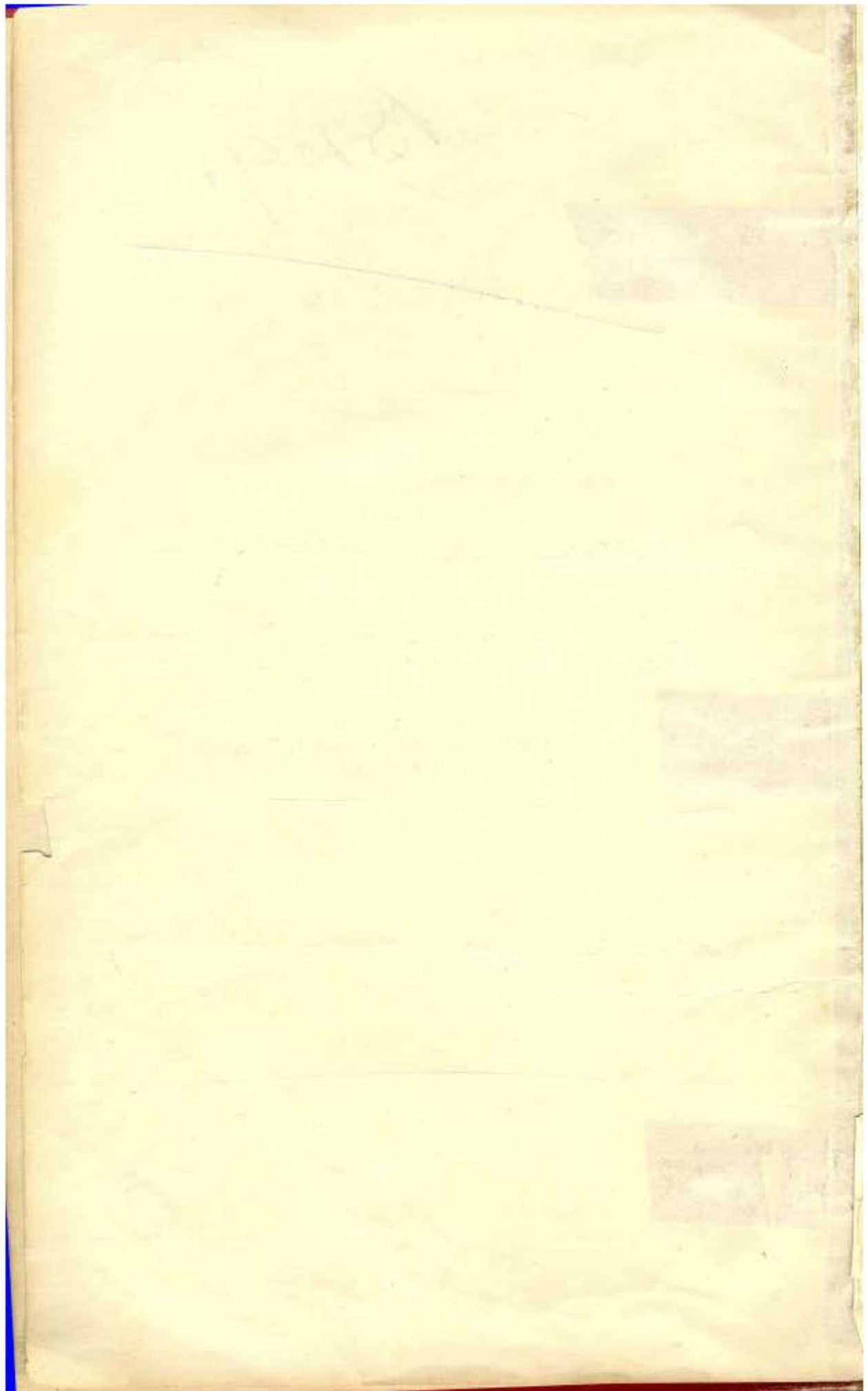

RESTRICTED - FOR OFFICIAL USE ONLY

*RETAINED IN ARCHIVE
LIBRARY.*

B.R. 932 (1945) (RESTRICTED)

HANDBOOK

ON

AMMUNITION

1945

Admiralty, S.W.1
Naval Ordnance Department

Amendment No.	A.F.O. P. No.	Date of insertion in this copy	Initials

Admiralty, S.W.1.
February 3rd, 1945.

G.461/44.

B.R. 932 (1945) (Restricted)—*Handbook on Ammunition*, having been approved by My Lords Commissioners of the Admiralty, is promulgated for information and guidance.

B.R. 932, dated 1935, and C.B. 3032 are hereby superseded and all copies should be disposed of in accordance with *B.R.1—Books of Reference and I.D. Catalogue* and *C.B. Form U2D (1942)*, paragraph 12A (iii).

By Command of Their Lordships,

J. V. Markham

To Flag Officers and Commanding
Officers of H.M. Ships and
Vessels and establishments
concerned.

LIST OF CHAPTERS

- I. GENERAL REMARKS ON EXPLOSIVES.
- II. PROPELLANTS.
- III. HIGH EXPLOSIVES.
- IV. GUNPOWDER AND PYROTECHNIC COMPOSITIONS.
- V. CHARGE WEIGHTS.
- VI. CARTRIDGES FOR B.L. GUNS.
- VII. CARTRIDGES FOR Q.F. GUNS AND AIRCRAFT CATAPULTS.
- VIII. TUBES, VENT.
- IX. PRIMERS.
- X. BLANK CARTRIDGES.
- XI. PROJECTILES.
- XII. SHELL FUZES AND GAINES.
- XIII. SMALL ARMS AMMUNITION.
- XIV. S.A.A. (*contd.*)—1-INCH AIMING RIFLE AND 0.22 INCH.
- XV. S.A.A. (*contd.*)—20-MM. S.A. AMMUNITION.
- XVI. ROCKET PROJECTED DEVICES.
- XVII. GRENADES.
- XVIII. HOLMAN PROJECTORS. B.L. 4-INCH MORTARS.
- XIX. PYROTECHNICS.
- XX. LINE CARRYING ROCKETS AND LINE-THROWING GUNS.
- XXI. AIRCRAFT BOMBS AND COMPONENTS.
- XXII. AMMUNITION PACKAGES.
- XXIII. AMMUNITION EMBARKATION AND SUPPLY.
- XXIV. MAGAZINES AND SHELL ROOMS.
- XXV. WEATHER DECK MAGAZINES AND LOCKERS.
- XXVI. TARGETS AMMUNITION

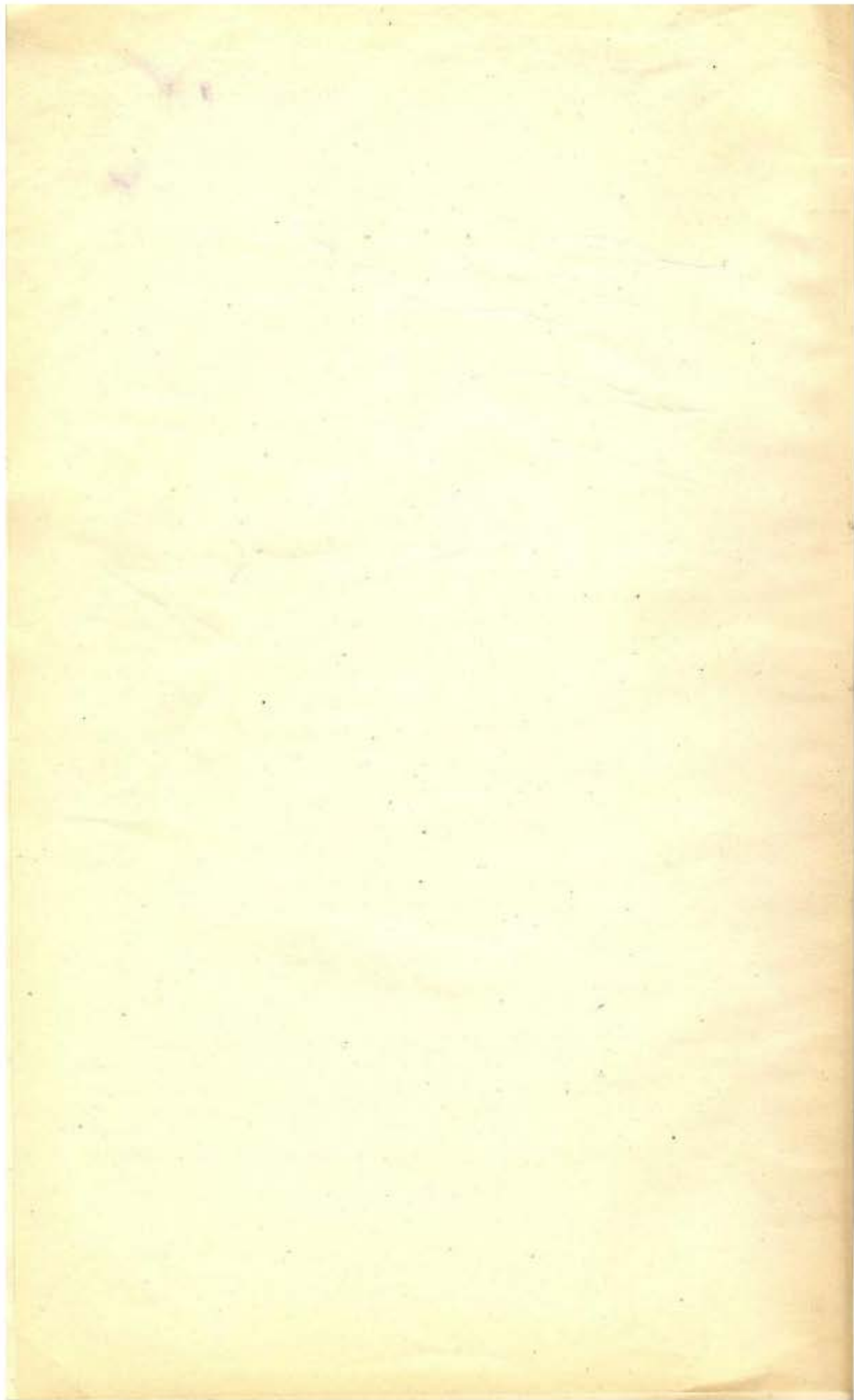

SPECIAL NOTE

Owing to the War ending, certain stores described in this Handbook have been withdrawn from service.

They have not, however, been deleted from this Edition because it is felt that their use during the War 1939-1945 should be on record. Also it would have meant reprinting, as the book was ready for the binders before the corrections could be made.

A list of stores under this category is appended, and it will be supplemented by "P" Series A.F.O. amendments as required.

Apparatus A.D.
 Bombardment, Cartridges and Charges.
 Cartridges, Aircraft, Catapult.
 Cartridges for Holman Projector.
 Charges, Bombardment.
 Cordite A.S.N.
 Fuze No. 125.
 Fuze No. 402.
 Fuze Time and Percussion, No. 93.
 Holman Projector.
 P.A.C.
 Projectiles—Chemical Shell.
 Projectiles—Paper Shot.
 Projectiles—Shrapnel Shell.
 Pyrotechnics—Projectiles Illuminating.
 Pyrotechnics—Rocket Illuminating.
 Q.F. Cartridges—Bombardment.
 Rocket Flare Illuminating 9 lbs. (Snowflake)
 and Shrapnel shell.
 Time and Percussion Fuzes.

CONTENTS

	<i>Page</i>
LIST OF PLATES	xvi
GLOSSARY	xix
INDEX	132
SCHEDULE AND ILLUSTRATIONS OF INSTRUMENTS AND KEYS	131

CHAPTER I—GENERAL REMARKS ON EXPLOSIVES

	<i>Para.</i>
Definition of Service Explosive	1
Combustion and Explosion	2
Detonation	3
Classification of Explosives for Service purposes	4
Stability and keeping properties	9
Initiation	11
Blast effect, fragmentation, danger zone	12

CHAPTER II—PROPELLANTS

Chief requirements of a Service propellant	15
Cordite	16
Main features. Sizes. Lotting	18
Full Flash propellants	21
Flashless and Non-blinding propellants	30
Definition of a Flashless Charge	31
Types, sizes and features	36
American propellants—Nitrocellulose powders	39

CHAPTER III—HIGH EXPLOSIVES

Chief requirements of Service High Explosives	55
Classification	56
Initiators	57
Fulminate of Mercury	58
Lead Azide	60
Cap Compositions	62
Intermediaries	65
Tetryl Composition Exploding (C.E.)	66
Picric Powder	68
T.N.T. Crystals	70
Shell and Bomb Fillings	71
Lyddite or Picric Acid	72
T.N.T.	74
T.N.T. Beeswax	76
Shellite	77
R.D.X.	79
P.E.T.N.	80
Amatol	81
Baratol	83
Table. Schedule of High Explosives	85

CHAPTER IV—GUNPOWDER AND PYROTECHNIC COMPOSITIONS

Gunpowder	90
Ingredients and properties	92
Service uses	93
Sulphurless Gunpowder	94

	<i>Para.</i>
Pyrotechnic Compositions	95
Illuminating compositions	97
Signal compositions... ..	98
Smoke compositions	99
Incendiary compositions	100

CHAPTER V—CHARGE WEIGHTS

Determination of Charge Weight	105
Nominal, adjusted and fixed Weights	106
Reduced Charges	109

CHAPTER VI—CARTRIDGES FOR B.L. GUNS

General Remarks	115
Cartridges, B. L.	117
Charge	118
Tinfoil	119
Silk Bag	120
Lifting Bands	121
Igniters	122
Igniter Covers	123
Cartridge, Drill, B.L.	127
Markings on Cartridges, B.L.	128
Types of Charge	129
Full	130
Reduced	131
Star Shell	132
Super	133
Bombardment	134
Special Gunnery School Charges	138
Table of Fractional and Reduced charges, Igniters, etc.	139
Cardboard Protecting Tubes	140
Containers... ..	141
Boxcloth Wrappers	142
Clarkson's Cases	143

CHAPTER VII—CARTRIDGES FOR Q.F. GUNS AND AIRCRAFT
CATAPULTS

General Remarks	150
Separate and Fixed Ammunition	151
Cartridge cases	153
Tinfoil	157
Felt wads	158
Lids	159
Safety Clips	165
Special Charges	168
Reduced	169
Star Shell	171
Bombardment	172
Special Gunnery School	181
Clearing Charge	182
Stampings on Base of Cases	186
Stencilling on Base of Cases	187
Markings on the Lids of Cases	188
Cartridges for Aircraft Catapults	189
Case	191
Cordite charge	192
Primer	193
Safety Clip	194
Method of assembling	195

CHAPTER VIII—TUBES, VENT

	<i>Para.</i>
General Remarks	205
.5-inch	209
.4-inch	215
1-inch	218
Drill Tubes	219
Marking of Tubes	220
Packing of Tubes... ..	221

CHAPTER IX—PRIMERS

General Remarks	223
Primers, Electric	224
Primers, Percussion	225
Primers, Electric and Percussion	227
Markings on Primers	228
Markings on Adapters	230

CHAPTER X—BLANK CARTRIDGES

General Remarks	235
B.L. Blank Cartridges	236
Q.F. Blank Cartridges	237
Q.F. Blank Cartridges " to be made up on board "	238
Q.F. Blank Cartridges.	
4.7-inch, 4-inch, 3-inch 20 cwt.	240
4-inch, Marks V-V**, XV, XVI and XVI*	241
3.7-inch Howitzer	242
12-pdr. 12-cwt.	243
6-pdr. and 3-pdr.	244
Markings on B.L. Blank Cartridges	245
Markings on Q.F. Blank Cartridges	246
Packing	247

CHAPTER XI—PROJECTILES

Section 1—General Remarks

Factors influencing design.	250
Travel down the bore	251
Flight in the air	252
Damaging the target	258

Section 2—H.E. Filling

Chief Requirements	259
Exploders.	259a
For Detonative impulses	260
For Igniferous impulses	261
Methods of filling.	262
T.N.T.—Poured	262a
T.N.T.—Block Filling	263
T.N.T.—Beeswax	264
Shellite. Lyddite	265
R.D.X./B.W.X.	266
R.D.X./T.N.T.	266

	Section 3—Special Features	<i>Para.</i>
Driving Bands		267
Double Driving Bands		270
Penetrative Caps		271
"K" and "A.K." devices		273
Base Adapters		279
	Section 4—Piercing Shell	
General Remarks		281
Armour-Piercing, Capped (A.P.C.)		282
Semi Armour-Piercing, Capped (S.A.P.C.)		284
Semi Armour-Piercing (S.A.P.)		285
Common Pointed, Capped (C.P.C.)		286
Common Pointed Ballistic, Capped (C.P.B.C.)		287
	Section 5—High Explosive (H.E.) Shell	
General Remarks		289
	Section 6—Other Projectiles	
Star Shell		291
Star Shell, 2-pdr.		296
Smoke Shell, B.E., with a Time Fuze		298
Smoke Shell with a D.A. Fuze		299A
Shrapnel Shell		300
Target Smoke Shell		302
Practice Projectiles		304
Target Ship Practice Projectile		305
Proof Projectiles or Shot		306
Paper Shot		306A
Drill Shell		307
Dummy Shell		309
	Section 7—Markings on Projectiles	
General		310
Stampings		312
Colouring and Stencilling		313
Colouring		314
Points and Caps		315
Bands round the body		316
Shell bases		317
Stencilling... ..		318
	Section 8—Tracers, Igniters, Tracers and Igniters	
Tracers, Shell.		322
No. 1, Mark VI		324
No. 13		325
No. 2, Mark V		326
No. 16		327
Nos. 8 and 9		328
Igniters, Shell.		329
No. 1		330
Tracer and Igniter Shell.		329
No. 7		332
No. 14		333
CHAPTER XII—SHELL FUZES AND GAINES		
	Section 1—General Remarks	
Types of Fuze		336
Classification—Detonating. Igniferous		337
Safety Arrangements		338
Markings on Fuzes		339
Dynamical factors governing design		340

	Section 2—Percussion Fuzes	<i>Para.</i>
Percussion, Direct-action	...	346
No. 45P	...	348
No. 44	...	353
No. 118	...	358
No. 230	...	359
No. 360	...	364
No. 241	...	365
No. 243	...	369
No. 246	...	370
No. 248	...	373
No. 251	...	374
No. 255	...	375
No. 259	...	378
Base, Percussion	...	379
Delay fitting	...	381
Hotchkiss, Mark IX	...	383
Medium. Nos. 500, 501 and 502	...	387
Large. Nos. 159, 346 and 480	...	391
	Section 3—Time Fuzes	
Time, Combustion	...	397
Fuze Powders	...	399
Tensioning and clamping	...	403
Fuze setting	...	408
Escape Holes	...	410
No. 125	...	411
No. 198	...	417
No. 400	...	424
Time, Mechanical	...	429
Setting	...	429 ^a
No. 206	...	435
No. 207	...	440
No. 211	...	441
No. 215	...	446
	Section 4—Time and Percussion Fuzes	
General	...	447
No. 93, Mark I	...	448
	Section 5—Drill Fuzes	
Drill, percussion, direct-action fuzes	...	454
Drill, time fuzes	...	455
Marking of drill fuzes	...	456
	Section 6—Gaines	
General	...	457
No. 10	...	458
No. 9	...	462
No. 11	...	463
	Section 7—Detonators for Fuzes and Gaines	
General	...	467
Disruptive Detonators	...	469
Igniferous Detonators	...	471
Filled "A" mixture	...	473
Filled "B" mixture and powder	...	474
	Section 8—Miscellaneous	
Failure and accidents with Fuzes	...	475
Firing through Muzzle Covers	...	477
Care of Fuzes	...	480
Metal Covers	...	481
Kit Plasters	...	482

Section 9—Fuzing and Unfuzing Shell		<i>Paar.</i>
General		484
Instructions to fuze		485
Instructions to unfuze		486
Time Mechanical Fuzes and Fuze No. 230		487
To fuze with No. 211		488
To fuze with No. 230 over Gaine No. 9 or 10		489
To remove No. 230 and Gaine No. 9 or 10		490
Fuzes in 14-inch, 15-inch and 16-inch, H.E. Shell.		491
To remove Time Combustion fuze in 14-inch and 16-inch H.E. shell and fuze with Fuze No. 118		492
To remove Fuze No. 118 in 14-inch and 16-inch H.E. shell and fuze with a Time Combustion fuze		493
To remove a Time Combustion fuze in 15-inch H.E. B.N.F. shell and fuze with Fuze No. 360		494
To remove Fuze No. 360 in 15-inch H.E. B.N.F. shell and fuze with Time Combustion fuze		495
H.E shell with a Universal Cavity 4-inch to 16-inch		495A
Table of Fuzes and Gains		496

CHAPTER XIII—SMALL ARMS AMMUNITION

Section 1—General Remarks		
Cartridge Case		506
Charge		508
Bullet		509
Markings and means of identification		511
Types of Cartridge.		
Ball		516
Armour-Piercing (A.P.)		517
Semi-Armour-Piercing (S.A.P.)		518
Tracer		519
S.A.P. Tracer		521
Incendiary		522
Proof		523
Blank... ..		524
Drill		525
Dummy		526
Observing		527
Rifle Grenade Ballistite		528
Rifle Grenade Cordite		529

Section 2—Revolver and Pistol Ammunition		
General		530
Pistol, Revolver, No. 1, 0.455-inch		532
Pistol, Revolver, No. 2, 0.380-inch		536
Pistol, 0.455-inch		537

Section 3—American Small Arms Ammunition		
General Remarks		539
Table of American Cartridges, Calibres and Colour Markings		541

CHAPTER XIV—S.A.A. (continued) AIMING RIFLE AND MINIATURE RIFLE CARTRIDGES

Aiming Rifle Cartridges		550
1-inch Electric, Mark II		551
1-inch Percussion, Mark III		552
Miniature Rifle Cartridges.		
0.22-inch Cartridge		553

CHAPTER XV—S.A.A. (continued) 20 M.M. CARTRIDGES

	<i>Para.</i>
General Remarks	560
Section 1—Oerlikon	
British Oerlikon	561
Fuzes Nos. 254 and 258	561
Charge	561
Shell filling	561
Markings and means of identification	562
Types of Ammunition	562
Projectile, Practice	563
Projectile, Practice Tracer	564
Shell, H.E., Incendiary (H.E./I.)	565
Shell, H.E., Incendiary Tracer (H.E./I./T.)	566
Shell, Semi-Armour-Piercing/H.E./I. (S.A.P./H.E./I.)	567
Shell, H.E. (H.E.)	568
Shell, H.E., Tracer (H.E./T.)	569
Cartridge, Drill, Marks I and II	570
Clearing Charge	572
American Oerlikon	573
Types of Ammunition, fillings and colour markings	574
Section 2—Hispano	
General Remarks	577
Markings and means of identification	578
Types of Ammunition	579

CHAPTER XVI—ROCKET-PROJECTED DEVICES

	<i>Para.</i>
Section 1—Projectiles	
Rockets, "U"	590
Rockets, "U," 2-inch	592
Tail, propelling	593
Tail Fins	594
Shell	595
Fuze No. 720	596
Action	597
Section 2—Illuminants	
2-inch Rocket Flare	598
Main component parts and order of assembling... ..	598
Tail, propelling	600
Fins	600
Flare Head	601
Action	602
Rocket, Illuminating, 9-lbs. (Snowflake)	603
Action	604
Section 3—Apparatus, Air Defence (A.A.D.)	
Type D (P.A.C.), Mark IIN	605
Rocket	606
Main Container	607
Main Cable	608
Lower Parachute assembly	609
Action	610
Type J, Mark I	611
Tail, propelling	612
Head Canister and Thermal Fuze... ..	613
Main Container	615
Action	616

	<i>Para.</i>
Mark IA	617
Mark II	618
Type L, Mark I	619
Tail, propelling	620
Top Conical Canister	622
Lower Canister	623
Action	624
Mark II	625

CHAPTER XVII—GRENADES

Hand Grenades	630
Grenade No. 36M	630
Action	633
Grenade No. 69, Mark I	636
Action	638
Marking	639
Rifle Grenade	641
Discharger No. 1, Mark I	641
Cartridge, S.A., 0.303-inch Ballistite, H, Mark IZ	642
Action	643
Packing	645

CHAPTER XVIII—HOLMAN PROJECTORS. B.L. 4-INCH MORTARS

Projectile, Illuminating, No. 1	650
Action	652
Projectile, Illuminating, No. 2	653
Holman Cartridge	654
Bomb, 10-lb., Underwater No. 1, Mark I, with gas check	655
Action	656
Smoke Float, B.L., 4-inch Mortar, Marks II or III	657
Action	658
Bomb, B.L., H.E., 4-inch Mortar, 10 lb., Mark I	659
Action	660

CHAPTER XIX—PYROTECHNICS

Classification	670
Signalling and Navigation.	
Rocket, Signal, 1-lb., Service	671
Rocket, Signal, 1-lb., red, green	674
Cartridges, Signal, 1-inch and 1½-inch	675
Flare Signal	677
Flame, Float, delay, Mark I	679
Illumination.	
Rocket, 1-lb., Magnesium Star	681
Recognition and identification.	
Submarine Smoke Candles, General remarks	685
Candle Smoke, white, Mark I	687
Targets for Close Range A.A. Weapons.	
Rocket, Target, practice, 1-lb.	689
Initiators.	
Portfire	692
Quick Match	693
Slow Match	694
Light, Short	695
Friction Tube	697

Insert:—

Recognition and Identification Signals	685
Flare Identification	688

Fireworks' Boxes. General remarks	Para.
Night Signal Box	699
Sea Boat Box	701
Boat's Magazines	702
Gig's Magazine	703
Steam Boats	703b
	704

CHAPTER XX—LINE CARRYING ROCKETS AND LINE THROWING GUNS

Line carrying Rockets	710
Rocket, Line carrying, Schermuly 2-lb.	710
Instructions for use	711
Rocket, Line carrying, Schermuly 1-lb.	712
Line-throwing Guns	713
Line-thrower, Shoulder Coston	714
Rifle, M.L.E. (0.303-inch long)	715

CHAPTER XXI—AIRCRAFT BOMBS AND THEIR COMPONENTS

Factors influencing design	720
Exploder system	721
Fuzes for H.E. Bombs	722
Pistols for H.E. Bombs	723
Tail Pistols	724
Nose Pistols	725
Safety Arrangements of fuzes and pistols	726
Detonators for H.E. Bombs	728
Detonator—Burster	729
Bomb Tails	730
Types of Bombs.	
S.A.P. and A.P.	732
General Purpose (G.P.)	733
Medium Capacity (M.C.)	734
Anti-Submarine (A.S.)	735
Anti-Personnel	736
Incendiary	737
Practice	738
Drill	739
Markings	740*

CHAPTER XXII—AMMUNITION PACKAGES

Section 1—General Remarks

Section 2—Packages stowed on board with their ammunition

Cylindrical Cases	750
C.E.	751
M.	754
C.F.	757
Rectangular Cases	760
R.M.	761
R.N.	764
R.J. and R.H.	767
T., W., S., R., and C.	769
List of Keys	772
Boxes for Q.F. Ammunition	773
Cartridge Boxes—	
C. 23, Mark II	774
C. 185	775
	776

LIST OF PLATES

	<i>Paragraph Reference in the text</i>
Chapter VI—Cartridges for B.L. Guns.	
• Plate 1. Cartridge, B.L., 14-inch, $\frac{1}{4}$ charge	117
„ 2. Bombardment charge for B.L. 6-inch Mark XII Gun	134
„ 34. Clarkson's Cases, Containers and Boxcloth Wrappers	141
Chapter VII—Cartridges for Q.F. Guns and Aircraft Catapults.	
Plate 3. Cartridge, Q.F. 4.7-inch, Separate Ammunition, filled N./F.Q./S.	151
Cartridge, Q.F. 4.7-inch, Separate Ammunition, filled N.H.	156
Cartridge, Q.F. 4.5-inch, Fixed Ammunition, filled N./F.Q./S.	152
Cartridge, Q.F. 4.5-inch, Fixed Ammunition, filled N.H.	156
Safety Clips, No. 12, Mark III, and No. 25, Mark V	166
„ 2. Bombardment Cartridge, Q.F. 4.7-inch, Marks IX*, IX**, XII and XII* Guns	173
„ 4. Cartridge, Catapult, Aircraft, 8-inch	189
Chapter VIII—Tubes Vent	
Plate 5. Electric, 0.5-inch, Mark X	210
Electric S, 0.5-inch, Mark VIII	212
Percussion, 0.5-inch, Mark VI	213
Electric, 1-inch, Mark IV	218
Chapter IX—Primers.	
Plate 6. Electric No. 13, Marks I* and II	224
Percussion No. 27, Mark I	225
Percussion No. 9, Mark III	225
Electric and Percussion No. 14, Mark V	227
Chapter X—Blank Cartridges.	
Plate 7. Q.F. 4.7-inch, Marks IX, IX*, XII, XII* Guns	240
Q.F. 4-inch, Marks V, V**, XV, XVI and XVI* Guns Reduced Mark II	241
Q.F. 3.7-inch Howitzer, Mark II	242
Q.F. 12-pdr. 12 cwt.	243
Q.F. 3-pdr.	244
Chapter XI—Projectiles.	
Plate 8. Shell B.L. Armour Piercing with cap, 15-inch	282
Shell B.L. Semi-Armour Piercing with cap, 8-inch gun "K" Mark IB, N.T.	284
„ 9. Shell B.L. Common Pointed with Ballistic cap, 6-inch gun, Mark XXXV, B.Q.	287
Shell Q.F. S.A.P. 5.25-inch, A.K., Mark II, C.T.	285
Shell Q.F. S.A.P. 4.7-inch, Heavy, Mark VA	„
„ 10. Shell B.L. High Explosive, 8-inch... ..	289
Shell B.L. High Explosive, 6-inch gun Mark XII, A.Q., N.T.	„
Shell B.L. or Q.F. High Explosive, 4.7-inch, Heavy, Mark VII. A	„
„ 11. Shell, Q.F. High Explosive, 2-pdr. H.V. (2 figures)	„
Shell, Q.F. High Explosive, 40 mm.	„
Projectile Practice Tracer, Q.F., 40 mm.	„
„ 12. Shell, Q.F. Star, 4-inch, F.A., 35 lb., Mark IB	291
Shell, Q.F. Smoke, B.E., 4.7-inch, Heavy, Mark IA	298
Shell, Q.F. Shrapnel, 12-pdr., Mark XIII	300
„ 13. Colouring of Projectiles	314
„ 14. Stencilling on Shell	318
„ 15. Tracer, Shell No. 1, Mark VI. External	324
„ „ No. 2, Mark V. Internal	326
„ „ No. 8, Mark II	328
Igniter, Shell No. 1, Mark I	330
Tracer and Igniter Shell, No. 7 Mark IV. Internal	332

	<i>Paragraph Reference in the text</i>
Chapter XII—Shell Fuzes and Gains.	
<i>Plate 16.</i> Percussion, D.A.L., No. 45P Mark X	348
" D.A. No. 44 Mark X with cap	353
" " No. 118 Mark II... ..	358
" " No. 230 Mark V	359
" 17. Percussion, D.A. No. 241 Mark I	365
" " No. 246 Mark I	370
" " No. 255 Mark I	375
Time and Percussion, No. 93 Mark I	448
" 18. Percussion, Base, Hotchkiss Mark IX	383
" " Medium, No. 501 Mark I	387
" " Large, No. 480 Mark II	391
" 19. Time, Combustion, No. 125 Mark I	411
" " No. 198 Mark II	417
" " No. 402 Mark I	425
Gain, No. 10 Mark I	458
" No. 11 Mark II	463
" 20. Time, Mechanical, No. 211	441
Chapter XIII—Small Arms Ammunition.	
<i>Plate 21.</i> Rifle and Machine-gun Cartridges	515
" 22. Revolver, Pistol and Machine Carbine Ammunition	530
Chapter XIV—1-Inch Aiming Rifle.	
<i>Plate 22.</i> Cartridge, Aiming Rifle, 1-inch	550
Percussion Primer	551
Electric Primer	552
Chapter XV—20 mm. Small Arms Ammunition.	
<i>Plate 23.</i> 20 mm. Oerlikon Ammunition	560
Colour markings (British)	562a
" " (American)	576
Chapter XVI—Rocket Projected Devices.	
<i>Plate 24.</i> Rocket "U," 2-inch	592
2-inch Rocket Flare	598
" 25. Apparatus A.D., Type D (P.A.C.)	605
" " Type J	611
" 26. " " Type L Mark II	625
Chapter XVII—Grenades.	
<i>Plate 27.</i> Grenade No. 36M (Mills bomb) Mark I, with Gas Check fitted	630
" No. 69, Mark I	636
Chapter XVIII—Holman Projectors. 4-Inch Mortars.	
<i>Plate 28.</i> Projectile, Illuminating, No. 2, Mark I	653
Bomb, 10 lb., Underwater, No. 1, Mark I, with gas check	655
" 29. Smoke, Float, B.L., 4-inch Mortar, Marks II or III	657
Bomb, B.L., H.E., 4-inch Mortar, 10 lb., Mark I	659
Chapter XIX—Pyrotechnics.	
<i>Plate 30.</i> Rocket, Signal, 1 lb., Service	671
Cartridge, Signal, Red 1-inch Mark XIV T	676
" " Green, 1-inch Mark XI T	675
" " Red 1½-inch Mark V T	675
Flare, Signal, Mark II	677
<i>Plate 31.</i> Rocket, Target, Practice, 1 lb.	689
Candle, Smoke, White, Mark I	687
Flame, Float, Delay, Mark I N	679

	<i>Paragraph Reference in the text</i>
Chapter XX—Line Carrying Rockets.	
<i>Plate 31.</i> Rocket, Line-carrying Schermuly 2-lb. Mark I	710
Chapter XXI—Aircraft Bombs and Components.	
<i>Plate 32.</i> Bomb, H.E., M.C., 500 lb., Mark II	734
" " S.A.P., 250 lb., Mark V	732
Bomb Practice, 10 lb., Mark I	738
" 33. Fuze, Percussion, Aircraft Bomb, tail, No. 30 Mark III	722
Pistol, Bomb tail, No. 30, Mark III	724
" " D.A., No. 27 Mark I, 1* and II	"
" " " No. 44 Mark I	"
Chapter XXII—Ammunition Packages.	
<i>Plate 34.</i> Cases, Powder, Cylindrical, C.E., M. and C.F., Mark II	750
Cases, Powder, Rectangular, R.M., R.N., R.H. and W.	760
" 35. Cartridge Boxes, C.23, Mark II, and C.185	775
Ammunition Boxes, C.163, C.190, C.87	780
Cases, Powder, M.L., C.118, C.119 and C.121	783
Boxes, A.S.A., H.3, H.4, H.24 and H.33	785
Transport Packages, C.222, C.217 and C.227	801
Labels	<i>facing page</i> 117
Chapter XXIV—Magazines and Shell Rooms.	
<i>Plate 36.</i> Flooding and Spraying Arrangements—	
(1) 6-inch Magazine and Handing Room, H.M.S. "Newcastle"	850 and 854
(2) 6-inch Magazine and Shell Room, "Fiji" Class	851 and 854
" 37. Flooding Arrangements, 14-inch Magazine and Shell Room, "King George V" Class	850
Spraying Arrangements, 14-inch Magazine and Handing Room, "King George V" Class	854
" 38. Magazine Stowage Arrangements, 14-inch Magazine, "King George V" Class. Pom-Pom Magazine	856 and 857
" 39. Magazine Stowage Arrangements, 6-inch Magazine, "Southampton" Class. Bottle Rack Stowage O.F. 4-inch Magazine "Algerine" Class	856
" 40. Magazine Ventilation—Air cooling and drying, diagrammatic arrangement ...	860

GLOSSARY

The definitions given are intended to apply to the terms in the sense in which they are used in this book.

Annulus: *In small arms ammunition, the varnished ring between the percussion cap and the base of the cartridge.*

Blast: *The outward pressure of the air caused by its displacement at the point of the explosion or detonation.*

Cannelure: *A groove, especially a circular groove formed round a bullet or projectile near its base.*

Capacity: *When used in relation to shell or bombs, the amount of explosive filling stated as a percentage of the total weight of the shell or bomb.*

Centrifugal force: *The radial force acting on a body travelling in a curve, owing to the tendency of the body to continue travelling in a straight line.*

Choking: *A method of closing the neck of a bag containing explosive in powder form by drawing it together into several pleats and then tying it round with silk thread.*

Coning: *A method of securing a projectile in its case consisting in pressing the mouth of the case into a cannelure on the projectile.*

Crimping: *A method of closing the mouth of a cartridge case with a series of small folds, e.g., as a means of retaining the charge in unbulleted blank cartridges.*

Danger Zone: *The space round the point where an explosion or detonation occurs within which damage may be caused. It may be divided into two distinct areas:—*

(i) *The Blast Zone—in which persons or material may be damaged by the expansion of gases of that explosion or detonation.*

(ii) *The Fragment Zone—in which persons or material may be damaged by fragments produced by an explosion or detonation. The fragments may consist of portions of the walls of the shell or other container or may be formed by material set in motion by the explosion.*

Drift: *The deviation of a projectile to the right from the plane of departure due to its clockwise rotation.*

Endothermic: *(of a chemical compound). Absorbing heat on its formation; lead azide is an example of such a compound.*

Erosion: *The wear mechanically produced on metals with which they come into contact by:—*

(i) *The mechanical friction of the solid products of an explosion.*

(ii) *The scrubbing action of the hot gases.*

The alternate heating and cooling, e.g., of the bore, by causing surface disintegration accelerates the erosive effect.

Fragmentation: *The breaking up of the container of an explosive; the more violent the explosion, the smaller and more numerous are the fragments produced.*

Hygroscopic: *Tending to absorb moisture from the air; ammonium nitrate is an example of such a substance.*

Indenting: *Process of pressing the metal of a cartridge case into a cannelure on shell or bullet at several separate points on the circumference.*

Inertia: *The property by which matter continues in a state of rest or uniform motion in a straight line, except in so far as the state is changed by external force.*

Muzzle Velocity: *The velocity of a projectile relative to the mounting at the moment it leaves the muzzle; sometimes called "Initial velocity."*

Necking: *The operation of reducing the diameter of the mouth of a cartridge case from chamber diameter to projectile diameter, resulting in the formation of the conventional "bottle-shaped" cartridge. The operation may also be used to fix a bullet in its case, with or without an additional operation such as indenting.*

O.F.M.: *Obsolete for future manufacture.*

Penetration: *Holing of armour caused by shell burst on or near its surface.*

Perforation: *Passage of shell through armour in a fit condition to burst on the far side.*

- Remaining Velocity:** *The velocity of a projectile, relative to the gun from which it was fired, at any point of the trajectory.*
- Ringing:** *A method of securing percussion caps in small arms cartridges; the metal of the lip of the cap chamber is forced inwards over the base of the cap.*
- Stabbing:** *A similar process to "ringing," but small portions only of the lip of the cap chamber are pressed in to retain the cap.*
- Stemming:** *A process used to press C.E. into the various channels of some fuzes. It is done by hand with a wooden drift. Rochets, lights, etc., are driven or stemmed with the rochet composition in a similar manner, but a mallet is used with the drift.*
- Striking Velocity:** *The velocity of a projectile, relative to the target, at the point of impact.*
- Sweating:** *The joining of two metal surfaces previously coated with solder by placing them in contact and applying heat until the solder runs.*
- Time of flight:** *The time a projectile takes to reach the point of impact, reckoned from the moment it leaves the muzzle of the gun.*
- Trajectory:** *The path described by the centre of gravity of a projectile in flight.*
- Vertex:** *The highest point of the trajectory; also known as the "culminating point."*

CHAPTER I

GENERAL REMARKS ON EXPLOSIVES

DEFINITION OF SERVICE EXPLOSIVE

1. An explosive is a substance or a mixture of substances in which, in suitable conditions, it is possible to initiate chemical change which will proceed with great rapidity throughout the mass and convert it into large quantities of heat and gases. It is characteristic that this chemical change propagates itself through the mass of explosive from the place of initiation without further supply of external energy or material. The energy liberated by the small layer of explosive immediately subjected to the initiating impulse is sufficient to cause the explosion of the next layer; the energy from this layer causes the explosion of the next, and so on.

COMBUSTION AND EXPLOSION

2. The phenomenon of combustion is familiar, and it is well known that different substances burn at different rates. Ordinary combustion is a process by which substances combine with the oxygen of the air, and therefore the rate of combustion is limited by the amount of oxygen present and the rate at which it can be supplied. If, however, the oxygen required be closely associated with the combustible in some other form (as for instance in gunpowder, where the charcoal and sulphur are the combustibles and the oxygen is supplied in the potassium nitrate) combustion can proceed independently of the atmospheric oxygen and within the mass of the mixture itself. This causes a very much more rapid rate of combustion, which can be still further increased by confinement in some vessel, producing what is known as explosion.

Explosion is a combustion whose velocity varies from about a foot a second up to about 1,000 feet a second. This velocity is constant for a given substance, and under constant conditions of pressure, temperature, etc.

DETONATION

3. The explanation of the phenomenon known as detonation is outside the scope of this book, but it may be said to be an action closely allied to explosion though far more rapid in character. It proceeds through the bulk of the explosive in the form of a wave known as the detonation wave. The detonation wave in service explosives varies from about 10,000 to 30,000 feet per second, according to the chemical nature, physical condition and degree of confinement of the explosive. Detonation is characterised by its powerful shattering effect, the result of the extremely high local pressures which the almost instantaneous action produces.

CLASSIFICATION

4. The rates of combustion obtained with different explosives vary according to the manner in which they are contained and the method of their initiation; a rough classification has been adopted in which explosives with rates of combustion above approximately 1,000 feet per second are, in general, classified as High Explosives and the remainder are Explosives or Low Explosives.

5. For Service purposes explosives are placed in the following categories:—

- (1) **PROPELLANTS or Low Explosives.** These are used for the propulsion of projectiles from guns and Small Arms.
 - (2) **HIGH EXPLOSIVES.** These are used for disruptive purposes.
 - (3) **EXPLOSIVE COMPOSITIONS.** These include Gunpowder, and pyrotechnic and other compositions which cannot be detonated.
- Note.*—In certain conditions (1) can be used in the place of (2).

6. The changes in velocity of combustion during the progress of explosion of a solid explosive rising to the maximum velocity known as detonation may be divided into three periods:—

- (1) *Ignition.*—During this the velocity of decomposition increases from zero to that of ignition; ignition is completed when the heat evolved by decomposition exceeds the heat lost by radiation and conduction.
- (2) *Explosion.*—The explosion then proceeds at a uniform velocity, provided the pressure remains constant. The pressure rise may be sufficiently rapid to cause detonation.
- (3) *Detonation.*—This proceeds at a maximum velocity of several thousand feet a second, which is almost unaffected by external pressure.

7. Propellants are ignited and explode at a velocity depending on the surrounding pressure, which should not rise so rapidly as to cause detonation.

8. High explosives of the Initiator type, when ignited in conditions of confinement, rapidly reach the detonation stage.

High explosives of the Intermediary and Shell filling types are detonated by picking up a detonating wave from an adjacent detonating explosive.

CH. I.

STABILITY AND KEEPING PROPERTIES

9. One of the principal considerations in the choice of an explosive for a particular purpose is its stability or keeping properties in conditions likely to be met with in service. Explosives vary widely in their stability in storage, especially in warm climates. Deterioration may be due to:—

- (1) *Chemical Instability* (i.e., a natural tendency to decompose slowly, frequently accelerated by impurities or by the products of decomposition). With the majority of Service explosives the effect of chemical deterioration is a loss of efficiency. With propellants, decomposition may proceed so rapidly as to lead eventually to the formation of sufficient heat to cause spontaneous ignition.
- or (2) *A Change in the Physical Condition* brought about by high temperatures, access of moisture, etc. Physical changes include the melting, freezing or crystalline change of the explosive or any of its components, the absorption of water from damp atmospheres and the loss of volatile constituents.

10. Containers for explosives are made of, or coated with, materials which do not interact with the explosive or produce deterioration or dangerous substances.

INITIATION

11. The particular method of initiation is decided by the nature of the explosive and the circumstances in which it is used.

Explosives vary considerably in sensitiveness, that is to say, in the ease with which they can be initiated. Fulminate of mercury is detonated by very slight friction, but T.N.T. can withstand blows of some violence.

In practice, sensitive high explosives are detonated either by flash or an electrically-heated wire, by percussion, friction or by pricking with a needle.

Less sensitive high explosives are detonated by detonating a small charge of a more sensitive explosive in close contact with them. For example, in shell filled with High Explosive a very small charge of an Initiator (e.g., Fulminate of Mercury or Lead Azide) initiated by flash or percussion is used to detonate a larger charge known as an Intermediary (e.g., Composition Exploding) whose detonation in turn detonates the main charge (e.g., T.N.T.).

Explosive compositions and propellants are usually initiated by flame from an igniferous mixture.

Poor initiation or igniferous initiation of a high explosive will lead only to explosion. Poor initiation may be caused by a lack of close contact. On the other hand, many high explosives if ignited, and if in sufficient bulk or confinement, may burn fiercely enough to proceed to detonation.

12-14.

CHAPTER II

PROPELLANTS

CHIEF REQUIREMENTS

15. The chief requirements of a propellant are :—

- (1) *To have a Regular and Readily Controllable Rate of Burning (i.e., regular ballistics).*—A regular rate of burning and a steady development of pressure are obtained by using a colloidal (i.e., gelatinized) explosive of a uniform composition which can burn only from the exposed surfaces, layer by layer. The amount of surface exposed governs the rate of burning. The size (i.e., the diameter) of the cord determines the rate of burning as, for a given charge weight, a number of small cords offers more surface than a few large ones. If required, the surface area can be further increased by making the propellant in tubular, multi-tubular or slotted tubular form, or in discs or flakes. In this way propellants of identical compositions can be used in weapons varying from a revolver to a big gun.
- (2) *To be Smokeless and leave no Residue.*—Smokelessness is important from a tactical standpoint. Residue has a practical significance as hot smouldering fragments remaining in the bore are dangerous; solid residue fouls the bore and increases erosion.
- (3) *To be free from Muzzle Flash and Back Flash.*—In addition to disclosing the position of the ship, muzzle flash is apt to dazzle or blind the control and bridge personnel or the gunlayer. Back flash is dangerous to personnel and may ignite cartridges or other inflammable material near the breech. Both muzzle flash and back flash are due to the formation of incompletely burnt gases at high temperatures. These gases ignite at the muzzle when coming into contact with the outside air after the projectile has left the gun and also on admixture with air when the breech is opened.
- (4) *Not to cause Erosion of the Bore.*—Erosion is due to the washing action of the hot gases, and is caused partly by their high velocity, but mainly by their high temperatures. The rapid heating and cooling to which the bore of a gun is subjected further tends to disintegrate the surface metal. The use of a propellant with a low heat value is therefore advantageous and leads to a reduction in wear.
- (5) *To be easy to Ignite.*—Most propellants are relatively difficult to ignite, and (with certain exceptions) gunpowder igniters are used.
- (6) *To be Stable in Storage and Transport.*—Propellants differ from most other explosives in that they undergo a continuous though slow process of decomposition. Direct sunlight, heat and damp accelerate the rate of decomposition. The condition of propellants in storage is ascertained by periodical tests. Decomposition is accompanied by an evolution of heat and the formation of free acids; if the former is not dissipated and the latter are not neutralised, decomposition is accelerated and may eventually become so rapid as to cause spontaneous ignition. Cool, dry storage and the addition of stabilisers to neutralise the free acids prolong the "life" of a propellant.
- (7) *To be unaffected by Moisture and Temperature.*—The general effect of moisture, if absorbed by a propellant, is to cause irregular ballistics. In addition, damp tends to promote chemical deterioration leading to instability. Exposure for short periods to extreme temperatures may lead to physical changes in the propellant, but these are usually only temporary.
- (8) *Not to be unduly sensitive to Impact or Friction.*
- (9) *Not to require unduly bulky charges.*
- (10) *Not to give off poisonous or irritating fumes.*

CORDITE

16. The first English smokeless "powder" was called Cordite, because the material was manufactured in the form of cords or sticks. It consists essentially of a colloidal mixture of nitrocellulose and nitroglycerine with a stabiliser to check deterioration. Other substances may also be incorporated to reduce or eliminate "flash" on firing.

The term now embraces materials of various compositions and forms, and the physical form of the different types is identified by appropriate letters :—

No letter	= Cord.	
T	= Tubular.	
M	= Multi-tubular.	
S	= Slotted tube.	
R	= Ribbon.	
D	= Drilled	}
G	= Grooved	
X	= Cruciform	

CH. II.

Some cordites produce a large flash on firing, and to overcome this disadvantage flashless and non-blinding cordites have been introduced.

17. This development has occasioned the grouping of cordites into :—

- (1) *Full flash.*
- (2) *Flashless and non-blinding.*

Main features of cordite.

18. *Burning.*—It is slow burning. The initial pressures are comparatively low and pressure on the projectile in the bore is well sustained.

Smoke.—The products of explosion of cordite are entirely gaseous, but a certain amount of yellow smoke is produced outside the barrel and some smoke comes from the gunpowder igniter.

Flash.—On firing, Full Flash cordite produces a large flash by reason of the high proportion of incompletely burnt gases (hydrogen and carbon monoxide) which ignite on coming into contact with the outside air.

Erosion.—The calorific value of the propellant has a considerable effect on the rate of erosion. Propellants of the flashless or non-blinding types, owing to their low heat values, are considerably superior to Cordite S.C. as regards wear effect.

Ignition.—Cordite is difficult to ignite. Most B.L. charges are fitted with gunpowder igniters to reinforce the flash from the tube. The smaller the diameter of the sticks the more easily they will ignite.

Storage.—Cordite is not a thoroughly stable substance. From the day it is made a slow but continuous decomposition goes on, producing acids which, if not rendered innocuous, accelerate the rate of decomposition. Stabilisers such as mineral jelly or carbamate, are added to neutralise these acids. The higher the temperature of storage, the more rapidly cordite deteriorates. The life of a "Lot" of propellant in the Naval Service is assessed for storage at temperatures not exceeding 90° F. Storing at higher temperatures involves a reduction of life. Exposure to low temperatures is undesirable, as this may result in exudation of nitro-glycerine. For these reasons all cordite except that in Small Arms Ammunition is periodically inspected and tested.

Sizes of cordite.

19. In general, the size of cordite is expressed in thousandths of an inch, and the figures follow the symbols denoting composition and shape.

Cord.—The size given is the diameter of the dry cords.

Tubular.—The figures give the external and internal diameters of the tube as it leaves the die. Thus H.S.C./T. 124-058 indicates that the tubes, when pressed, have an external diameter of 0.124-inches and an internal diameter of 0.058-inches. (Annulus = 0.033-inches.)

Multitubular.—The figures give the "mean web thickness" in inches. "Web thickness" is defined as the minimum distance between any two boundary surfaces.

Ribbon.—The figures give respectively the thickness and the width, e.g., 014 × 048 indicates a thickness of 0.014-inches and a width of 0.048-inches.

Scroll.—The figure gives the thickness, e.g., S.S.C.008 indicates a thickness of 0.008-inches.

Lotting of cordite.

20. A "Lot" of cordite is defined as "an arbitrary quantity of cordite of any one size, of the same composition and made in the same factory during a limited period of time."

Each lot is given a "Lot Number" when bonded for acceptance. The Lot Number consists of two parts, a letter or group of letters and the numerals. The letters are symbols of the particular maker.

FULL FLASH PROPELLANTS.**Cordite S.C. (Solventless Carbamate).**

21. Cordite S.C. is a horny substance of semi-transparent nature varying in colour from light to dark brown.

Solventless refers to the method of manufacture. Carbamate is the stabiliser.

Cordite S.C. is easy to handle and is not affected immediately by water or moisture. It burns with regularity, and is much more stable chemically than the older types of cordite, but, nevertheless, is subject to a gradual deterioration.

New Cordite S.C. is light in colour, but as the carbamate is used up the cordite develops a darker colour which is an indicator of its remaining life. Deterioration is very slow in good conditions of storage; it is more rapid in conditions of high storage temperature, direct sunlight or contamination. In good conditions Cordite S.C. has very little smell. It is poisonous owing to its nitro-glycerine content.

Cordite S.S.C. (Scroll Solventless Carbamate).

22. Scroll cordite is in the form of a pleated or corrugated sheet, charges are formed by rolling up a corrugated sheet with a plain sheet to space the corrugations. This cordite was developed as an alternative to H.S.C./T. It is used in Bombardment charges. C.S.S.C. (Cooler S.S.C.) has been developed to give a greater degree of flashlessness than S.S.C.

Cordite S.C./T. (Solventless Carbamite Tubular).

23. Cordite S.C./T. is made from fragmentary lots of old cordite S.C. pressed into tubular form. It was introduced for ballistic purposes and is used in large sizes for catapult charges.

Cordite S.U. (Solventless Carbamite Rocket).

24. Cordite S.U. (formerly S.C.R.K.) is a large tubular cordite similar to S.C./T. It is used as a charge for Rockets U.

Cordite H.S.C./T. (Hotter Solventless Carbamite Tubular).

25. Cordite H.S.C./T. has a greater nitro-glycerine content than Cordite S.C., and thus a higher calorific value; it is also more rigid. It is used for small calibre guns, 6-pdr. and below.

Cordites M.D. and M.D.T.

26. Cordite M.D. was developed owing to the excessive erosion caused to the bore of the gun by Cordite Mark I. It had the same ingredients as Mark I, but the proportions were "modified" (hence M.D.) to produce a cooler propellant. Cordite M.D. is now obsolescent.

Cordite M.D.T. is Cordite M.D. pressed in tubular form to increase the burning surface. It is used in Small Arms ammunition.

Cordites M.C. and M.C.T.

27. Cordite M.C. has the same composition as Cordite M.D., except that the stabiliser is cracked mineral jelly to improve the stability. Mineral jelly is less efficient than carbamite, and the safe life of Cordite M.C. is therefore less than that of Cordite S.C. Cordite M.C.T. is used for small calibre guns. These types of cordite are also obsolescent.

Cordite W.

28. Cordite W is a Land Service propellant and is similar to Cordite M.D. (or M.C.) with carbamite replacing mineral jelly.

Cordite W.M.

29. This is also a Land Service propellant and is similar to Cordite M.D. with carbamite partially replacing mineral jelly.

FLASHLESS AND NON-BLINDING PROPELLANTS.

30. Flashless propellants were originally introduced for Star Shell, but their use has been considerably extended. They are now used for full charges for guns up to B.L. 6-inch calibre. Investigations are in hand for flashless full charges for guns above 6-inch calibre.

Definition of a Flashless charge.

31. A flashless charge is defined as "one which is unlikely to attract the attention of the naked eye under normal atmospheric conditions at ranges of 3,000 to 4,000 yards." This applies to observation at night.

32. In certain guns full flashlessness has not been achieved up to date, but it has been found possible to suppress the flash to such an extent that it does not blind the Bridge and Control personnel. These charges are known as "Non-blinding."

33. *The advantages of flashless propellants over Full Flash propellants are:—*

- (i) Bridge and Control personnel are not blinded by flashes of their own guns.
- (ii) The position of the firing ship is not revealed by gun flashes.
- (iii) There is less wear on the gun.

34. *The disadvantages are:—*

- (i) They produce more smoke.
- (ii) They produce a greater concentration of toxic products and other gases which though non-toxic are very irritating to the nose and eyes.
- (iii) The charges are heavier and larger for the same ballistics; this may preclude their use in existing B.L. guns above 6-inch calibre owing to the limitations of the gun chambers, ammunition hoists, etc.

35. Flashless cordites are denoted by the generic letter N (Nolite). Other letters are suffixed to indicate the special characteristics of the propellant.

36. The types of this group in supply are:—

Cordite N/F.Q.	NQ/S.	A.S.N.
N/F.Q/S.	N.Q/S/P.	HN/P.
N/F.Q/P/S.		

CH. II.

The suffix letters indicate special characteristics as follows :—

- Q. The inclusion of a small amount of sodium cryolite.
- F. The use of wood cellulose.
- S. Slotted tube.
- P. The inclusion of a small amount of potassium sulphate.

37. A Solventless flashless propellant known as A.S.N. has been recently introduced. The letter A indicates that the propellant was originated by I.C.I., Ltd., at their Ardeer factory.

Cordite H.S.C./K./T.

38. This is a non-blinding cordite which was introduced originally for the 2-pdr. Mark VIII guns ; it is now superseding H.S.C./T. The letter " K " denotes the inclusion of a small amount of Potassium Cryolite.

AMERICAN PROPELLANTS**Nitrocellulose powders,**

39. The types of American nitrocellulose powders are N.C.T., N.H., and F.N.H.

40. N.C.T. (nitrocellulose, multi-tubular) consists of nitrocellulose in colloid form stabilised by diphenylamine. It is hygroscopic, and is of 1918 or earlier manufacture.

41. The modern powders, N.H. (non-hygroscopic) and F.N.H. (flashless, non-hygroscopic) are somewhat similar, their composition varies as the manufacturers use different compositions to reduce the absorption of moisture and flash. Unlike the cordites these propellants do not contain nitroglycerine.

42. Diphenylamine is a more effective stabiliser than mineral jelly being comparable with carbamate.

The propellants vary in colour from a light amber to a dark brown or black and are in the form of short cylindrical grains with one or seven axial perforations.

43. The diameter, length and web thickness of the grain are carefully designed to produce the required rate of burning. The critical dimension in this respect is the web size or thickness of propellant between the perforations measured radially at the end of the cylindrical grain. The mean of this dimension (to 1/1,000-inch) is given as the size for the propellant and follows the symbols of composition.

44. These propellants burn more slowly and more uniformly than Cordite S.C., and are therefore cooler and cause less erosion ; and variations in charge temperature do not affect the ballistics to the same extent.

The flash produced by nitro-cellulose powders is not so great as that from Cordite S.C. The flash produced by N.H. in guns of low velocity is very small.

With all three propellants there is slightly more smoke than with Cordite S.C. and an appreciable increase in blast.

45. In common with all propellants made from nitrocellulose a slow continuous decomposition which is accelerated by heat or direct sunlight takes place. Diphenylamine has been found to be very effective in controlling this decomposition.

46. As high temperatures change the density of these propellants, precautions must be taken to protect them from heat. Any marked change in the amount of solvent will result in a change in ballistics and the propellants are packed in airtight packages to guard against such changes.

CHAPTER III

HIGH EXPLOSIVES

CHIEF REQUIREMENTS.

55. The chief requirements of a Service High Explosive are :—

- (1) *Violence and Power.*—To produce the greatest possible shattering effect so that the maximum damage can be caused with a given quantity of material.
- (2) *Insensitiveness to Shock and Friction.*—With the exception of Initiators, High Explosives should be as insensitive as possible to shock or friction.
- (3) *Stability and Storage.*—Their properties must not alter appreciably during storage.
- (4) *To be unaffected by Damp or extremes of Temperature.*—Many High Explosives become inert if damp and special precautions must be taken to prevent ingress of moisture. Absorbed moisture may also cause chemical action resulting in the formation of dangerously sensitive compounds. Low temperatures are normally harmless, although the explosive may be rendered more difficult to detonate; high temperatures may cause partial liquefaction of the explosive.
- (5) *They should not form undesirable compounds with Metals.*—Various High Explosives react chemically with certain substances giving rise to objectionable products and contamination, e.g., T.N.T., picric acid (lyddite) and amatol react with alkaline substances and amatol and picric acid react with many metals. If metallic compounds are formed they may be very sensitive, which is dangerous; alternatively, they may be innocuous with a corresponding reduction in efficiency, which is undesirable. Containers for explosives are made of or coated with materials which do not interact with the explosive or produce either deterioration or a dangerous compound.
- (6) *Density.*—A high density is necessary to reach the maximum rate of detonation and to maintain the continuity of the explosive system against "set-back" on firing.

CLASSIFICATION.

56. For the purposes of this Handbook, Service High Explosives are classified into :—

- (1) Initiators.
- (2) Intermediaries.—Used to pick up the small but concentrated shock given by the Initiator and transform it into a sufficiently violent wave to detonate the main filling.
- (3) Shell and Bomb Fillings.

INITIATORS

57. Initiators are explosives used to detonate or explode other explosives. As they may only be used with safety in a small quantity whose detonation would not, by itself, cause complete detonation of a main shell or bomb filling, an Intermediary is used.

When detonation is required the Initiator must detonate with violence when subjected to flash, friction or percussion.

Where combustion is the requirement the Initiator must develop an intense flash when subjected either (1) to percussion, as in the percussion cap of a Small Arms Cartridge, or (2) to heat, as in an electric Tube.

A great variety of explosives produce combustion effects, but only fulminate of mercury and lead azide are used to initiate detonation. These two explosives are frequently mixed with other ingredients to modify the nature of the explosion.

Fulminate of Mercury.

58. Fulminate of mercury, the mercuric salt of fulminic acid, is an endothermic compound consisting of small grey or brown crystals having in bulk the appearance of fine sand; it is sometimes bleached white by the addition of copper salts during manufacture. It is poisonous and non-hygroscopic.

It detonates with violence, a small initial impulse bringing it rapidly to its full rate of detonation. The almost instantaneous explosive decomposition of a substance of such high density produces the intense blow required to detonate an explosive in contact with it. It is more sensitive to impact and friction than most high explosives and can be detonated by flash; but to ensure greater certainty of action it is usually mixed with other substances which ignite more readily.

As its extreme sensitiveness limits the quantity which can be used in a shell, an exploder system containing an intermediary is necessary with comparatively insensitive main fillings.

For transport in bulk it must be kept under water, only very small quantities being dried at a time as required. In the dry state fulminate of mercury is transported in metal containers and great

CH. III.

care must be exercised in handling them. It is always packed in a metal container as any leakage of so sensitive an explosive would be very dangerous.

Warm, damp storage has a harmful effect, decomposing it and tending to cause interaction with its metal container. In the presence of moisture it is readily decomposed by most metals (copper, brass and iron). It can be safely filled and compressed into metal containers if great care is taken. It must be well confined to obtain the full effect. Containers are varnished to prevent moist air entering.

Warm, dry storage renders it inert and incapable of initiating detonation, especially when used in a small quantity and compressed, as in 4- and 5-grain detonators.

Exposure to extreme temperatures or damp for a short period may not have an adverse effect, but these conditions should be avoided if possible.

59. Fulminate of mercury is used in fillings for detonators and ignitory caps. In the latter it is used in various mixtures termed Cap Compositions.

Lead Azide.

60. Lead azide, a compound of lead and nitrogen, is an endothermic compound consisting of very small white crystals having in bulk the appearance of fine sand; it becomes greyish brown if exposed to light. Practically insoluble in cold water, it decomposes if heated with water for a long period. Its properties are similar to those of fulminate of mercury, and like it, is poisonous.

Lead azide detonates with violence when subjected to shock or friction or when ignited by flash even when unconfined. It is slightly less sensitive to percussion than the fulminate compositions, and when used in detonators, may require the addition of a sensitizing layer of detonating composition on top of the azide.

It is more stable in storage than fulminate of mercury, being unaffected by warm dry conditions. It is not rendered insensitive by water; on the contrary, it may become more dangerous if stored wet for any length of time on account of the slow growth of large crystals which are extremely sensitive. If exposed to the atmosphere, especially when damp, it is gradually decomposed by carbon dioxide and loses its explosive power.

When compressed in closed detonators, its life is practically unlimited. It has a high density and, compared with fulminate of mercury, a smaller quantity is required to initiate detonation in other explosives.

61. Lead azide is used as a filling for detonators and for this purpose is superseding fulminate of mercury, on account of its superior stability. For percussion detonators a layer of a sensitive cap composition is added as it is not sufficiently sensitive and reliable to function alone.

Cap compositions.

62. Fulminate of mercury mixed with other substances is used as a primary means of initiating an explosive reaction as distinct from a detonating shock. These mixtures, known as Cap Compositions, are used in various detonators and percussion caps which are either pierced by a needle or struck against an anvil by a percussion striker.

63. The ingredients commonly included in Cap Compositions and their respective purposes are:—

Fulminate of Mercury	Sensitivity.
Potassium Chlorate	Aids burning and increases heat evolved.
Antimony Sulphide	Prolongs the flame effect.
Gunpowder	Aids flame effect and diminishes violence.
Sulphur	Diminishes the violence and reduces ignition temperature.
Ground Glass	Increases friction effects.

64. Characteristic compositions are:—

COMPOSITION	METHODS OF IGNITION		
	PERCUSSION (S.A. Cap)	PRICKING BY NEEDLE (1.7 grain detonation)	FRICION BAR (Friction tubes)
Mercury fulminate	8	6	—
Potassium chlorate	14	6	12
Antimony sulphide	18	4	12
Gunpowder	1	—	1
Sulphur	1	—	1
Ground glass	—	—	1

Note.—The figures in the Table refer to parts by weight.

INTERMEDIARIES

65. An Intermediary is a high explosive which is less sensitive than an Initiator but more sensitive than a main filling.

The function of an Intermediary is to link up and reinforce the exploder system of a shell or bomb by accelerating and intensifying the detonation wave. The Intermediary must be readily detonated by the Initiator and, by the violence of its detonation, must cause a complete detonation of the main filling.

Tetryl or Composition Exploding (C.E.).

66. C.E. (the Service name for trinitrophenyl-methylnitramine) is formed by the action of a mixture of nitric and sulphuric acids on dimethyl-aniline. It is a pale yellow crystalline substance with a melting-point of 129° C., soluble in acetone benzene, etc., but insoluble in water and not hygroscopic.

It is a violent high explosive of greater power than lyddite or T.N.T. and more sensitive than picric acid, readily inflammable and easily detonated. It is not used as a main filling except in certain Small Arms ammunition, *e.g.*, 20 mm. Hispano.

It responds readily to the impulse of an Initiator and its violent detonation ensures complete detonation of a main filling; it is more insensitive than fulminate of mercury.

It undergoes decomposition on melting, and for this reason is used in the form of powder or compressed pellets. It is less stable in storage than T.N.T., but it does not undergo serious deterioration in Service conditions. Chemically a neutral substance, it does not react readily with materials it is likely to come into contact with in the Service. Alkalis decompose it, but it is unaffected by exudation from T.N.T. Picric acid lessens its stability, and for this reason C.E. is not used as an exploder in lyddite shell. It does not require the use of lead-free conditions. To facilitate filling operations and to avoid the formation of dust, it is sometimes granulated or "corned" by treatment with a solution of gum arabic.

67. C.E. is used as a filling for the magazines of rifles and detonating fuzes. It is also used in Exploders of shell and bombs, in composite detonators and as a main filling for certain Small Arms ammunition, etc.

Picric Powder.

68. Picric Powder is a mixture of ammonium picrate (43 parts) and potassium nitrate (57 parts). It is a bright yellow crystalline substance prepared by mixing the finely ground ingredients in the dry state. More sensitive than picric acid, it ignites from a flash and burns rapidly to detonation when suitably confined. Its chemical stability is good provided it is kept dry. To prevent interaction with metals the same precautions are necessary as for picric acid.

69. Picric powder is used as an exploder in certain lyddite filled shells when the explosion is brought about by means of a flash from gunpowder and not by a detonating system.

T.N.T. crystals.

70. T.N.T. crystals are extensively used in Exploders. Owing to their susceptibility to T.N.T. exudation from the shell filling they are being superseded by C.E., except in lyddite or shellite filled shell.

SHELL AND BOMB FILLINGS

71. High explosive fillings for shell and bombs are very insensitive and difficult to detonate. Shell fillings must be sufficiently insensitive to withstand the shock of discharge from a gun and in Piercing Shell to withstand the shock of impact with armour. Stability in storage is important as filled shell cannot be inspected so easily as propellants. Moisture may affect a filling by increasing its volume and forcing some of the filling from the shell or bomb by partially dissolving a constituent of the filling or causing chemical action. When a shell bursts the detonation of the filling should provide smoke for spotting.

Lyddite or Picric Acid.

72. Picric Acid or trinitrophenol, when cast in shell, is known as Lyddite. It is obtained either by the action of sulphuric and nitric acids on phenol (carbolic acid) or less directly from coal tar benzene. Picric acid is a yellow crystalline solid melting at 121.6° C., and is slightly soluble in cold water.

It is a violent high explosive, more sensitive than most main fillings, but it requires a powerful detonating impulse to give complete detonation. If the detonating impulse is insufficient, a milder explosion is produced and some of the filling remains unexploded. It is not sufficiently insensitive to withstand impact on armour and is thus unsuitable for armour-piercing projectiles.

Picric acid is very stable in storage provided it is kept dry. It is not adversely affected by temperature, and is especially suitable for storage in hot climates on account of its high melting-point and freedom from impurities of a lower melting-point. As moisture aggravates the tendency to form

C H. III.

dangerous compounds with metals, great care must be taken in sealing shell. It is a medium acid and reacts with metals and many compounds to form salts known as picrates. Some picrates, particularly lead picrate, are very sensitive to shock and detonate with violence when struck or ignited. Picrates are a source of danger, since they can function as initiators and bring about the detonation of lyddite in contact with them. Great care is taken to prevent their formation; a protective film is varnished between the acid and the surfaces of the metal containers and lead-free materials only are used. Copal varnish (lead-free), sprayed on the inside of projectiles and containers, produces an elastic resistant layer.

On complete detonation lyddite gives a black smoke of carbon particles; on incomplete detonation, the smoke is tinged with yellow.

73. Lyddite was formerly used as a main filling for High Explosive shell. Because of the difficulty in filling and the precautions necessary to prevent interaction with metals, it has been replaced by less reactive explosives, except in shell to be stored in hot climates. The principal use of picric acid now is as an ingredient of Shellite.

T.N.T. (Trinitrotoluene).

74. T.N.T. is formed by the action of nitric and sulphuric acids on toluene, a liquid similar to benzene and obtained from coal tar or Borneo petroleum. It is a pale yellow crystalline solid practically insoluble in water and is not hygroscopic, but is readily dissolved by organic solvents such as benzene or acetone; it is poisonous. The Service uses two grades; Grade I has a melting-point not below 80° C., and Grade II not below 79.5° C. It is a violent and powerful high explosive, only slightly inferior in these respects to picric acid. It burns readily when ignited and considerable quantities have been burned without explosion occurring. Rather more insensitive than picric acid, its stability in all grades is satisfactory, and there is no danger of spontaneous ignition. With the lower grades, exudation of oil may occur in warm conditions of storage; this oil is explosive in character, and if it should get into the screw threads of shell it might give rise to premature explosion on firing. A powerful impulse and strong confinement are necessary to ensure satisfactory detonation, especially when in the cast condition. T.N.T. is not adversely affected by temperature and is a relatively non-reactive substance. Free from acid properties when pure, it has not the tendency as picric acid to form sensitive salts.

On complete detonation T.N.T. gives a black smoke of carbon particles; on incomplete detonation the smoke is grey.

T.N.T. is superseded by R.D.X./T.N.T. as the main filling for all calibres of H.E. shell. T.N.T. is the main filling for all Piercing Shell below 8-inch.

75. T.N.T. is also used as a filling for bombs, depth charges and other high explosive munitions. It has superseded guncotton for demolition charges. It is also used in the form of pressed pellets for Exploders and detonating fuzes.

T.N.T.—B.W.X.

76. For armour-piercing shell the sensitiveness of the T.N.T. filling may be reduced by an admixture of beeswax. This filling is fed into the shell by a special process (Para. 264). It is also used as a main filling in H.E. aircraft bombs.

Shellite.

77. Shellite is the name given to cast mixtures of picric acid and dinitrophenol. The mixture normally employed contains 70 per cent. of picric acid and 30 per cent. of dinitrophenol. It is a yellow crystalline solid melting at approximately 76° C. It possesses the poisonous properties of dinitrophenol and should be handled with care. Shellite is a violent and powerful High Explosive, only slightly inferior in these respects to picric acid. It is rather more insensitive than picric acid to which it is similar in stability and keeping properties. As both of its ingredients are acid, shellite requires the same precautions against contact with metals as picric acid. It has a comparatively low melting point which is an advantage for main filling.

78. Present policy is to use shellite as the main filling for all Piercing Shell 8-inch calibre and above. It is also used as a main filling in A.P. aircraft bombs.

R.D.X.

79. This is the most powerful modern explosive used as a shell main filling. It is approximately 30 to 50 per cent. more powerful than T.N.T.

Like picric acid and T.N.T., R.D.X. is a trinitro compound. It is too sensitive to be used alone, and in the Service it is mixed with T.N.T. or beeswax. R.D.X./Beeswax is used for Q.F. 2-pdr. H.E. shell, 40 mm. Bofors, and is also intended for use in Piercing shell. R.D.X./T.N.T. is the present main filling for all calibres of H.E. shell.

P.E.T.N.

80. P.E.T.N. (Penta-erythritol-tetranitrate) is more sensitive than R.D.X., and must be mixed for Service purposes with a nitro body or an inert deadening agent. Mixed with T.N.T. it is known as Pentolite, the usual mixture consisting of equal parts of the two ingredients.

Pentolite (P.E.T.N./T.N.T.50/50) has only been used for 20 mm. Oerlikon H.E. shell of American make and 20 mm. Hispano H.E. shell. It has been approved as an alternative filling to C.E. for the magazines of all nose fuzes and gaines.

Amatol.

81. Amatol is a mechanical mixture of ammonium nitrate and T.N.T. The constituents are mixed in various proportions which are indicated by a fraction following the name, for example, Amatol 60/40 contains 60 per cent. ammonium nitrate and 40 per cent. T.N.T. The first number always refers to the percentage of ammonium nitrate.

The Amatols are powerful and violent main bursting charges. Rather more insensitive than T.N.T., they are safe to handle. They retain the poisonous and irritant properties of T.N.T. They detonate powerfully when suitably initiated, but being comparatively insensitive they require a special exploder system to give complete detonation. Ammonium nitrate is very hygroscopic, and amatols also have this rather serious defect. Moist ammonium nitrate when in contact with copper or its alloys forms sensitive blue crystalline explosive salts. This defect requires the prevention of access of moisture to an explosive charge and the varnishing of all copper-containing components with which the explosive may come into contact.

82. Amatol is used as a main filling in bombs, depth charges, mines and large demolition charges. It is not used as a filling in Naval Service Shell.

Baratol.

83. Baratol is a mechanical mixture of barium nitrate and T.N.T. Barium Nitrate is a much heavier substance than ammonium nitrate, and, weight for weight, Baratol is inferior to Amatol as an explosive, although volume for volume there is little difference. Baratol is not hygroscopic nor is it materially affected by high temperature of storage. It does not attack copper to form sensitive salts. It detonates even when not tamped.

84. Baratol is used as a main filling for Hand or Rifle grenades whose detonators are contained in copper sheaths.

SCHEDULE OF HIGH EXPLOSIVES

(1) EXPLOSIVE	(2) PHYSICAL STATE	(3) COLOUR	(4)		(6) DENSITY	(7) RATE OF DETONATION FEET/SEC.	(8) POWER (Lead block test) (Picric acid = 100)	(9) FIGURE OF MERIT (Picric acid = 100)	(10) USE	(11) REMARKS	(12) Page in Test
			MELTING POINT DEGREES	IGNITION TEMPERATURE CENTIGRADE							
<i>Picric Acid</i> (Lyddite)	Crystals	Intense Yellow	121.6	Above 250	1.6 (cast)	23,925	100	100	Filling for shell and torpedo heads; exploders for shell; demolition charges.		72
T.N.T. (Grade I)	Crystals	Pale Yellow	76-80	240	1.56 (cast)	22,934	99	115			74
<i>Shellite</i> 70/30	Crystals	Yellow	76-100	Above 250	1.6-1.63 (cast)	22,440	85	116	Filling for piercing shell		77
R.D.X.	Crystals	White	202	213	1.7-1.8 (absolute)	27,720	164	68		Too sensitive to be used alone	79
P.E.T.N.	Crystals	White	140	145-150	1.73 (absolute)	27,390	165	40		Too sensitive to be used alone	80
<i>Fulminate of Mercury</i>	Crystalline Powder	White, Grey or Brown	—	160	4.43 (absolute)	14,850	39	10	Detonators and caps.		88
<i>Lead Azide</i>	Crystalline Powder	White or Buff	—	Above 250	4.81 (absolute)	14,850	37	15 to 25	Detonators.		60
<i>Cap Composition</i>	Compressed Powder	Black	—	About 140	—	—	—	7 to 10	Igniferous caps and detonators.		62
C.E. (Tetryl)	Crystals	Pale Yellow	129	180	1.45 to 1.55 (pressed)	24,816	120	70	Filling for magazines of detonating fuzes and fuzes; primers for mines, depth charges, etc.; exploders for shell and bombs. Also 20 mm. shell fillings.		66
<i>Picric Powder</i>	Powder	Orange	—	Above 250	1.45-1.55 (pressed)	—	—	87	Explosor for Lyddite and shellite fillings.	Mixture of Ammonium Picrate & Potassium Nitrate.	68
<i>Genacton</i>	Fibrous Solid	White	—	187	1.67 (wet absolute) 1.0-1.2 (wet pressed)	24,090 (dry) About 18,150 (wet)	115 (dry) 95 (wet)	23 (dry) 120 (wet)	As a constituent of cordite.		—
<i>Distiophend</i>	Crystals	Yellow-Brown	110-114	Above 250	1.64 (cast)	20,196	60	Over 120	As a constituent of shellite.	Not used as an explosive alone.	—
<i>Ammonium Nitrate</i>	Crystals	White	170	—	1.72 (absolute)	4,850-8,250	—	Over 120	As a constituent of amatol.	Not used as an explosive alone.	—
<i>Amatol</i> 80/20	Solid	Light Yellow	—	235	1.25-1.5 (pressed)	16,764	127	111 to 120	Bombs, large demolition charges.		81
60/40	"	"	—	—	1.5 (cast)	21,450	—	—	Mines, Depth Charges.		—
<i>Nitroglycerine</i>	Liquid	Colourless	13	188	1.6	24,750-26,400	160	13	As a constituent of cordite.	Too sensitive to be used alone.	—

CHAPTER IV
GUNPOWDER AND PYROTECHNIC COMPOSITIONS

GUNPOWDER

90. Gunpowder consists of potassium nitrate, charcoal and sulphur mixed together in the approximate proportions 75 : 15 : 10. Gunpowders containing the ingredients in somewhat different proportions are used for special purposes, such as the propelling charge for rockets, the time rings of fuzes, etc.

The three ingredients are ground together in a moist condition and the mixture is compressed and dried. The press cake produced is broken up and the grains thus formed are sieved to obtain powders of homogeneous grain size and to remove dust and lumps. The grains, which vary in colour from black to brown, according to the type of charcoal used, are usually glazed; this is effected by polishing in a rotating drum, either with or without the addition of a little graphite.

91. Powders of the following different grain size are in Service :—

SIZE	BRITISH STANDARD SIEVE	
	<i>Passed by</i>	<i>Retained by</i>
P.3 (Pebble powder)	$\frac{3}{8}$ inch	$\frac{3}{8}$ inch
G.3	$\frac{3}{8}$ inch	$\frac{1}{8}$ inch
G.7	$\frac{1}{4}$ inch	No. 8 sieve
G.12	No. 8 sieve	No. 16 sieve
G.20	No. 16 sieve	No. 25 sieve
G.40	No. 25 sieve	No. 52 sieve
Mealed powder	No. 150 sieve	No. 240 sieve

Ingredients and Properties.

92. The ignition temperature of gunpowder varies between 285° C. and 300° C., according to the nature of the powder and the rate of heating. It is thus readily ignited by flame or spark, and for this reason is widely used as a priming. Although it can be subjected to moderate shock or friction without ignition, it may be ignited by a comparatively light blow if nipped between hard surfaces. When ignited, gunpowder burns vigorously with the evolution of considerable quantities of white smoke; more than half (56 per cent.) of the products of combustion condense to solids on cooling to ordinary temperatures. This production of smoke and of solids which cause rapid fouling of weapons, are two of the major disadvantages of gunpowder as a propellant.

The properties of gunpowder as an explosive are determined by its physical nature. Since it is a mechanical mixture of substances, none of which are themselves explosive, reaction must take place between particle and particle; as a result of this, gunpowder cannot be detonated, and produces its full explosive effect only when caused to ignite in a sufficiently confined space. The rate of explosion is determined by the size, composition and density of the grains; e.g., a fine, unglazed powder consisting of light, porous grains burns more rapidly than a coarse, highly glazed, dense powder.

Gunpowder can be stored indefinitely in a cool, dry place. In damp conditions, however, it absorbs moisture and cakes together with the result that its explosive properties are impaired. Excessive wetting may cause the solution and segregation of some of the potassium nitrate, and when that happens its explosive properties are not fully restored by drying.

Metal tools for working with gunpowder are made of copper or bronze to minimise the risk of accidental ignition from sparks.

Service uses.

93. Gunpowder is used for a variety of purposes in the Service, e.g. :—

- (i) Igniters for Cartridges, B.L.
- (ii) As the delay composition in fuzes and gaines.
- (iii) Magazines of fuzes, tubes and primers.
- (iv) Time rings of fuzes.
- (v) In the form of grains or perforated pellets for the connecting pellets in fuzes.

CH. IV.

- (v) Bursting charges for Shrapnel and Base Ejection shell.
- (vi) Combustible compositions, *e.g.*, priming, quickmatch and cap compositions.
- (vii) Charges of B.L. and Q.F. blank cartridges.
- (ix) Propellant charges for rockets, signal cartridges and other pyrotechnic stores.

Sulphurless gunpowder.

94. Sulphurless gunpowder is a mixture of 70 parts of potassium nitrate and 30 parts of charcoal. Its properties are very similar to those of ordinary gunpowder, and it is used in place of gunpowder in stores where contact occurs with materials which are adversely affected by sulphur or which form sensitive mixtures with it. Thus, compositions containing magnesium or chlorates are primed with sulphurless gunpowder.

PYROTECHNIC COMPOSITIONS

95. Pyrotechnic compositions are, with few exceptions, solid mixtures. Most of them in the loose condition are easily ignited and some burn explosively. The compositions are all mixtures of fuels and oxidising compounds to which other ingredients may be added for specific purposes. Among the common fuels are magnesium, aluminium, silicon, calcium silicide, zinc, charcoal, milk-sugar, starch and certain natural and synthetic resins. The oxidising compounds include the nitrates of potassium, sodium, barium and strontium; the chlorates and perchlorates of potassium and barium and the oxides or peroxides of iron (hammer-scale) manganese, barium and strontium. Owing to the greater danger involved in their use, compositions containing chlorates and perchlorates are avoided where possible. The other ingredients which are added may play no essential part in the combustion but confer certain special properties on the composition. Thus, drying oils, waxes, natural and artificial resins are used to protect powdered metals in the compositions from corrosion; these materials also assist the consolidation of compositions which have to be pressed.

Chromates and boric acid are also used to protect metallic constituents from corrosion. Gums or spirit soluble varnishes are sometimes used as binders when the composition is to be granulated or applied as a paste. Halogen compounds, such as metallic chlorides and organic compounds containing a high proportion of chlorine, are employed to intensify flame colour. Relatively inert materials such as graphite, carbonates, oxalates and china clay may be added to regulate the rate of burning.

96. Pyrotechnic compositions are prepared by mixing the previously ground ingredients by sieving or in a mechanical mixer. The rate of burning and stability of any composition is considerably affected by the fineness of the ingredients, and this is therefore closely controlled; in particular, magnesium is available in six grades differing in the size of the particles and the bulk density and each grade has its special applications.

In Service stores pyrotechnic compositions are required to burn in a regular and controlled manner. In order to ensure this they are usually compressed under a high pressure, sometimes directly into the store and sometimes as a bare pellet or into a paper or metal case which is then assembled into the store. The rate and regularity of burning are also dependent on the free escape of the products of combustion, and this must be provided for in the design of stores.

Many pyrotechnic compositions are sensitive to friction and are easily ignited by a spark. They must not, therefore, be subjected to blows or grinding friction, and must be consolidated by steadily applied pressure in shielded presses. Non-ferrous tools, without sharp points or edges are used whenever possible.

Service compositions are stable when perfectly dry. If moisture gains access to the composition (*e.g.*, through ineffective sealing of the store) deterioration may set in rapidly, particularly in those compositions containing aluminium or magnesium.

Pyrotechnic compositions are classified according to their use as illuminating, signal, smoke and incendiary compositions.

Illuminating compositions.

97. These give an intense light and are used in star shell, flares, tracers, flash bombs, etc.

Most compositions of this type are mixtures of magnesium and an oxidising agent; certain other ingredients may be added to colour the flame.

Signal compositions.

98. These are used in signal rockets, signal cartridges, signal flares, etc. In these stores a distinctive effect is necessary; this is achieved partly by the design of the store (*e.g.*, the expulsion of stars) and partly by the compositions (*e.g.*, the emission of coloured light). The coloured effect is secured by using the chloride, chlorate or oxalate of the appropriate metal; strontium salts give red, barium salts a green, sodium salts a yellow and copper salts a blue effect. The visibility of the colours is somewhat dependent on the atmospheric conditions.

Compositions for use in daylight signals must produce a large amount of light and are similar to illuminating compositions. Coloured smokes (*see* Smoke Compositions, *para.* 99) are sometimes used as daylight signals.

Compositions for signals designed for night use do not have to produce so much light as the compositions for daylight use, and a greater variety of ingredients can be used as the fuel, *e.g.*, charcoal, starch, acaroid resin.

Smoke compositions.

99. Smoke is employed either for screening or for signalling, and the type of composition used depends on the purpose to which it is to be put.

Smoke used for screening purposes is usually white. It is produced by dispersing a cloud of small particles which attract moisture from the air and thus produce a dense fog. The particles may be produced by dispersing a hygroscopic liquid such as chlorosulphonic acid, fuming sulphuric acid or titanium tetrachloride, by burning phosphorus in air, or by producing zinc chloride vapour by the combustion of zinc or zinc oxide with hexachloroethane or carbon tetrachloride.

The white phosphorus is filled into shell (*para.* 302). On firing the shell, the phosphorus is scattered by an explosive charge and ignites spontaneously in the air. Though producing a good smoke, phosphorus is not satisfactory owing to the tendency of the smoke to rise off the ground (pillaring).

The hexachloroethane and carbon tetrachloride compositions are filled into generators and ignited by means of a hot priming composition. Hexachloroethane smoke containers may be base-ejected from shell (*para.* 298), but carbon tetrachloride compositions are used only in static generators. These compositions produce a satisfactory smoke which shows no tendency to pillaring; they are, however, liable to deterioration in the presence of small quantities of water, and the containers must be well sealed.

In order to increase the visibility of shell bursts, shells containing some fumyl may be used. This is an explosive mixture (T.N.T.—ammonium nitrate—ammonium chloride) which produces a puff of smoke when it is detonated. (*Para.* 290.)

Signal smokes are used in a small number of stores for daylight signalling. Red and orange smokes are used as distress signals by dinghies, and certain coloured smoke signals are used by submarines. The compositions consist of a solid dyestuff mixed with milk-sugar and potassium chlorate. The sugar and potassium chlorate produce a flame sufficiently hot to vaporise the dye but not so hot as to decompose it.

Calcium phosphide ignites on contact with water, producing both smoke and flame. Marine markers for both day and night use and submarine smoke candles are filled with this material.

Incendiary compositions.

100. Phosphorus and pyrotechnic compositions containing powdered aluminium or magnesium produce heat on combustion, and therefore have an incendiary effect. Thermite, which is a mixture of iron oxide and aluminium powder, is also used as an incendiary material.

Magnesium metal, when heated to its melting point, burns in air with evolution of intense, though localised, heat, and is a very efficient incendiary material. It is used in the standard 4 lb. incendiary bomb, some thermite being used to melt the metal.

In some cases a liquid hydrocarbon (*e.g.*, petrol or benzol) is used for incendiary purposes. To prevent too rapid combustion and excessive scatter of the fuel it is thickened by the addition of a small amount of a suitable gelling agent.

Incendiary agents may be used in bombs, shell or S.A.A.

101-104.

CHAPTER V

CHARGE WEIGHTS

DETERMINATION OF CHARGE WEIGHTS.

105. Propellant charges are determined to give :—

- (1) The maximum muzzle velocity possible with a certain size of cordite without exceeding a given pressure, or
- (2) a certain velocity to meet definite requirements.

A charge may be made up to a Nominal Weight, an Adjusted Weight or a Fixed Weight.

NOMINAL WEIGHT.

106. The charge weight required is calculated theoretically and checked by a firing trial in a gun. From the results of this firing a corrected charge weight is calculated for subsequent use ; this weight is known as the nominal weight of the charge. Charges are filled to a nominal weight when accuracy of muzzle velocity is not of primary importance, *e.g.*, charges for Star Shell, Target Smoke Shell, and Gunnery School Special Charges.

ADJUSTED WEIGHT.

107. Lots of cordite of the same nominal size differ slightly from each other in ballistics. With a view to minimising differences between Lots the general practice is for the actual weight of a charge to be adjusted for each Lot. To calculate the adjustment required, three (or in smaller guns, five) rounds of nominal charge weight of each Lot are fired under standard conditions against a standard Lot of cordite. Adjustment is made on the results of these rounds by calculating the amount of cordite of the same Lot to be added to or withdrawn from the nominal charge weight to obtain a certain velocity ; this velocity differs for each type of gun and is known as " the velocity of adjustment." An adjusted charge of a Lot should, within the limits of experimental error, give correct ballistics in a gun in the same state of wear as that used for its proof. In guns in other stages of wear some small differences in ballistics between the Lots may be experienced in spite of the adjustment of the charge, as the loss of velocity due to wear of the gun differs to some extent from Lot to Lot ; with Cordite S.C. the error due to this should be small.

FIXED WEIGHT.

108. In certain guns the ballistics of Lots of Cordite S.C. are found to be sufficiently regular from Lot to Lot to enable proof to be dispensed with and a fixed weight of charge to be adopted. In such cases the fixed charge-weight is an average of the adjusted charges of Lots already proved.

REDUCED CHARGES

109. Although Lots are adjusted to give as far as possible the same muzzle velocity with their full charges, this adjustment cannot be guaranteed to hold with their reduced charges. Good spreads cannot be expected with reduced charges of Cordite S.C. if mixed Lots are used in the same broadside or salvo, though the effect with Cordite S.C. will not be as serious as it used to be with Cordite M.C. Supply conditions may sometimes necessitate the use of three-quarter charges made up of a half charge of one Lot and a quarter charge of another Lot. Such charges cannot be expected to give correct ballistics, and their use should be restricted to firings where spread is of minor importance.

The above remarks on reduced charges apply only to those guns in which the reduced charge is a fraction of the full charge.

CHAPTER VI
CARTRIDGES FOR B.L. GUNS

GENERAL REMARKS

115. For safety, protection, convenience in handling and rapidity in loading the propellant charge for a B.L. gun is packed into a silk bag (with or without an igniter) and is termed a "Cartridge, B.L."

The charges for the larger B.L. guns are too heavy and bulky to be handled in the form of a single cartridge and the charge is divided into fractions; each fraction is made up into a Cartridge, B.L. These Fractional Charges are identified by their fraction, e.g., " $\frac{1}{2}$ charge," " $\frac{1}{4}$ charge," etc.

Particulars of Fractional Charges approved for the various B.L. guns are set out in the *Table in para. 139.*

Cartridges, B.L. are cylindrical, except certain Star Shell Cartridges which are shaped like a dumb-bell to ensure that the igniter is in line with the vent.

116. Charges for B.L. guns using a .4-inch or a .5-inch tube require one or more gunpowder igniters. Igniters are not fitted to each of the Fractional Charges for B.L. guns 14-inch, 15-inch and 16-inch, and the open end of the bag of those Fractional Charges without an igniter is closed with a silk cloth disc of the same colour as the bag. Cartridges, B.L. for 6-inch Mark XXII guns and below have the open end of their bag closed with an igniter.

Charges for B.L. guns using a 1-inch tube (6-inch Mark XXIII and 8-inch) are not fitted with an igniter as the flash from the tube is powerful enough to ignite the bare charge. A red silk cloth disc is sewn to the cartridge in the place of the igniter.

The number of igniters approved for full and reduced charges for the various guns is given in the *Table in para. 139.* Cartridges, B.L. must be loaded into the gun with the igniter or the red silk cloth disc of the igniterless charge towards the vent.

CARTRIDGES, B.L. *Plate 1*

117. The components of a Cartridge, B.L. are:—

- (i) The charge.
- (ii) Tinfoil.
- (iii) Silk bag with an igniter or silk cloth disc and lifting bands.

The Charge.

118. The bundling of the cordite for a Cartridge, B.L. is determined by the overall length and diameter to which the complete cartridge must conform and to the dimensions of the gun chamber, hoists, etc. For example, the charge for the B.L. 15-inch gun is made up into four Fractional Charges whose cordite is cut into lengths of about $24\frac{1}{2}$ inches. The cordite is formed into a cylindrical bundle and tied with silk webbing to ensure rigidity. The exact weight depends on the adjustment of the particular Lot of cordite used and each Fractional Charge weighs approximately 108 lbs.

Tinfoil.

119. Tinfoil is used with most Cartridges, B.L. to prevent coppering of the bore of the gun. (Lead foil may be used as a substitute.) Where foil is used the word *FOIL* is stencilled on the bag.

On firing, the tinfoil is volatilised and the hot surface of the bore is sprayed with minute particles of molten tin-lead alloy of a much higher temperature than the bore. Alloying of the copper left by the driving band takes place very rapidly and the deposit, which is of a brittle or powdery nature, is largely removed by the rush of gas or by the driving band of the next round; any residue is easily removed if the bore is cleaned with a wire brush.

Tinfoil in cartridges for B.L. guns 6-inch and above is used in the form of thin circular discs which are approximately two-thirds of the diameter of the cartridge. The discs are placed in the bottom of the cartridge bag and are covered with a shalloon disc which is then sewn in.

The tinfoil in Fractional Charges for B.L. 6-inch guns is fitted in the ends of the $\frac{3}{4}$ and $\frac{1}{2}$ charges which are laced together.

The tinfoil in Cartridges for B.L. guns below 6-inch is wrapped round the charge.

Cartridges, B.L. with double the usual amount of tinfoil may be fired to clear copper deposit in the bore, and for this purpose additional tinfoil is stitched round or across the bottom of the cartridge.

Silk Bag.

120. The silk cloth bag into which the charge is packed is termed a "Cartridge, B.L., Empty."

The material for a cartridge bag must possess special qualities:—

- (i) It must be strong enough to stand the wear of handling and transport.

CH. VI.

- (ii) It should have good keeping qualities and should not be seriously affected by chemical action of the explosive, and
- (iii) On firing, it should be entirely consumed in the gun. It must not leave any smouldering fragments or sparks in the chamber or bore.

Silk cloth satisfies these requirements, and the majority of cartridge bags for charges over 10 lbs. in weight are of silk cloth.

Cream serge may be used for bags for charges up to 10 lbs., but it is unsuitable for certain propellants.

Substitutes for both silk cloth and silk webbing are undergoing trials and may be introduced.

Lifting Bands.

121. Lifting Bands of tape, webbing or braid are fitted to all Cartridge bags B.L. (except those for B.L. 6-inch Mark XXIII guns (*para.* 141)) to assist their removal from the magazine case. The latest cartridges are fitted with a "Harness" form of band.

The Lifting Bands are removed when the charge is withdrawn from its magazine case to be passed to the gun. If the return of the charge to its case is permitted by N.M. & E.R. the Lifting Bands and Cardboard Protecting Tube (if fitted) should be replaced.

During hostilities, cartridges for B.L. guns 4.7-inch and below have only the last cartridge of a layer in a case fitted with a Lifting Band.

Lifting Bands are still fitted to all reduced charges with a stalk end and with only one igniter.

In older Cartridges, B.L. above 6-inch, bands are passed through fairleads of silk or shalloon braid on the sides and the bottom of the bag and the ends are secured with a bow hitch; this type of band is obsolescent.

For convenience in handling, some older cartridges for B.L. guns 14-inch and above have lifting beackets sewn to the bag at the non-ignitered end. End beackets and fairleads for lifting bands are obsolescent.

Igniters.

122. There are two types of igniter—the Plate Igniter and the Concentrated Igniter.

Plate Igniters (*Plate 2*) consist of two discs of red shalloon, sewn together at the edges, with a silk cloth or cream serge disc sewn to the under side. The shalloon discs are divided into parallel compartments which are filled with R.F.G.2 or G.12 powder, this ensures an even distribution of gunpowder. The igniter is fitted over the open end of the cartridge bag, and its silk cloth or cream serge disc prevents the cordite perforating the shalloon disc.

Concentrated Igniters (*Plate 1*) ensure greater regularity in ignition and, having a smaller exposed area than the plate igniter, afford better protection against flash. They are fitted to cartridges for B.L. guns 14-inch, 15-inch and 16-inch. These igniters have similar components to Plate Igniters, but the stitching is in concentric circles. The igniter is of less diameter than, and is recessed into, the end of the cartridge.

Igniters are marked as follows:—

- (i) Contractor's initials.
- (ii) Calibre of gun.
- (iii) Letters "IG" followed by a letter or number denoting the pattern of igniter.

Igniter Covers.

123. Igniter covers are fitted over igniters to protect them from flash and damage in handling and transport.

124. Some cartridges for B.L. guns 8-inch and below are fitted with an igniter cover of double silk cloth secured by a drawstring. The cover fits over both the igniter and the end of the cartridge and must be removed before the cartridge is loaded. Beackets (coloured red) are also fitted to facilitate the removal of the cover. The cover is marked "Remove Rear Cover before firing."

125. Tear-off Discs, a form of igniter cover now obsolescent, were fitted to cartridges for B.L. guns 14-inch and above. The Tear-off disc consists of a millboard disc covered with silk cloth and marked with a red cross. It is fitted over the igniter and is torn off before firing, i.e., at the last stage in handling the cartridge. In later patterns the silk cloth overlaps the edge of the cartridge and is drawn in with a drawstring of white tape.

126. The latest type of cover is the "Non-Removable Igniter Cover." This cover is of red coloured three-ply fabric (tinfoil with cashmere facings) sewn to a wall of silk cloth in the form of a cap. It is fitted over the igniter and the bottom of the cartridge bag and is sewn to the igniter and the bag. It is not removed before firing.

The cover is supplied for all ignitered cartridges for B.L. guns using a .5-inch Tube.

Cartridge, Drill, B.L.

127. Drill Cartridges are of wood with a lead or iron core for weight; they are covered with raw hide. The ends are painted red with the word "DRILL" in white letters. These cartridges are used for loading drills and have the same weight and outside dimensions as the Service charge.

Drill cartridges for the B.L. 8-inch guns have sponge rubber pads at each end to prevent damage to the cordite hoist buckets.

Cartridges, Drill, Loading Teachers reproduce the flexibility of a Service cartridge and consist of lengths of rope, jute, hemp or manilla bunched together and contained in a canvas bag. When representing ignited cartridges they are fitted with "covers, igniter, drill." These cartridges have red coloured canvas ends with the word "DRILL" in black; the words DRILL, LOADING TEACHER are printed on the side in black.

Markings.

128. Cartridge bags are marked as follows:—

On one side:—

- Numeral of the cartridge and the word "Foil."
- Initials or trade mark of maker of the bag.
- Nature of gun (and mark of gun in the case of B.L. 6-inch, Mark XXIII).
- Weight of charge.
- Nature and size of cordite used.
- Fraction denoting size of charge, e.g., $\frac{1}{4}$, etc.
- REPd—denotes that the cartridge has been repaired.

On the other side:—

- Letter "N."
- Lot number of cordite and sub-lot number, if applicable
- Monogram of filing station.
- Date of filling (month and year).

TYPES OF CHARGE FOR B.L. GUNS

129. The types of charge for B.L. guns are:—

- | | |
|--------------------|--------------------------------|
| Full Charge. | Super Charge. |
| Reduced Charge. | Bombardment Charge. |
| Star Shell Charge. | Special Gunnery School Charge. |

Full Charge.

130. The Full Charge is the Service charge for a gun. It may be made up into a single Cartridge, B.L. or into Fractional Charges. For B.L. 6-inch guns a $\frac{2}{3}$ charge and a $\frac{1}{3}$ charge are laced together to form one cartridge.

Reduced Charge.

131. The Reduced Charge is used for practice firing, and unless it is a Special Reduced Charge, usually consists of one or more Fractional Charges.

Particulars of Reduced Charges approved for the various B.L. guns are set out in the Table in *para.* 139.

Star Shell Charge.

132. Special reduced flashless charges for Star Shell are made up into a single Cartridge, B.L. for B.L. guns 4-inch and 4.7-inch.

Super Charge.

133. At present the use of Super Charges is confined to a limited number of B.L. guns 6-inch, Mark XII and 15-inch, Mark I, whose role calls for a longer range than the Full Charge will provide.

Bombardment Charge. *Plate 2.*

134. Bombardment Charges are special reduced charges which give shell a steep angle of descent at short ranges.

135. Charges are in supply for B.L. guns 6-inch, Mark XII and 6-inch, Mark XXIII. They are similar in make-up for each gun, except that the charge for the 6-inch, Mark XII is fitted with a gunpowder igniter, while that of the 6-inch, Mark XXIII is igniterless.

136. The charge, consisting of Cordite S.S.C. in two portions, is supplied fully assembled and is known as Bombardment Charge No. 2.

The core of Portion No. 1 is of "Stalk" construction, the stalk being eccentric to the body. Portion No. 2 is saddle shaped and is secured to the stalk of Portion No. 1 by two ties of shalloon braid.

Bombardment Charge No. 1 consists of the core or Portion No. 1 only. To adjust to Bombardment Charge No. 1 the shalloon braid is untied and Portion No. 2 removed.

CH. VI.

137. Portions removed in adjusting charges are to be thrown overboard in deep water. When this is not possible, they are to be dealt with as directed by Article 42 of N.M. & E.R.

Packages containing Bombardment Charges are stencilled "BOM."

Special Gunnery School Charges.

138. Gunnery Schools are supplied with special reduced charges (less than normal reduced charges). The charges may be made up with old Cordite or Cordite which is considered no longer suitable for Service.

139. TABLE OF FRACTIONAL AND REDUCED CHARGES AND IGNITERS.

B.L. GUN	FRACTIONAL CHARGE	NUMBER OF IGNITERS	REDUCED CHARGE
16-inch	$\frac{1}{2}$	Two per Full Charge	Special Reduced Charge
15-inch }	$\frac{1}{2}$	Two per Full Charge	
14-inch }	$\frac{1}{2}$	Two per Full Charge	
8-inch	$\frac{1}{2}$ and $\frac{1}{4}$	No igniter	
6-inch, Mark XXIII	$\frac{1}{2}$ and $\frac{1}{4}$	No igniter	
6-inch earlier	$\frac{1}{2}$ and $\frac{1}{4}$	One on each Fractional Charge	
4.7-inch }	Special Charge	One	
4-inch }			

CARDBOARD PROTECTING TUBES, CONTAINERS, WRAPPERS AND CLARKSON'S CASES. Plate 34.

Cardboard Protecting Tubes.

140. Cartridges, E.L. with "Stalk" front ends have Cardboard Tubes fitted loosely over the stalks to prevent distortion during stowage in the magazine cases.

Overall Lifting Bands are passed through slots in the Cardboard Tubes, and when the bands are removed the Cardboard Tubes will also be withdrawn.

Cardboard Tubes must not be loaded into the gun with the cartridges, and each tube is stencilled "Tube, Protecting Stalk only—not to be loaded into the gun."

Containers. Plate 34.

141. Cartridges, B.L., for 6-inch, Mark XXIII guns are supplied in cylindrical rolled paper containers in which they are packed in their magazine cases.

The Containers are flashproof and each holds a full charge. They protect the charge from flash, both when in its magazine case and during its passage to the gun. They must not be loaded into the gun.

The flashproof detachable lid is secured by a webbing harness and a quick release buckle; the joint between lid and body is rendered flashtight by a boxcloth skirt secured by a "garter" spring. Containers are bakelite varnished and fitted with lifting tapes; they are stoutly made but require careful handling and must not be dropped with a charge inside.

Boxcloth Wrappers. Plate 34.

142. The wrappers give protection similar to that afforded by Containers. They are supplied for Cartridges, B.L., for 8-inch guns, and may be introduced for larger calibres. They are removed in the handling room.

Cases, Cartridge (Clarkson's). Plate 34.

143. Clarkson's cases are supplied to hand-worked B.L. guns on transferable mountings for transporting cartridges between the magazine and the gun. They are also supplied for B.L. 8-inch and 15-inch turrets for secondary loading.

The cases are of Clarkson's material and are flashproof. Clarkson's material is cork with an outer covering of stout leather. The lid, in the form of a cap, is secured to the body by a leather hinge and fastening. Leather lifting beackets are fitted.

144-149.

CHAPTER VII

CARTRIDGES FOR Q.F. GUNS AND AIRCRAFT CATAPULTS

Q.F. CARTRIDGES. *Plate 3.*

150. The Charge for a Quick-firing (Q.F.) gun cartridge and its means of ignition are contained in a brass cartridge case.

Q.F. cartridges are used with (1) Separate Ammunition, and (2) Fixed Ammunition.

SEPARATE AMMUNITION. *Plate 3.*

151. The projectile and the cartridge are separate units. The filled cartridge case is called a Q.F. Cartridge, Filled, and consists of:—

- (i) Cartridge case.
- (ii) Charge (with or without tinfoil and with a gunpowder igniter if flashless).
- (iii) Primer.
- (iv) Lid.
- (v) Safety Clip (where fitted).

FIXED AMMUNITION. *Plate 3.*

152. The projectile is secured in the cartridge case. The complete round is called a Cartridge Q.F. Fixed, and consists of:—

- (i) Projectile and Fuze (or plug).
- (ii) Cartridge case.
- (iii) Charge (with tinfoil and with a gunpowder igniter if flashless).
- (iv) Primer.
- (v) Safety clip (where fitted).

If the projectile is fitted with an external tracer a paper cylinder is fitted round the tracer. Perforated wads formerly used are now obsolescent.

Note.—Certain marks of guns may fire both Separate and Fixed Ammunition. After using Separate Ammunition the gun chamber may become worn where the mouth of the case is usually positioned, forming a "pocket." If Fixed Ammunition is then fired from the gun, the front end of the case will expand into the pocket and cause a jam or difficulty in extraction. When the pocket becomes too deep the gun is sentenced, viz.: "▲ for use with Separate Loading Ammunition only."

CARTRIDGE CASES.

153. Cases of British manufacture are of brass and are tapered towards the mouth to assist loading and extraction. The flange at the base prevents the case from being forced too far into the gun chamber, and it also assists extraction. A screw-threaded primer hole is cut in the centre of the base. Cases are lacquered internally to prevent deterioration. Cases for certain American cartridges may be of steel.

Cases for Q.F. Cartridges 4.5-inch, 4.7-inch and 5.25-inch for separate ammunition are cannellured near the mouth to provide a better seating for the Cartridge lid.

Fixed Ammunition cases are longer than those for Separate Ammunition by the addition of the bottle-neck for securing the projectile.

The flanges of star shell cases filled with star shell charges are milled for identification at night. Cases of 2-pdr. sub-calibre, H.A. gun ammunition have one-half of the rim milled.

After firing, the primer is removed from the case and the case is cleaned with hot water and soda, thoroughly dried, treated with mineral jelly and in due course returned to an Armament Depot in its box. The primers should be similarly treated.

Cases may then be rectified, refilled, and used again, unless condemned through a defect appearing on firing or during the rectifying process. The history of fired and refilled cases is shown by markings stamped on the base (see Fig. 2).

THE CHARGE. *Plate 3.*

154. The methods of assembling the service charges for Q.F. cartridges vary considerably, being determined by the charge weight and the length of the cordite sticks.

CH. VII.

Charges for star shell, target smoke shell, special reduced practice, 3-pdr. and special Gunnery School charges are filled to a nominal weight; other Q.F. charges are usually filled to an adjusted charge weight. Filling to a fixed charge weight has been approved for certain guns.

155. Flashless charges (*para.* 36) are approved for both Separate and Fixed Ammunition. Cartridges with a cordite flashless charge are filled by the same methods as those filled with cordite S.C. Greater difficulty is experienced in igniting Flashless propellant and a gunpowder igniter in a worsted bag may be fitted in the centre of the bundle of cordite. A white cross on the base of the cartridge case denotes that the charge is flashless or non-blinding cordite. This marking is not used for star shell charges.

156. When using American propellant (*para.* 39) the grains are filled into the cartridge case loose. A cardboard cup is shellacked on top of the propellant and a cardboard distance piece is placed between the cup and the base of the shell to ensure that the grains are retained round the primer and to assist in keeping the charge compact. The same primers are used as for cordite S.C. A green bar on the base of the cartridge case denotes American propellant.

Tin foil.

157. Tin foil is fitted in Q.F. cartridges to prevent coppering of the bore of the gun. It is approved for all Q.F. ammunition except Separate Ammunition fitted with white metal lids which act as a substitute for tin foil.

To de-copper a badly coppered gun firing Separate Ammunition, additional tin foil may be thrown into the gun chamber between the projectile and the cartridge. If additional tin foil is required when firing Fixed Ammunition, cartridges specially made by the Armament Depot must be used.

Felt Wads.

158. Felt wads are obsolescent, but may be found in old types of cartridge; their function is to prevent movement of the charge away from the primer.

Lids, Q.F. Cartridge.

159. Cartridge case lids (except Bombardment Cartridges and Back Firing Target shell cartridges) are flanged corrugated discs of white metal, weakened by a number of radial slits; some types are perforated in the centre. Three or four notches are cut in the flange. The lid is secured in the case by bending over the tongues of the case into the notches. The joint between the case and its lid is sealed with R.D. cement. On firing, the white metal disc volatilises and the tin constituent acts as a decoppering agent.

160. A specially strengthened lid with four notches is used in cartridges for guns fitted with power ramming.

161. Future supplies of Q.F. cartridges may be fitted with plastic lids. In this event tin foil for decoppering purposes will be incorporated in the cartridge.

162. The lids for the Bombardment Cartridges (except 5.25-inch) and the Back Firing Target shell cartridges are leatherboard cups with becketts.

163. Early supplies of lids for use with tracer have their centres perforated. The perforation is covered with a disc of batiste (waterproofed cambric) and a paper disc is shellacked to the under side of the lid. The hole ensures a free passage from the charge to the tracer. This type is obsolescent.

164. All cartridge lids must be inspected before firing to ensure that they are well secured in their cases. The momentum of the charge while loading might force a loose lid into the chamber, and if the charge is separated from the primer a misfire or hangfire will result. For marking, see *para.* 188.

Safety Clips, Q.F. Cartridge. Plate 3.

165. Brass or steel safety clips are fitted to cartridges with percussion or combined electric and percussion primers as a protection from accidental blows which might fire the percussion cap. They must be removed before loading.

Safety clips are not fitted to cartridges for automatic guns nor to cartridges fitted with electric primers.

166. No. 12, Mark III and No. 25, Mark V are typical of the safety clips in supply.

- (1) No. 12, Mark III, is a dome with three arms which form spring clips. The arms fit over the flange of the case and secure the clip. The dome is positioned over the percussion cap.
- (2) No. 25, Mark V, is a dome with an outer circular disc. The disc has three prongs and a becket. The clip is secured in the base of a case by the prongs (in earlier Marks by press-studs) and the dome is positioned over the percussion cap. The becket assists the withdrawal of the clip. This type of clip is used with all cartridges which may be required to pass up pusher hoists, e.g., Q.F. 4-inch, Mark XVI*, 4.7-inch cases.

SPECIAL CHARGES FOR Q.F. CARTRIDGES

168. Q.F. cartridges are also supplied with the following types of charge :—

Reduced Charge.	Special Gunnery School Charge.
Star Shell Charge.	Clearing Charge.
Bombardment Charge.	

Reduced Charge.

169. Reduced charges are used mainly for bombardment with H.E., Smoke B.E., and Chemical B.E., and can be used for practice firings when authorised.

170. The full charge for Q.F. 5.25-inch guns consists of a reduced charge and an "Increment" or core which is fitted with a lifting band.

The conversion of 5.25-inch to a reduced charge must take place on the weather deck under cover, as follows :—

The case is placed on its base on a piece of felt on the flat wooden deck. The tangs at the mouth of the case are raised sufficiently (by a special tool) to allow the lid to be removed. The core increment is withdrawn by its lifting band and the lid is replaced so that the rim slots are in line with the tangs and the flange is in contact with the mouth. The tangs are then bent to their original position using a 12-oz. phosphor bronze or bronsteel hammer. The mouth of the case is gauged to ensure that the converted cartridge will load freely into the gun. The "gauge, cartridge, 5.25-inch, Mark 1," should go freely down until its level steel surface is either level with or below the mouth of the case; if the gauge will not go down, the distortion can normally be rectified by a few light taps with the 12-oz. hammer. (See Schedule of Implements, page 131.)

Star Shell Charge.

171. Special reduced flashless charges are supplied for firing star shell. Star shell for Q.F. 5.25-inch guns can be fired with a flashless Full Charge. Star Shell for firing with full charges are under design for all guns using separate loading ammunition (except Q.F. guns 4-inch Marks IV and V) and Q.F. 4.5-inch guns using fixed ammunition. When these shell are available they will use a fuze No. 215. As a means of identification at night the flanges of cases with star shell charges are milled.

Bombardment Charge *Plate 2.*

172. This type of charge may be used with certain Marks of Q.F. guns 4.7-inch and Q.F. 5.25-inch. The special reduced charge is designed to give shell a steep angle of descent at short ranges.

173. The Q.F. 4.7-inch, Marks IX, IX**B and XII, XII*B Bombardment Charge comprises :—

- (1) The Core or Portion No. 1.
- (2) Portion No. 2.
- (3) Portion No. 3.

174. The various charges are made up as follows :—

- Bombardment Charge No. 1.—The Core only.
- Bombardment Charge No. 2.—The Core and Portion No. 2.
- Bombardment Charge No. 3.—The Core and Portions Nos. 2 and 3.

The charge is supplied as Bombardment Charge No. 3, and is secured in the cartridge case by a leatherboard cup with a becket for its removal.

175. To adjust to Bombardment Charge No. 2.—Remove the leatherboard cup and withdraw the charge from the case. Unfasten the braid and remove Portion No. 3. Portion No. 2 and the core are tied together with the braid and replaced in the case. Care must be taken to see that the primer fits in the recess in the core. The case is closed by replacing the leatherboard cup.

To adjust to Bombardment Charge No. 1, the charge is withdrawn as above and Portions Nos. 2 and 3 are removed. The charge, consisting of the core only, is replaced in the case so that the primer fits in the recess and the case is closed by replacing the leatherboard cup.

The Portions removed in adjusting the charge are to be thrown overboard in deep water. When this is not possible, they are to be dealt with as directed by Article 42 of N.M. & E.R.

176. The Bombardment Charges for Q.F. guns 4.7-inch, Mark XI and 5.25-inch comprise the Core and Portion No. 2.

177. The charges are made up as follows :—

- Bombardment Charge No. 1.—The Core only.
- Bombardment Charge No. 2.—The Core and Portion No. 2.

The charge is supplied as Bombardment Charge No. 2.

178. To adjust to Bombardment Charge No. 1, the Portion No. 2 is removed and the Core is replaced in the case which is closed by replacing the leatherboard cup. The case for the Q.F. 5.25-inch Bombardment Charge is closed with the Service white metal lid, which must be removed and replaced in the same manner as when converting to the reduced charge for that gun (*para.* 170). The ties securing Portion No. 2 are dyed red.

179. The Service Reduced charge can also be used for bombardment in Q.F. guns 4.7-inch Mark XI and 5.25 inch.

CH. VII

180. To prevent the weight of the charge forcing the leatherboard cup out of the case, cartridges must be handled with great care at all times.

Shell must always be rammed home before loading the cartridge, and an improvised rammer must be used for the purpose. In no circumstances may shell be rammed home by means of the cartridge as this will damage the charge.

Special Gunnery School Charge.

181. For Gunnery School firing special reduced charges (less than normal reduced charges) are supplied; these may be made up with old cordite or cordite which is considered no longer suitable for Service.

Clearing Charge.

182. Clearing charges are at present supplied for Q.F. guns 4.5-inch; 4-inch U.S. 50 cal; 3-inch U.S. 50 cal; 3-inch U.S. 23 cal; 3-inch 20 cwt. (in Submarines); 2-pdr. Marks II*, II*C, and VIII; and 40 mm. (Bofors).

These charges provide a rapid means of clearing a gun firing Fixed Ammunition in the event of a projectile, jammed in the bore, being separated from its cartridge case on unloading.

Before using a Clearing Charge the gun chamber must be examined to ensure that no part of the cartridge case or charge has been left in the chamber.

On no account must the Clearing Charge be used as a blank cartridge.

183. Clearing charges—4.5-inch guns, a special cartridge with a shortened case and a reduced charge.

183A. For the U.S. guns, a shortened case and a full charge.

183B. For the 3-inch 20 cwt. guns, a shortened case and a full charge.

184. The Clearing Charge for the 2-pdr. guns has a shortened case. The charge is the normal full charge as a reduced charge would not produce proper functioning of the mechanism of the gun.

185. The Clearing Charge for the 40 mm. Bofors gun has a shortened case, but the charge is a reduced charge.

MARKINGS ON Q.F. FIXED AND SEPARATE AMMUNITION CARTRIDGE CASES**Stampings on Base of Cases.**

186. The following markings may be stamped on the base of Q.F. cartridge cases (Diagram 1) :—

- (i) Calibre and mark of gun.
- (ii) Mark numeral of empty case.

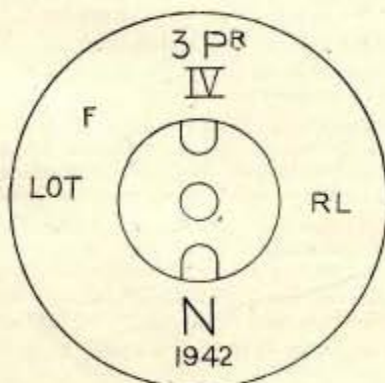
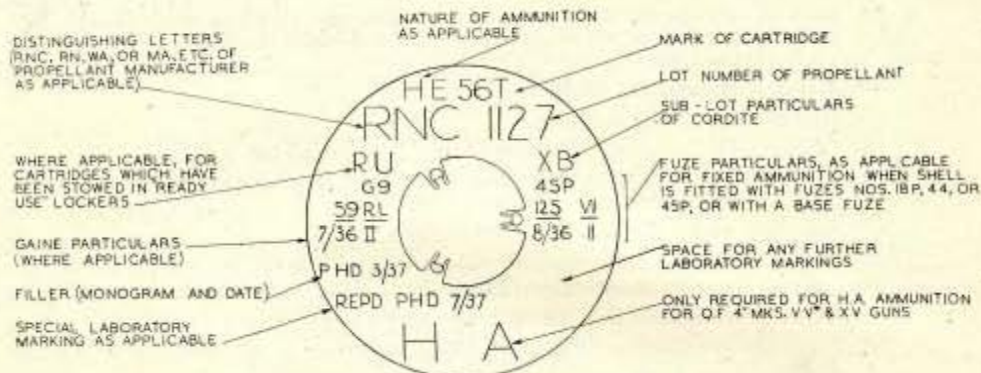

FIG. 1. STAMPINGS ON BASE OF Q.F. CARTRIDGE CASE.

- (iii) Year of manufacture.
- (iv) Trade Mark (or initials) of maker of the case.
- (v) Lot number of batch of cases.
- (vi) * following the mark of case denotes a conversion which advances the mark.
- (vii) ⬆ denotes that the case is accepted for service.
- (viii) N, denotes for Naval Service.
- (ix) G, denotes allocation to Gunnery Schools.

- (x) S following the mark of the case denotes repair by rebushing.
 (xi) Milled rims denote cartridges for star shell and drill.
 (xii) The words "DRILL" or "DRILL, PUSHER HOIST ONLY," where applicable.

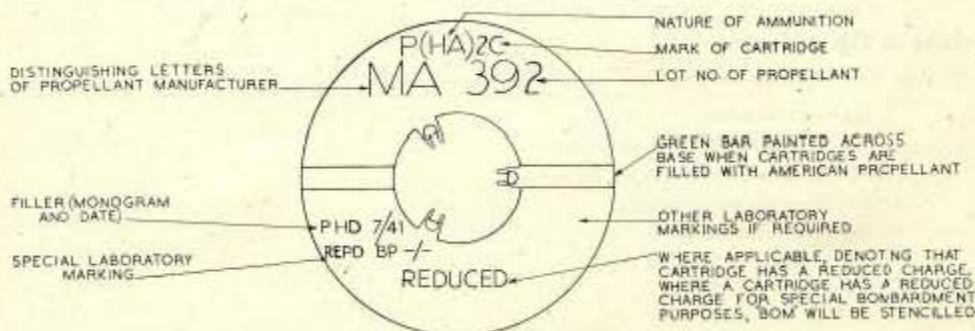
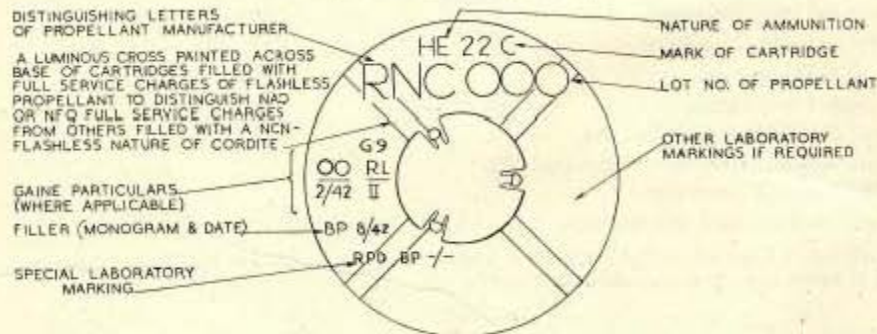

ARRANGED FOR F.A. WITH GAIN & FUZE

ARRANGED FOR SEPARATE AMMUNITION
(WITH AMERICAN PROPELLANT)ARRANGED FOR F.A. WITH GAIN & FUZE
(FULL SERVICE CHARGES OF FLASHLESS PROPELLANT)F.G. 2. CARTRIDGES, Q.F., (FIXED & SEPARATE) EXCEPT 2 PDR., 3 PDR., AND 6 PDR.,
TYPICAL ARRANGEMENTS OF STENCILLING ON CARTRIDGE BASES

CH. VII

Stencilling.

187. The following markings are stencilled in black across the base of Q.F. cartridge cases 12-pdr., 3-inch and above and on the side of the case for 6-pdr. and below. Markings are made with silver nitrate, black paint being permissible only when time is short :—

- (i) Distinguishing mark of cordite manufacturer, lot number of cordite, and sub-lot where applicable.
- (ii) Mark of cartridge (in Arabic numerals) on cartridges for Fixed Ammunition. This includes the type and, where applicable, a letter denoting the C.R.H. of the shell and " T " if tracer is fitted.
- (iii) Monogram or initials of the filling station.
- (iv) Date of filling (month and year).
- (v) " REDUCED " denoting " Reduced Charge," where applicable.
- (vi) The number of the G letter authorising the design, if the charge is made up to a sketch design for use in Gunnery School firings only.
- (vii) H.A. (high angle) as applicable on certain cases.
- (viii) Blank cartridge cases are stencilled " BLANK " on the base.
- (ix) " BOM " denotes a Bombardment Charge.
- (x) B.F. T.G.T. denotes a Back Firing Target Shell Charge.
- (xi) For Fixed Ammunition, Fuze and Gaine particulars as applicable. (See Fig. 2, diagram 1.)
- (xii) PAPER SHOT (if applicable).
- (xiii) Special Laboratory markings as applicable.

Marks on Lids of Cases.

188. The following markings are stamped on the lids of Q.F. cartridges :—

- (i) Mark numeral.
- (ii) N, denoting for Naval Service.
- (iii) \blacklozenge denoting acceptance for service.
- (iv) Manufacturer's initials.
- (v) Date of manufacture.
- (vi) Calibre and mark of gun.

CARTRIDGES FOR AIRCRAFT CATAPULTS. Plate 4.

189. Cartridges for Aircraft Catapults are made up on board on the weather deck under the instruction of the Directing Officer.

190. The cartridges consist of :—

- (i) Cartridge case.
- (ii) Cordite charge.
- (iii) Percussion primer (No. 10).
- (iv) Key for screwing in primer (No. 105).
- (v) Clip, Q.F. Cartridge.
- (vi) Shalloon braid securing tape.

Cases and Safety Clips are packed in a wooden box. Cordite charges (each in a cardboard container) are packed in metal cases (five containers in a case).

Cartridge Case.

191. Cartridge cases were formerly of brass, but are now of steel. They are designed on the same lines as Q.F. cartridge cases for Separate Ammunition with two slots cut diametrically opposite near the mouth. The two types of steel case are No. 1, Mark III (for a 6-inch cartridge) and No. 3, Mark III (for an 8-inch cartridge).

Cases may be used a number of times so long as their shape is maintained. After each shot with an 8-inch case a straight edge must be applied to the base to ensure that no convexity is present; if there is convexity it must be corrected before further use with a " Tool, reforming cartridge, catapult." This tool consists of a clamp piece (to engage under the rim of the case) and a pressure screw which is operated by a hand spanner.

The 6-inch case is a stronger type, and no tool is supplied.

Cordite Charge.

192. The charge is Cordite S.C./T. A ring of small cord Cordite S.C. or a bundle of Cordite S.S.C is used to assist ignition.

If a charge is removed from its cardboard container and is not fired it cannot be returned to the ship's magazine, but must be dealt with in accordance with Article 75 of Naval Cordite Regulations 1939.

Primer.

193. A No. 10 Percussion Primer is screwed into the primer hole with a special key (No. 105). The cap of the primer cannot be struck accidentally when the special key supplied for inserting and removing primers is used. (See Schedule of Keys, page 131.)

Safety Clip.

194. A safety clip, No. 25 Clip, Q.F. cartridge type, is fitted.

Method of Assembling.

195. The primer is screwed into the case and a Safety Clip is fitted. The propellant is removed from its container and inserted into the case with the cordite S.C. or Scroll next to the primer. It is secured by detaching the length of tape, reeving it through the slots in the case and knotting the ends taut in front. The cartridge is loaded and fired with the tape in place. The tape must be well secured to prevent the propellant moving forward against the baffle, as after one or two rounds have been fired the baffle is hot enough to cause a premature ignition of the charge if there should be contact. Cartridges should always be handled with the mouth inclined upwards.

196-204.

CHAPTER VIII
TUBES, VENT

GENERAL REMARKS

205. Tubes, Vent, are used in B.L. guns to ignite the gunpowder igniters of Cartridges, B.L., or the igniterless charges of B.L. guns 6-inch, Mark XXIII and 8-inch.

The tube fits into the tube chamber in the rear of the vent axial of the gun.

Q.F. cartridges fitted with a Tube and adapter are ignited by a Tube, Vent. (*Para. 223.*)

Tubes, vent, seal any escape of the propellant gases towards the rear through the vent (or adapter).

206. An escape of propellant gases would cause :—

- (i) Erosion of the vent.
- (ii) Inefficient sealing
- (iii) Difficulty in extraction of fired tubes.
- (iv) Damage to the lock of the gun.

Sealing is achieved by making the Tube a close but easy fit in the vent and by so designing it that, on firing, the front portion expands and seals any escape of gas between tube and vent. The internal arrangements prevent an escape of gas through the base of the tube and the lock or breech mechanism of the gun prevents the tube being forced to the rear.

207. On firing, a "flash" consisting largely of burning gunpowder pellets is shot from the magazine of the tube into the gunpowder igniter of the cartridge, or the igniterless cartridges of B.L. guns 6-inch, Mark XXIII and 8-inch, and the charge is ignited.

Electric Tubes are supplied in three sizes, .4-inch, .5-inch and 1-inch. For identification their flanges are plain and smooth.

Percussion Tubes are supplied in .4-inch and .5-inch sizes. For identification four notches are cut out of the flange.

Electric .5-inch Tubes for guns with strikerless locks are known as "S" tubes; they have a raised contact piece.

208. The greatest care in handling is necessary with each type of tube. Electric tubes can be rendered completely unserviceable by rough treatment. It is usual to test them with a megger before firing, and the electrical resistance should lie between 0.9 ohm and 1.1 ohm. Percussion tubes are liable to fire or become dangerous with rough treatment or shock.

The several sizes in each type of tube differ only in minor detail. To save repetition, the three types of the .5-inch tube will be described.

TYPES AND NATURES OF TUBES, VENT

TUBES, VENT, .5-INCH.

209. These Tubes are used as follows :—

- (i) B.L. 16-inch, Mark I gun has a strikerless lock and uses Electric S Tubes.
- (ii) B.L. 15-inch, Mark I has a strikerless lock and uses either Electric S Tubes or Percussion Tubes.
- (iii) All other B.L. guns have ordinary locks (except B.L. 6-inch, Marks VII, XI and XXIII and B.L. 8-inch) and use either Electric Tubes or Percussion Tubes.

Tube, Vent, Electric, .5-inch, Mark X. Plate 5.

210. The body is machined out internally to take the circuit and sealing devices. The internal arrangements include a gunpowder magazine, contact piece, ebonite insulating cup and bridge plug assembly. The bridge plug assembly comprises a copper plug, copper pole, central insulated copper wire and a bridge wire.

Action.

211. The tube is fired by passing electric current through the lock of the gun, contact being made between the striker of the lock and the contact piece of the tube. The current passes along the insulated copper wire and the bridge wire, and to earth by way of the tube body. When the bridge wire gets hot the priming of gun-cotton dust and the powder in the magazine are ignited; the resulting flash ignites the igniter of the Cartridge, B.L.

Escape of gas through the base of the tube is sealed by the bridge plug being forced rearwards, its base fitting into the small coned seating in the body; the gas-check on its forward end expands and helps the sealing.

Tube, Vent, Electric S, .5-inch, Marks VII and VIII. Plate 5.

212. The action of this tube is similar to that described above. The contact piece is "proud" of the base and is seated on a vulcanised paper washer when screwed into the ebonite cup.

Tube, Vent, Percussion, .5-inch, Mark VI. Plate 5.

213. The tube is machined out internally to take the cap holder and striker assembly. The internal arrangements include a gunpowder magazine, anvil, percussion cap, cap holder and the striker assembly. The striker assembly comprises a striker, striker sleeve, striker holder and hard brass shearing wire.

Action.

214. The tube is fired by the striker of the lock impinging on the striker of the tube. The striker of the tube is driven forward, breaks the shear wire, and fires the cap. The flash from the cap passes through the fire holes and the powder in the magazine is ignited. The resulting flash ignites the igniter of the Cartridge, B.L. The percussion cap is retained in place by the striker and striker holder and prevents the escape of gas through the base of the tube.

TUBES, VENT, 4-INCH.

215. This size of tube is used in B.L. guns 6-inch, Marks VII and XI. The percussion type is also supplied for Q.F. cartridges fitted with a Tube and Adapter.

Tube, Vent, Electric, 4-inch, Mark XII.

216. The tube is of similar construction to the .5-inch electric tube.

Tube, Vent, Percussion, 4-inch, Mark XI.

217. This tube does not contain a perforated pellet. The fire holes are sealed with whited brown paper.

TUBE, VENT, ELECTRIC, 1-INCH. Plate 5.

218. The tube is used with B.L. guns 6-inch, Mark XXIII and 8-inch. The flash produced is so intense that a gunpowder igniter is not required to ignite the Cartridge B.L. The tube is larger than, but in other respects is similar to, the .5-inch Electric Mark X. The front of the flange is square and not bevelled.

Mark IV is supplied. Marks I and III may be encountered, but they are obsolescent. No percussion tube of this size is manufactured.

Drill Tubes.

219. Tubes representing 4-inch and .5-inch Percussion Tubes and 1-inch Electric Tubes are supplied for drill purposes. They are identified by being blackened all over and having vertical indents in their bodies and milled bases.

The Electric Drill Tube has a metal contact piece and its mouth is closed by a wooden plug.

The Percussion Drill Tube has a recessed base which is filled with a hard rubber pad secured by a metal holder.

Markings.

220. The following markings will be found on the base of a tube :—

- (i) Letter "S," where applicable.
- (ii) Mark of tube.
- (iii) Manufacturer's initials or trade mark.
- (iv) Lot number.
- (v) Acceptance mark (A).

Packing of Tubes, Vent.

221. Tubes are packed in a flat tin box which is sealed by a soldered tear-off band. There are ten tubes in a box, and each box is labelled with details of its contents.

"Operation papers" are enclosed in each box of tubes and should always accompany a report of failure.

Tubes are stowed in a special locker in the Gunner's store room. Lockers are fitted near the guns for a ready-use supply of tubes in action.

CHAPTER IX

PRIMERS

223. Primers are fitted in Q.F. cartridges to ignite the charge. They are screwed into the primer hole of the case and form an integral part of the cartridge. Instead of the conventional primer, cartridges for the Q.F. guns 12-pdr. 12-cwt. and 4.7-inch, Mark V* may be fitted with an Adapter to take a .4-inch percussion tube and Igniter.

Primers for Aircraft Catapult Cartridges and Blank Cartridges "to be made up on board" are supplied in boxes. All other Q.F. cartridges are supplied fitted with primers.

The types of primer are—Electric, Percussion and the combined Electric and Percussion. Each class of primer is identified by a number, and the types and numbers at present are :—

Primers, Electric Q.F. Cartridge Nos. 13, 17, 22, 24, 32 and 35.

Primers, Percussion Q.F. Cartridge Nos. 1, 2, 5, 9, 10, 11, 12, 15, 16, 23, 26, 27 and 33.

Primers, Electric and Percussion Q.F. Cartridge Nos. 14 and 19.

The design and components of the Primers, as illustrated, are typical of each class.

Primers, Electric Q.F. Cartridge. Plate 6.

224. The Electric Primer is similar to the Percussion Primer, except that a bridge plug assembly is substituted for the cap, anvil and cone seal.

Electric primers differ from one another mainly in the size of the body and in the size and shape of the magazine.

The action of a typical Electric Primer on firing is :—

The striker makes contact with the contact piece, completing the circuit through the central insulated copper wire, bridge wire, copper pole and back to earth through the body. The bridge wire gets hot and in turn the gun-cotton dust, the gunpowder pellet and the powder magazine are ignited. The flash from the magazine passes through the flash holes and ignites the charge of the cartridge. Gun pressure is prevented from escaping to the rear by the sealing action of the bridge plug which, on setting back under pressure, seats more tightly in its recess.

Nos. 17, 22 and 24 may be repaired and refilled.

Primers, Percussion Q.F. Cartridge. Plate 6.

225. The Percussion Primer consists of a body which contains a cap, anvil, cone seal and screwed plug, and a powder magazine. The Body is flanged at the base and screw-threaded externally just above the flange. The two slots in the base are for the key. Magazines of the various primers differ in size and shape, and they may be secured to the front of or incorporated in the body.

226. The action of a typical Percussion Primer on firing is :—

The cap is ignited by the blow from the striker. Flash passes through the fire holes in the anvil, past the cone seal, through the fire holes in the screwed plug and ignites the powder in the magazine. The resulting flash passes through the flash holes and the charge of the cartridge is ignited. The pressure set up in the magazine forces the cone seal on to its seating and the cordite gases are thus prevented from escaping to the rear.

Nos. 1, 9, 10, 11 and 15 may be repaired and refilled.

Primers, Electric and Percussion Q.F. Cartridge. Plate 6.

227. The combined Electric and Percussion Primer may be fired by either method. The body and mechanism of No. 14 and No. 19 are similar, but No. 19 has a smaller magazine.

The action of a typical combined Electric and Percussion Primer is :—

Percussion firing.—On percussion from the striker the central pole and striker bridge are driven forward, shearing the three shear wires. The rim on the striker bridge drives the cap against the screwed anvil and the flash passes through the fire holes; in turn, the gun-cotton dust, gunpowder pellet and the powder in the magazine are ignited. Gun pressure is prevented from blowing back by a shoulder behind the striker setting down on a soft copper washer.

Electric firing.—The action of the primer is similar to that of the Electric Primer.

No. 14 may be repaired and refilled.

Markings on Primers.

228. (i) Serial number of primer.

(ii) Mark numeral of primer.

(iii) N, denoting Naval Service.

(iv) Initial or monogram of filling station or trade mark or initials of firm filling the primer.

- (v) Date of filling (month and year).
- (vi) Lot number of primer.
- (vii) Contractor's initials or recognised trade mark.

Note.—The use of acceptance marks is discontinued, but the former symbol \blacklozenge may be encountered.

229. If a repaired and refitted primer is used the existing marking is barred out and, after repair, the following markings are added :—

- (i) R or M after the mark numeral of primer.
- (ii) N, denoting Naval Service, if not already so marked.
- (iii) Contractor's initials or recognised trade mark of repairing firm.
- (iv) Month and year of repair.
- (v) Lot Number.
- (vi) Contractor's initials or recognised trade mark or monogram of station refilling.
- (vii) Month and year of refilling.

Tools and keys are dealt with in Schedule of Keys. (Page 131.)

Markings on Adapters.

230. The following marks are stamped on the base of an adapter :—

- (i) Mark numeral of adapter.
- (ii) N, denoting Naval Service.
- (iii) Manufacturer's initials.
- (iv) Date of manufacture (month and year).
- (v) Lot number.

Note.—The use of acceptance marks is discontinued, but the former symbol \blacklozenge may be encountered.

231-234.

CHAPTER X

BLANK CARTRIDGES

GENERAL.

235. Blank Cartridges are issued to saluting ships for saluting guns; in special circumstances they may be used for signalling purposes.

The main functions of Blank Cartridges are to produce a loud report and to create as much smoke as possible. They are used without a projectile. Cordite is unsuitable for blank charges because (1) it is smokeless, and (2) it will not give a sufficient report or burn completely without a projectile to tamp the charge.

Normally, the components for Q.F. Blank Cartridges are supplied for making up on board, but in certain small ships a proportion of the outfit is supplied made up.

Blank cartridges supplied to ships for guns other than saluting guns are made up by the Armament Depots.

236. B.L. Blank Cartridges consist of a gunpowder charge packed in a silk cloth or a cream serge bag with a shalloon bottom; the mouth of the bag is choked with doubled sewing silk. The cartridge is hooped by means of silk or shalloon braids passed through fairleads sewn to the bag.

237. Q.F. Blank Cartridges consist of a gunpowder charge packed in a silk cloth, cream serge or shalloon bag and contained in a Q.F. cartridge case. Early marks of Q.F. Blank cartridges have a felt jacket over the bag, but these are obsolete for future manufacture.

238. Q.F. Blank Cartridges are made up on board under the supervision of the Gunner in a place above the waterline.

The procedure is:—

- (i) Examine the cartridge case. It must be perfectly clean and dry and a correct fit in the gun chamber. Cases may be used a number of times provided they are clean, unsplit and fit into the gun chamber.
- (ii) Insert a primer (or a Tube Group for those 12-pdr., 12-cwt. cartridges so designed). If a percussion or an electric and percussion primer or tube group is used a Safety Clip must be fitted.
- (iii) Stand the case on its base.
- (iv) Insert the charge (with choked end up), wad and other components as required.
- (v) Place the metal guide ring or the ring inserting cup, as required, over the mouth of the case.
- (vi) Insert the leatherboard cup in the guide ring or the ring inserting cup as required; press home with the wooden drift in the manner indicated by the instructional label.

Note.—If difficulty is experienced with a 3-pdr. or 6-pdr. charge owing to tightness, it should be lightly rolled. The charge must be a tight fit in the case.

239. Cases are only to be filled as required. Cartridges made up and not required for immediate use should be returned to their boxes for restowage in the magazine (Article 262 N.M. & E.R.). Safety clips (if fitted) should first be replaced on the cases.

Before cartridge cases which have been filled on board are returned to a Naval Armament Depot, they must be emptied and the primers removed. Charges should be replaced in their metal-lined cases.

Q.F. BLANK CARTRIDGES.

Cartridges, Q.F., Blank, 4.7-inch, 4-inch and 3-inch 20-cwt. Plate 7.

240. The Service Q.F. cartridge case is used. The charge consists of L.G. or G.12 powder enclosed in a silk cloth or cream serge bag.

Cartridges with percussion or combined electric and percussion primers have the bottom of the bag closed with a shalloon disc. Those fitted with electric primers have the bottom closed with a pocket which fits over the primer magazine. The front end of the bag is closed by choking with sewing silk.

The charge is loaded into the bottom of the case and above it are placed a millboard wad, a split paper ring and a leatherboard cup. The cup is pressed into the split paper ring (with the drift supplied) and on to the wad above the charge and prevents the latter moving forward. The cup is further secured by shellacking.

The charge is ignited by an electric, percussion or combined electric and percussion primer as required.

Cartridges, Q.F., Blank, 4-inch, Marks V-V, XV, XVI and XVI*. Reduced Mark II. Plate 7.**

241. Ships carrying these guns are supplied with Blank Cartridges with a special reduced charge for saluting purposes.

The cartridge case is the service case with a brass sleeve secured to it by screws through the base. A reduced charge of 1 lb. is loaded into the sleeve and secured by a leatherboard cup.

Cartridges, Q.F., Blank, 3.7-inch Howitzer. Plate 7.

242. The Service cartridge case is used. The charge consists of 15 oz. of L.G. or G.12 powder in a silk cloth or cream serge bag. The bottom of the bag is closed by a shalloon disc.

The charge is prevented from moving forward by a glazed board lid, which is pressed into the mouth of the case; it is also shellacked to the bottom of the case.

The charge is ignited by a percussion primer.

Cartridge, Q.F., Blank, 12-pdr., 12-cwt. Plate 7.

243. The Service cartridge case is used. The charge consists of 1½ lbs. of blank L.G. or G.12 powder in a silk cloth or cream serge bag. The bag is choked similarly to the 4-inch Q.F. blank cartridge. The bottom of the bag is recessed to fit over a calico and paper dome, round whose neck the bag is choked with a drawstring. A shalloon igniter containing 8½ drms. of new blank F.G. or R.F.G.2 (G.20 or G.12) powder is secured to the top of the dome which fits over the adapter or primer. A felt wad is placed on top of the bag and the whole is retained in position by a leatherboard cup. The cup is pressed down hard on the felt wad and is secured by three dabs of shellac.

Cartridges, Q.F., Blank, 6-pdr. and 3-pdr. Plate 7.

244. A special Q.F. cartridge case is used and contains the charge of L.G. or G.12 powder in a shalloon bag.

Markings on Blank Cartridges and Charges.

245. B.L. blank cartridges.

On one side of the case are stencilled:—

- (i) Mark of cartridge.
- (ii) Contractor's initials or recognised trade mark.
- (iii) Nature of gun.
- (iv) Weight of charge.
- (v) Class of powder,

and on the other side:—

- (vi) N, denoting Naval Service.
- (vii) Initials of firm filling or monogram of filling station.
- (viii) Date of filling (year and month).

246. Q.F. blank cartridges.

On one side of the bag are stencilled:—

- (i) Mark of charge.
- (ii) Contractor's initials or recognised trade mark.
- (iii) Nature of gun.
- (iv) Weight of charge.
- (v) Class of powder,

and on the other side:—

- (vi) N, denoting Naval Service.
- (vii) Initials of filling firm or monogram of filling station.
- (viii) Date of filling (year and month).

The word "BLANK" is stamped or stencilled across the base of cartridge cases supplied for such use.

Packing.

247. B.L. Blank cartridges are supplied in M.L. cases.

Q.F. Blank cartridges.—Made up cartridges are supplied in Q.F. ammunition or cartridge boxes.

Q.F. Blank cartridges "to be made up on board."—The gunpowder charges are supplied in bulk in A rectangular or M.L. cases. Cartridge cases are supplied in Q.F. ammunition or cartridge boxes. Wads, leatherboard cups and filling pieces are supplied in wooden packing cases.

All cases containing gunpowder charges and cases containing empty Q.F. cartridge cases for making up blank cartridges are painted red.

248-249.

CHAPTER XI PROJECTILES

SECTION I—GENERAL REMARKS

250. Projectiles in use in the Service fall into three main groups :—

- (i) Piercing shell.
- (ii) High Explosive shell.
- (iii) Miscellaneous shell, including practice shot.

FACTORS INFLUENCING DESIGN

The design of all types of shell is influenced by the following factors :—

- Travel down the bore.
- Flight in the air.
- Effect desired at end of flight and damage to the target.

Travel down the Bore.

251. A projectile requires a strong base to withstand chamber pressure, and the walls must be thick enough to withstand the acceleration forces and side slap. The filling must not "set back" on acceleration. Projectiles for a given gun must be of approximately the same weight, so that they leave the bore with the same muzzle velocity.

Flight in the Air.

252. One of the principal forces which affect a projectile in flight is the resistance of the air.

It is necessary to reduce this resistance to the projectile to a minimum in order to obtain :—

- (i) The maximum range at any given elevation.
- (ii) The maximum striking energy at any given range.
- (iii) The shortest time of flight at any given range.
- (iv) The greatest danger space at any range.

Given the weight, diameter and muzzle velocity of a projectile, the principal factors affecting air resistance are the shape of the projectile and its steadiness.

The resistance offered to a shell by the air is affected by the shape of its head and of its base behind the driving band.

253. The chief factor affecting head resistance is the length of head and not the actual curvature. Experiments indicate that an ogival shape is superior to a conical. Lengths of head up to 8-calibre radius have been found effective in reducing air resistance if satisfactory steadiness can be obtained with such long shell. Where perforating qualities are required shell must have a comparatively blunt point, and this has led to the adoption of a ballistic cap for certain Piercing Shell.

Steadiness depends on the physical constants of the shell and on the amount of spin imparted by the rifling. A long shell, such as an H.E., requires a higher rate of spin than a relatively short shell, such as an A.P.C., and is liable to fail for accuracy in a worn gun at an earlier stage than the shorter shell, owing to loss of spin from the smoothing of its driving band.

NOMENCLATURE FOR DESCRIBING THE SHAPE OF HEAD.

254. The shape of the head is described as either of "n" c.r.h. or "n/m" c.r.h.

In the first case, the head is a true ogive, struck with a radius of "n" calibres with the centre in the plane containing the shoulder.

In the second case, the length from shoulder to tip is the same as the length of a true "n" c.r.h., but the head is struck with a radius of "m" calibres with the centre in a plane below the shoulder.

The modern shell (see Fig. 3) is designed so that the height CD (often referred to as the "ballistic length") is the governing factor in the shape of the head, the radius of the curve AED being of secondary importance.

Thus, true 3 c.r.h. would mean that arcs of 3 calibres radius are struck with their centres on the line AB produced.

3/6 c.r.h. would mean that the length CD was due to 3 calibres radius and the curve AFD was of 6 calibres radius.

3/∞ c.r.h. would mean that the length CD was due to 3 calibres radius and the head was conical, AGD being a straight line, is considered a curve of infinite radius.

This system of nomenclature was adopted to enable an exact definition of any shaped head to be given for design purposes.

255. Previously, shells were referred to by the calibre length of the main striking radius. This was of use only when the head was a true ogive. If the main radius, however, happened to be struck from a point below the line of shoulder AB, it might be anything up to infinity for any height CD. Thus, quoting the main radius gave no indication of the true shape of the head.

The system gives latitude in design to enable the contour of the shell and fuze to be made to coincide, since, having the c.r.h. required, the length CD can be determined; also, the length and breadth of the fuze being known, the curve AFD can be easily adjusted.

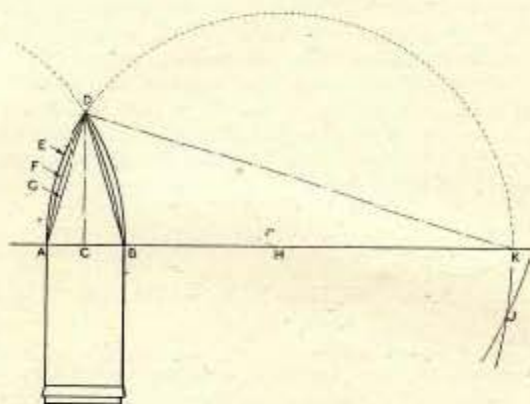

FIG. 3—SHAPE OF HEAD.

(All lines and points of reference to the right of a vertical through point A to be considered as having their complements symmetrically to the left of a vertical through point B.)

CD = Ballistic Length = L inches

AH = nd

AB = Calibre of Shell = d inches

AK = 2nd

$\frac{AH}{AB} = n$

AC = $\frac{d}{2}$

CK = $2nd - \frac{d}{2}$

AH = Radius of Curve E = n c.r.h.

AJ = " " " F = n/m c.r.h.

AD = (Straight line) " G = n/∞ c.r.h.

Formula to determine ballistic length.

256. Angles ADK and ACD are right angles and by similar triangles:—

$$\frac{L}{\frac{d}{2}} = \frac{2nd - \frac{d}{2}}{L}$$

$$\therefore L^2 = nd^2 - \frac{d^2}{4} = \frac{d^2}{4} (4n - 1)$$

$$\text{Hence } L = \frac{d}{2} \sqrt{4n - 1} = \text{Ballistic Length in inches.}$$

Thus for a 6-inch calibre—

The length CD for 2 c.r.h. = 7.94 inches.

" " CD " 4 c.r.h. = 11.62 "

" " CD " 6 c.r.h. = 14.39 "

Service Nomenclature.

257. Shell having heads of more than 2 c.r.h. are identified by the letters A, B, C or D after the Mark of the shell (*para.* 312).

For example:—

Mark III denotes a shell of 2 c.r.h. and under.

" IIIA " " over 2 c.r.h. and up to 4 (incl.)

" IIIB " " " 4 c.r.h. " " 6 "

" IIIC " " " 6 c.r.h. " " 8 "

" IIID " " " 8 c.r.h. " " 10 "

CH. XI—SECTION 2.

For shell with compound shape of head the procedure adopted for nomenclature is as follows :—

New designs of projectiles, if designed to range the same as an existing type, are given the same letter as that type. If, however, a new type is not designed to range with any existing Mark, its ballistic qualities are assessed with a view to giving it an equivalent or Service c.r.h.

It will be seen, therefore, that the nominal c.r.h. sometimes differs materially from the actual c.r.h., and it is dangerous to use the formula without ascertaining the true conditions.

Damaging the Target, etc.

258. Piercing projectiles are intended to perforate the side or deck of a ship and after a certain delay to burst inside, sending fragments sideways and forwards into its vitals. In addition, the detonation will produce blast which will damage light bulkheads and hatches.

In general, assuming uniform detonation, as the "capacity" of shell is increased so the size of the fragments become smaller and their velocity higher, while the blast effect gets greater. To produce maximum damage the capacity of the shell should be as great as the piercing requirements or the strength and length of the shell will permit.

CH. XI, SECTION 2—H. E. FILLING

CHIEF REQUIREMENTS

259. The chief requirements for a satisfactory high explosive filling are :—

- (i) That the explosive can be filled into the shell in a sufficiently dense form and in such a manner that cavitation does not take place and that the filling does not "set back" on acceleration of the shell.

A fairly high density of the filling is essential because, firstly, the detonation is more violent, and secondly, if the filling is not dense enough to prevent setting back on acceleration, prematures may occur with a sensitive filling such as lyddite. With less sensitive fillings the air gap left between the exploder system and the filling may decrease the intensity of the detonating wave and cause loss of power in the detonation.

- (ii) That the exploder system is suitable and will amplify the detonating wave initiated by the fuze sufficiently to detonate completely the main filling.

EXPLODERS.

259a. An exploder system is employed to amplify the impulse given by the fuze. This impulse may be Detonative, when provided by a fuze or gaine filled with C.E., or Ignitory, when a flash-giving fuze is used.

Exploders for Detonative Impulses.

260. In all detonating systems an impulse of sufficient intensity must be imparted to the main charge to ensure its complete detonation. A comparatively insensitive filling such as cast T.N.T. may be brought occasionally to complete detonation by the fuze alone, but some additional impulse is usually required.

The simple exploder consists of a bag or pellet of high explosive which augments the impulse given by the fuze or gaine. Exploders of this type are used when the main filling is one which is unlikely to "set back" when the shell is fired.

The exploder must remain in contact with the fuze as the detonation wave loses power rapidly in air. Any air gaps in the system of fuze, exploder and main filling are detrimental to the efficiency of the shell. To maintain contact between the fuze and the exploder the practice of compressing the exploder was adopted.

Exploders for Igniferous Impulses.

261. Base fuzes are mainly of the detonating type, but some of the igniferous type remain for use in small lyddite or powder filled shell. With the Igniferous type the exploder system is ignited and burns with an increasing degree of violence until explosion of main filling occurs. The time required to bring about explosion is such that the burst does not take place until the target has been penetrated. With igniferous fuzes in H.E. filled shell the exploder is normally picric powder.

METHODS OF FILLING.

262. The main filling explosives for Piercing and High Explosive shell are :—

- (i) T.N.T. either "Poured," "Block" or mixed with Beeswax.
 (ii) Shellite.
 (iii) Lyddite.
 (iv) R.D.X./B.W.X. R.D.X./T.N.T.

T.N.T.—Poured.

262a. Molten T.N.T. Grade I is poured into shell through the fuze holes (base or nose, as applicable) in three operations. On solidification the space between the top of the filling and the under side of the Base Adapter or fuze socket is filled in with beeswax composition (Kit composition) against which the top of the paper tube is pressed to form an effective seal. The shell is then fitted with an Exploder and fuze.

A gauge is used with base fuze shell to determine the number of glazed board discs to be inserted under the exploder; these ensure that, when the fuze is screwed home, there is sufficient compression on the Exploder to transmit its impulse satisfactorily to the Exploder and to the filling.

With base fuze and base and nose fuze shell, a copper gas check plate and a gas check cover plate and screwed ring are then fitted.

T.N.T. Block Filling.

263. This method of filling is used with certain base fuze shell. The blocks are made by pouring molten T.N.T. into hard grey paper containers. Two or more blocks are prepared for each shell according to its size and they are constructed to suit the cavity of the shell. After filling, the Base Adapter is then screwed home. T.N.T. adjusting discs are used to bring the exploder cavity to the required depth, and the shell is then fitted with its Exploder and fuze and closed in the same manner as with a "Poured" T.N.T.

T.N.T. Beeswax.

264. A mixture of T.N.T. and Beeswax is fed into the shell by a special screw filling process and the exploder cavity is then cut out. Other arrangements are similar to those for T.N.T. block and poured fillings.

Shellite and Lyddite.

265. The method of filling is similar to that for "Poured" T.N.T.

R.D.X/B.W.X.

266. The filling is pressed in place hot, formers being used to shape the cavities for the fuze and the Tracer and Igniter or Igniter.

R.D.X/T.N.T.

266a. This filling is pressed into the shell in a manner similar to T.N.T. "poured." It is sealed by a layer of pure T.N.T. to prevent interaction between the R.D.X. and the fuze arrangements.

CH. XI, SECTION 3—SPECIAL FEATURES

DRIVING BANDS. Fig. 4.

267. A Driving Band is a band or ring of soft metal attached to a projectile near its base.

Its functions are:—

- (i) To rotate the projectile.
- (ii) To centre the projectile in the bore.
- (iii) To prevent propellant gas escaping past the projectile.

As the projectile travels down the bore the driving edges of the lands exert pressure on and engrave the driving band and the projectile is rotated.

268. To give the maximum steadiness the band should be fitted as near to the base of the projectile as possible.

In practice this is limited by:—

- (i) The tendency for a band placed too near the base to cause eddy waves which affect ballistics.
- (ii) The tendency for a pressed-on band to tear off the metal behind it owing to the force of engraving; sufficient metal must be left in rear of the band to give the necessary shear strength.
- (iii) The necessity for the band being in front of the stream-lining.
- (iv) The necessity with Fixed Ammunition for the driving band to be far enough forward to allow the projectile to be firmly secured to the cartridge case.

Driving bands are usually of copper or copper alloys. Of these alloys cupro-nickel is used where a metal slightly tougher than copper is required. Bands are made of ductile material so that the material may be correctly displaced when the band is engraved. The material must be sufficiently strong to stand stress under the highest pressure in the gun and must offer, from round to round, a uniform resistance to engraving so that the ballistics of the gun are not affected. In addition, the design must provide for the displaced metal, otherwise this will be liable to project or fan irregularly from the band and cause variable resistance in flight and consequent inaccuracy.

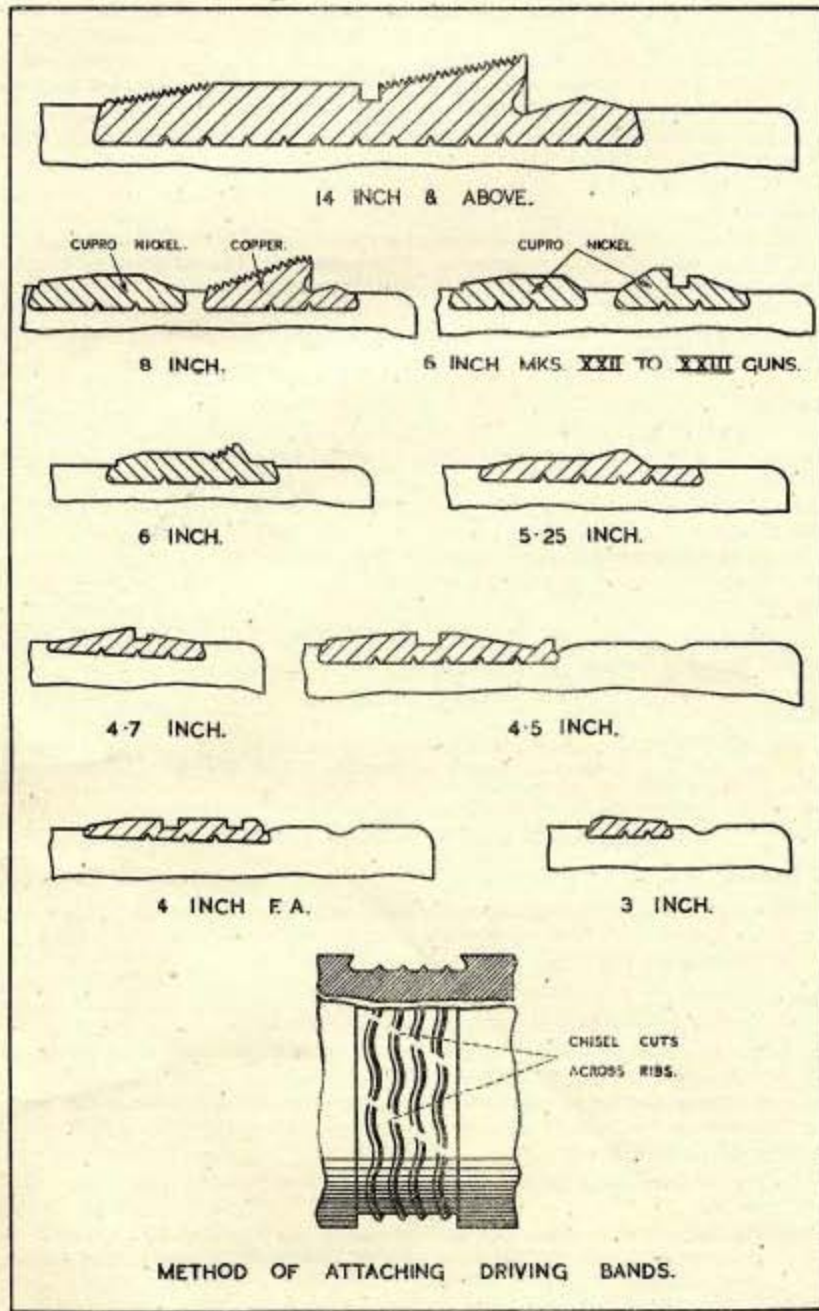

FIG 4.—TYPES OF DRIVING BANDS

The driving band is firmly attached to the projectile, being forced by a press into a groove round the shell. There are a number of waved ribs around the groove to prevent the band slipping round the shell; chisel cuts are made across these ribs to allow the air in the channels between the ribs to escape when the driving band is being pressed on.

269. Driving Bands fall broadly into two categories—the "Gas-Check" and the "Hump":—

(i) The gas-check band includes an undercut lip or second slope near the rear of the band, which is of a larger diameter than the remainder of the band. When the band travels forward and is compressed by the shot seating the lip is forced hard down on the metal in rear of it and prevents the escape of gas.

(ii) Hump bands are similar in shape but have no gas-check groove.

DOUBLE DRIVING BANDS

270. Higher velocities and pressures in modern guns have necessitated longer bands. These are made in two portions and are termed Double Driving bands. The bands are intended to overcome the mechanical difficulties of pressing a very wide single band on a shell. Double Driving bands have been introduced for shell for B.L. guns 6-inch, Mark XXIII and 8-inch.

When Separate Ammunition is loaded the highest part of the driving band takes against the coned shot seating of the gun, in some instances for a distance of $\frac{1}{4}$ -inch, and so brings the projectile to rest. No part of the driving band comes into contact with the rifling until the gun is fired.

With Fixed Ammunition, the driving band is a fraction of an inch clear of the shot seating of a new gun.

PENETRATIVE CAPS.

271. Steel Penetrative Caps are fitted to Armour Piercing and Common Pointed shell.

The cap is fitted over the nose of the projectile and is secured firmly to its head. Its function is to assist the break-up of the hard face of the plate and ensure that the head of the shell is not shattered.

Shell fitted with penetrative caps are referred to as "capped" and the letter "C" is added to their nomenclature, e.g., A.P.C., C.P.C.

Caps for A.P.C. shell are of hard steel and are intended to pulverise the hard face of the plate.

Caps for C.P.C. shell are of very soft steel and they support the point of the shell on impact.

BALLISTIC CAPS. *Plate 8*

272. Ballistic Caps are hollow thin steel domes, either ogival or conical, fitted to:—

(i) Piercing shell to increase their c.r.h. and so decrease the air resistance.

(ii) Practice projectiles fitted with the "K" device.

(iii) Practice projectiles fitted with the "A.K." device.

Ballistic caps are screwed and notched to the heads of the shell or their penetrative caps, and may be truncated or perforated for use with the "K" or "A.K." device.

Their light weight enables a long head to be used without adversely affecting the balance of the projectile and so the disadvantage of lengthening the actual head of the projectile to give a large c.r.h. is minimised.

Projectiles fitted with ballistic caps must be handled with special care to avoid distortion or loosening of the relatively weak cap.

"K" AND "A.K." DEVICES

273. The "K" or "A.K." devices are fitted to certain types of piercing shell and practice projectiles so that the firing ship may identify the fall of its own shot by the colour of the splashes. The outfit for a ship are all of the same colour.

"K" Device. *Plate 8.*

274. This device consists of a ballistic cap which has:—

(i) A suitable weight of coloured dyestuff. The colours supplied are red, yellow, green and white. White is an empty head without a filling.

(ii) A "K" adapter and a container with a C.E. pellet.

(iii) A percussion D.A. fuze No. 241 or No. 248.

The fuze functions on impact with the water, the device is exploded and the dyestuff colours the water.

275. The "K" device is fitted to:—

(i) 14-inch, 15-inch and 16-inch A.P.C. shell.

(ii) 8-inch S.A.P.C. shell.

(iii) 6-inch C.P.B.C. Heavy shell.

(iv) 14-inch, 15-inch and 16-inch Practice projectiles.

CH. XI—SECTION 3.

"A.K." Device. Plate 9.

276. The ballistic cap of this device is in two parts, the forward part being a removable cap. Coloured dyestuff is inserted in the ballistic cap. The removable cap has ports or apertures and is covered with a brass cap. The fixed part of the ballistic cap has ports which are fitted with brass plugs. On the fall of shot in the water action is initiated by the water entering the front ports and forcing the dyestuff through the rear ports. The effect is similar to that of the "K" device.

277. The "A.K." device is fitted to:—

- (i) 4.5-inch to 5.25-inch S.A.P. with ballistic caps.
- (ii) 8-inch and below Practice projectiles.

Filling Dyestuff or Changing Colour on Board.

278. "K" and "A.K." shell and Practice projectiles will normally be issued to ships in a condition for firing, but in case it is necessary to fill dyestuff or change colour on board, the following is the procedure:—

- (i) "K" device.
 - (a) Slack back fixing screw securing adapter or plug representing adapter.
 - (b) Unscrew adapter or plug representing adapter.
 - (c) Extract bags of dyestuff.
 - (d) Insert the requisite bags of dyestuff, tied together in line, taking care that sufficient space is left in the cap cavity for the lower part of the adapter when inserted.
 - (e) Replace adapter, using Mark VI luting to make an airtight joint between adapter and adapter seating on the end of the ballistic cap.
 - (f) Tighten fixing screw and cover hole with Mark VI luting.
- (ii) "A.K." device.
 - (a) Unscrew the front portion of the ballistic cap.
 - (b) Extract the bags of dyestuff.
 - (c) Insert new bags as required.
 - (d) Replace the front portion of the ballistic cap, using Mark VI luting on the threads.

The following notes are for the guidance of officers in charge of the work of inserting or changing the dye.

- (a) Enquiries indicate that the dyes used in this country are non-toxic. They are, however, in the form of a very fine dust and the inhaling of any dust for long periods is injurious.
- (b) The bags are treated to render them impervious to the dye, nevertheless, some escape must be expected. The position selected for the work should, therefore, be such that the draught moves from the operator to the shell and not vice versa.
- (c) Any rating who wishes to wear a face mask should apply for one to the Sick Bay. The wearing of such a mask is not generally necessary.
- (d) The dye will stain the skin and the stain cannot be removed in a single washing, but will come out gradually in the course of two or three days.

Note.—A small quantity of a patent stain remover is issued by armament depots when issuing a new colour. Instructions are on the tin, it can be used for removing stains on the skin on termination of the work.
- (e) Woollen clothing will be permanently stained, but the stains on cotton clothing can be washed out.
- (f) The men should wear overalls tied at the wrists.
- (g) Any rating suffering from or prone to an affection of the skin should not be employed inserting or changing the dye. Any rating who develops skin irritation while so employed should be immediately withdrawn from the work.

BASE ADAPTERS

279. The rear end of the cavity of base fuze shell is closed with a plug known as a base adapter. The adapter is screwed into the shell and the base fuze is screwed into the adapter. The base adapter is screwed into the shell anti-clockwise to prevent its being unscrewed by the rotation of the shell. The threads are coated with R.D. cement (except in block filled shell) to render them gastight and watertight; in most shell a copper washer is fitted under the flange of the adapter for the same purpose. In block filled shell the base adapter threads are coated with luting to facilitate unscrewing the base adapter if it is necessary to remove the filling ("Poured" filled shell can only be emptied by boiling out).

The original object of the base adapter was to assist manufacture of shell and facilitate the insertion of the container and the filling. In certain conditions it was found that on plate perforation by Piercing shell there was distortion of the shell base, base adapter, fuze and exploder system. For example, when a Piercing shell perforates armour plate obliquely the shell tends to straighten out, and in doing so its rear part swings round, strikes the lip of the hole in the plate and the shell base, base adapter and fuze may be broken off, even in less severe conditions the fuze may be damaged.

To provide for these possibilities the old solid plug type of base adapter has been superseded by the Relieved Base Adapter in Piercing Shell 8-inch to 15-inch.

280. In the Hadfield Relieved Base Adapter (*Plate 8*) the threads of the adapter are some distance in advance of the actual shell base. The inner ring is fitted behind the adapter to support the walls against the pressure of engraving the driving band. When a shell with this type of adapter perforates a plate the walls in rear of the adapter threads may be forced in, drawn to the rear or even wrenched off without affecting the action of the fuze.

There is another type of relieved base, similar in principle to the Hadfield design, whose walls are supported against the engraving pressure by a plate across the base instead of by the inner ring.

Either design may be encountered in 8-inch S.A.P.C. shell.

CH. XI, SECTION 4—PIERCING SHELL

GENERAL REMARKS.

281. Piercing shell are designed to perforate thick armour at battle ranges and, after perforation and a certain delay, to burst effectively, sending fragments sideways and forwards into the vitals of the target. The shell have thick heads and walls and so produce large fragments and a good forward effect. Their capacity is small.

Piercing shell are base fuzed. They are fitted with a detonative exploder system; an igniferous exploder system may be fitted in some shell of early types.

A copper gas check plate fits over the fuze and is held in position by a steel cover plate, or a No. 8 or No. 9 tracer secured by a screwed ring. Later Marks of large base fuzed shell are fitted with a guide ring to ensure that the cover plate or tracer does not turn when tightening up the screwed ring.

Where an Optional Delay Fuze is used its "setting" device is contained in the base cover plate of the shell or in the No. 8 tracer (if fitted). The types of setting device and their method of operating are set out in *para. 382*.

Armour-Piercing Capped (A.P.C.) Shell. *Plate 8.*

282. A.P.C. shell are of forged steel hardened (treated) to withstand the shock of impact and the various stresses imposed when perforating armour, especially at oblique angles. Shell are designed to perforate thick armour and, after a certain delay, to burst effectively; every consideration is subordinate to this end. Both a Penetrative Cap and a Ballistic Cap are fitted. The Penetrative Cap is sweated to the head of the shell and is additionally secured by its skirt, being pressed into notches formed on the ogival portion. Capacity is small so as to provide strength for penetration.

The cavity for the main filling is lined with an aluminium container. A cavity is left in the rear end of the filling into which one or more adjusting discs and the Exploder are fitted; the Exploder is under slight compression when the fuze is screwed in.

283. A.P.C. shell are supplied for 14-inch, 15-inch and 16-inch guns.

They are filled with Shellite except the earlier marks of 16-inch which are filled T.N.T. blocks. The capacity is about 2½ per cent.

The Exploder filling for a Shellite main filling is Picric acid; for a T.N.T. main filling it is T.N.T. or C.E.

Large base percussion fuzes Nos. 158, 158A or 159, are used. The fuze is screwed into the Base Adapter and pressed close against the Exploder pellet to ensure that the impulse is transmitted to the main filling.

Semi-Armour-Piercing Capped (S.A.P.C.) Shell. *Plate 8.*

284. S.A.P.C. shell are for use against lightly armoured ships. They are similar in design to A.P.C. shell, but their armour piercing properties are relatively inferior because of their greater capacity.

S.A.P.C. shell are supplied for 8-inch guns.

The filling is either Shellite with a Picric acid exploder or T.N.T./B.W.X. with a T.N.T. or C.E. exploder. In earlier marks the filling is T.N.T. "blocks" with a T.N.T. exploder. The capacity is about 5 per cent.

Large base percussion fuzes, Nos. 345 or 346, are used. If used with Tracer, a No. 8 Tracer is fitted.

Semi-Armour-Piercing (S.A.P.) Shell. *Plate 9.*

285. S.A.P. shell are either uncapped (monobloc) or fitted with a ballistic cap.

S.A.P. shell are supplied with Separate or Fixed ammunition for 12-pdr. 12-cwt.; 4-inch; 4.5-inch; 4.7-inch; 5.25-inch guns.

The filling is T.N.T. "poured" with a C.E. exploder; older types of filled Lyddite shell are still in the Service. The capacity is about 4 per cent.

T.N.T. filled shell are fitted with medium base fuzes Nos. 500 or 501. Lyddite filled shell are fitted with fuzes Nos. 12F Special or 500. If used with Tracer, a No. 9 Tracer is fitted.

CH. XI—SECTION 5.

Common Pointed Capped (C.P.C.) Shell.

286. Certain C.P.C. shell are used against unarmoured ships and light targets. The cap is of soft mild steel, and although this contributes to the perforating properties, the shell can only be relied upon to perforate thin armour and remain intact. Designed originally for powder filling, some shell have been converted to take T.N.T. "poured." The method of filling and exploder system are similar to those of A.P.C. shell.

C.P.C. shell are supplied for 6-inch and 15-inch guns. The capacity is about 7 per cent.

Large base percussion fuzes, Nos. 158, 159, 345, 346 or 480, are used according to calibre. This type of shell is obsolescent.

Common Pointed Ballistic Capped (C.P.B.C.) Shell. Plate 9.

287. C.P.B.C. shell are at present supplied for 6-inch and 14-inch guns; they are semi-armour piercing shell fitted with ballistic caps.

The filling is T.N.T. or T.N.T./B.W.X., dependent on the degree of insensitiveness required when attacking armour; some older types are Shellite filled. The method of filling and the exploder system are similar to those of A.P.C. shell. The capacity is from 4 to 6 per cent.

Large base percussion fuzes, No. 479 or 480, are used. If used with Tracer a No. 8 Tracer is fitted.

Common Pointed (C.P.) Shell.

288. C.P. shell are of cast or forged steel, unhardened. They were designed for 2-pdr. to 6-inch guns and are powder filled. C.P. shell are obsolescent.

The fuzes used are Hotchkiss, Nos. 12 or 15, according to calibre.

CH. XI, SECTION 5—HIGH EXPLOSIVE (H. E.) SHELL. Plate 10.

GENERAL REMARKS.

289. H.E. shell have a much higher capacity than Piercing Shell and are designed to cause damage by the force of their burst or by fragmentation. The maximum efficiency of a High Explosive shell is obtained only by its complete detonation. The degree of detonation or of explosion may be judged by the appearance of the burst and the colour of smoke produced. (*Para. 74.*)

High Explosive shell are of forged steel with walls and base in one piece. The material and the thickness of the walls have an important bearing on the efficiency of the shell. To obtain maximum capacity consistent with adequate strength the walls are tapered, becoming thicker towards the base. A shallow recess is bored out of the base and a steel Base Plate is screwed or caulked in to guard against the possibility of undetected flaws through which gases from the charge might escape on firing and ignite the main filling. The base plate is forged so that the grain goes across the plate and not through it; its diameter is approximately three-quarters of the calibre of the shell. High Explosive shell designed to take an internal No. 2 Tracer have a thicker base and a slightly reduced capacity.

The interior of the shell is copal varnished, to give a smooth surface and prevent corrosion of the steel by the filling.

The approved main filling for H.E. Shell of all calibres is R.D.X./T.N.T. Formerly the main fillings were T.N.T. or Lyddite. R.D.X./B.W.X. is approved for Q.F. 2-pdr. and 40 mm. (Bofors) H.E. Shell. (*Plate 11.*)

The Exploder system may be either Detonative or Igniferous, according to the filling and the fuze employed.

The fuze and exploder container are screwed into the nose of the shell. Some shell may be fitted with a nose bush. Exploder containers are used with shell 8-inch and above.

290. The majority of Q.F. High Angle shell are supplied plugged and fuzes are fitted on board. Shell taking Fuze No. 211 are supplied fuzed.

In High Angle H.E. shell a smoke box may be fitted below the exploder so that the burst may be more easily observed (*para. 99*). As a result of trials it is considered that the presence of a smoke box is unnecessary in medium calibre H.E. shell, and they are being omitted from future supplies in order to obtain some increase in lethal effect.

All H.E. shell are nose fuzed with the exception of certain Marks of 15-inch which are base and nose fuzed (B.N.F.). The selected fuze depends on the calibre of the shell and the service for which it is required; gaines are also fitted where necessary. 

In the event of 15-inch B.N.F. shell being used against targets which the common pointed shell were designed to attack, a special steel nose plug is supplied to replace Fuze 360. B.N.F. shell are fitted with a copper gas check plate which is held in place by a base cover plate and screwed ring. 

CH. XI, SECTION 6—OTHER PROJECTILES

Star Shell. Plate 12.

291. The function of a Star Shell is to illuminate a particular area or a definite target.

The forged steel shell is of the Base Ejection type and contains a parachute with an illuminating star attached. The shell walls are made to have the minimum strength consistent with their ability to withstand the pressure set up on discharge; this is to allow the maximum accommodation for the parachute and star. For Star Shell charges see (*para.* 171).

292. Star shell of the base ejection type are supplied for all guns 12-pdr. 12-cwt. to 5.25-inch.

Fuze No. 198 is used with shell 4-inch and below. Fuzes Nos. 206, 207 and 215 are used with shell 4.5-inch and above with certain exceptions. Future policy is to use No. 215 only, however.

Action.

293. The functioning of the fuze ignites the powder burster. The resulting explosion ignites the priming composition of the star, fractures the shearing pins and ejects the burning star and parachute from the base of the shell. The parachute opens out, rights itself, and allows the burning star to fall gently, open end downwards.

294. The use of Star Shell is limited to certain minimum ranges; below these ranges the strain imposed on the parachute by the high remaining velocity may cause fracture of its shrouds.

There are two types of parachute, the original type and a much stronger type recently introduced. Shell fitted with the original type are marked with a red star on a white disc. Shell containing the stronger type are marked with a green star on a white disc.

The following table shows, for each calibre and for each of the types of parachute, the minimum range for correct functioning with the present starshell charges. If fuzes are set to burst at shorter ranges, parachute failures are likely to occur.

The heights at which the shell should be set to burst are shown in the last column. These heights are selected to give the best illumination of the target consistent with the minimum dazzling of director crews, and are intended to cause the star to cease to burn when it has fallen to about 200 feet from the water. They differ in detail from the standard "2,000 feet height of burst" for which most ships have calculated the ranges to set on the range dials of the starshell guns and some revision of the "ranges to set" will be necessary.

EQUIPMENT	MINIMUM	DISTANCES	HEIGHT AT
	OLD TYPE PARACHUTE (RED STAR)	NEW TYPE PARACHUTE (GREEN STAR)	WHICH BURST SHOULD OCCUR
	Yards	Yards	Feet
Q.F., 5.25-in., Mark I	6,200	2,600	2,200
Q.F., 4.7-in., Mark XI	4,200	1,100	2,200
B.L., 4.7-in., Marks I* and II	1,800	1,000	2,200
Q.F., 4.7-in., Marks IX and XII			
Q.F., 4.7-in., Mark VIII	1,800	1,000	2,200
Q.F., 4.5-in., Marks I, III and IV	3,200	1,000	1,700
Q.F., 4-in., Mark XIX	1,000	1,000	1,700
Q.F., 4-in., Mark XVI	1,700	1,000	1,700
Q.F., 4-in., Marks IV, V and XII	1,000	—	1,700
Q.F., 3-in., 20-cwt.	1,000	—	1,200
Q.F., 12-pdr.	1,000	—	1,200

295. The approximate times of burning are :—

3-inch 20-cwt.	About 20 seconds.
4-inch	About 25 seconds.
4.5-inch	About 25 seconds.
4.7-inch	About 25 seconds.
5.25-inch	About 30 seconds.

Care must be taken to prevent distortion to the shell base and the shell must not be allowed to fall on its base. The access of water to the base should also be avoided.

CH. XI—SECTION 6.

Star Shell, 2-pdr.

296. This is a nose ejection Star Shell. It has an H.E. Shell body filled with a Star instead of high explosive. A dummy fuze is retained by weakened studs. A No. 1 or No. 3 Igniter is fitted and a burster pellet is superimposed.

Action.

297. The Igniter actuates the burster pellet. The resulting explosion ignites and ejects the Star through the nose of the shell. There is no parachute. With No. 1 Igniter the star is ejected at 3,000 yards. With a No. 3 Igniter the range is 5,000 yards. The time of burning of the star is about 4 seconds.

Smoke Shell, B.E., with a Time Fuze. Plate 12.

298. The function of these shell is to create an offensive or defensive smoke screen. The shell is of the base ejection type. The base is closed by a base plug which is either screwed in or secured by shearing pins. These shell are now obsolete.

The shell are in supply for Q.F. guns 4-inch, 4.5-inch, 4.7-inch and 5.25-inch.

Time fuze No. 198 is used.

Action.

299. The functioning of the fuze ignites the ejection charge. The resulting explosion ignites the containers, blows off the base plug and ejects the containers from the shell. The containers fall to the ground and emit smoke for about two minutes.

A fuze length setting should be used which will ensure that all shell burst and eject their containers in the air. The most suitable height of ejection is 2° 30' above the line of sight. Containers ejected from a shell at this height follow the trajectory of the shell body in their flight. With a trajectory that gives a lower angle of descent the containers tend to bounce. If a B.E. Smoke shell bursts and ejects on graze there is a possibility of the containers being buried and not emitting smoke.

Smoke Shell with a D.A. Fuze

299a. Shell to indicate the position of burst in bombardment are being designed. They will give a large and clearly visible burst of low persistence and will be fired with a full charge. Ranging and accuracy will be the same as the H.E. Shell with which they are to be fired.

Shrapnel Shell. Plate 12.

300. This shell has a forged steel body, lead antimony bullets embedded in resin, a central tube and a powder burster.

Time fuzes Nos. 93, 80, 400, 401 or 402 are used.

The shell walls are made to the minimum strength consistent with their ability to withstand the pressure set up on discharge so as to allow the maximum accommodation for the bullets which are kept in place by resin; the resin also provides more smoke for observation purposes. A powder burster in a tin cup fits into a recess in the base of the shell and is connected by a central tube to the fuze socket. The cup is intended to confine the powder which might explode on shock of discharge if it were loose and also be liable to get nipped between the disc and the shoulder.

Above the cup a steel disc rests on an annular shoulder formed in the interior of the shell to protect the cup from damage when the bullets set back on the shock of discharge. The central tube screws into the disc and one end fits into the mouth of the cup.

Action.

301. The explosion of the bursting charge blows off the head of the shell (which is only lightly attached to the body) and ejects the bullets. The velocity of these is chiefly due to the remaining velocity of the shell. The explosion sweeps the bullets, the head of the shell and the fuze clear of the body, and the bullets are spread out forwards in the form of a cone.

Target Smoke Shell.

302. This shell is made of steel and has a filling of phosphorus. It is fitted with a container having an exploder, a time fuze and gaine or a No. 211 fuze. On bursting, a white smoke cloud is formed in the sky and provides a target for anti-aircraft practice or assists in finding the direction and velocity of the wind. The shell are filled through a tapered hole in the shell wall which is closed by driving in a tapered steel plug. The exploder consists of a T.N.T. pellet in a steel container fitted under a nose fuze and gaine.

Target Smoke Shell are in supply for Q.F. guns, 3-inch 20-cwt., 4-inch, 4.5-inch, 4.7-inch and 5.25-inch.

The fuzes Nos. 198, 206, 207 and 401 are used with a No. 8, 9 or 10 gaine, except 3-inch 20-cwt. guns using the 124 lbs. shell which fit a fuze No. 185 with a No. 2 gaine. The No. 211 fuze is also used.

Chemical Shell.

303. B.L. and Q.F. Chemical Shell are described in the Addendum to this Handbook.

Practice Projectiles.

304. Practice Projectiles are made of iron or steel and may be solid or hollow. Service projectiles which have been condemned may be converted and used as Practice; they are emptied and brought up to weight by filling with inert matter of the same density as the original filling and plugged. Some Practice projectiles are supplied at "loading teachers" and should not be used for any other purpose.

High Angle Practice Projectiles are supplied for guns 8-inch and below. They may be converted H.E. shell, but shell manufactured as a separate store without a base plate and employing a modified design of cavity are preferable. The filling consists of powder and smoke pellets. The rear of the cavity may be filled with a wooden block. Projectiles use the same time fuzes as the corresponding H.E. Service shell. A number of the fuze hole threads are cut away so that when the shell filling is ignited the fuze may blow out easily, thus enabling the main shell body to continue forward unbroken. The puff of smoke indicates the position of burst.

Target Ship Practice Projectile.

305. Target Ship Practice Projectiles are designed to break up immediately on impact and to cause the minimum amount of damage. They are of steel and are hollow. For convenience in manufacture the nose may be closed with a conical shaped plug. The walls are weakened consistent with their ability to withstand the pressure set up on discharge and to assist breaking up on impact. Projectiles are not to be fired if any attempt has been made to eject them from a gun or if they appear to have been damaged by rough usage. The projectiles may be supplied for B.L. 8-inch guns for firing practice at Target Ships.

Proof Projectiles or Shot.

306. Proof Projectiles or Shot are made of steel and have the same weight as the corresponding service shell. They are usually solid, but they may be hollowed out and their length increased to achieve steadiness. They are flat nosed and cylindrical so as not to penetrate too far into the butt. Proof Projectiles or Shot are used at gun trials and at the butts for testing guns and for the determination of charge weights.

Paper Shot.

306A. These are used to test the mountings of guns, which cannot, owing to their position, fire service projectiles. The shell and charge are designed to cause the same amount of recoil as a service projectile and to break up on ejection.

Drill Shell.

307. Drill Shell are supplied for loading practice and as a rule represent H.E. shell. They are sometimes fitted with a nose bush having a 2-inch fuze hole and are issued plugged.

B.L. 8-inch Drill Shell are made of wood with a brass nose, base fittings and a strengthening bolt through the centre, and are much lighter than the Service shell.

B.L. 6-inch Drill Shell are made of wood and filled with lead; they have a brass nose, base fittings and a strengthening bolt through the centre. They are approximately the same weight as the Service shell. The Q.F. 4.7-inch Separate Ammunition Drill shell are designed on similar lines.

A type of Drill Shell has been introduced for some new equipments which is made of cast iron; it is of the same weight as its corresponding Service shell and has the contour of an H.E. shell with a Time fuze. The nose is shaped to clear the operation of the teeth of a fuze-setting machine; the shell is supplied for loading and fuze-setting drill.

The 3.7-inch Howitzer drill shell is a steel canvas covered drill shell.

Drill shell for pusher hoists are supplied for B.L. guns 6-inch and 8-inch. They are made of iron or are Practice projectiles specially supplied for the purpose; they are approximately the weight of the Service shell. Drill shell for pusher hoists are also supplied for Q.F. guns 4-inch and 4.7-inch.

308. Drill cartridges for Q.F. Fixed ammunition are supplied for loading drill. They are approximately the same weight and have the same outside dimensions as the Service shell. They are made of wood, have brass ends, and may also have brass bands; a strengthening bolt passes through the centre. The nose end of 3-inch and above has a 2-inch fuze hole to take a time fuze for practice setting.

Drill cartridges for Q.F. Fixed ammunition for special use in pusher hoists consist of an empty Q.F. cartridge case with a steel shell. A strengthening bolt passes through the centre of the case, one end screws into the base of the projectile and the other into the base of the case.

Dummy Shell.

309. Dummy shell are supplied for B.L. guns 15-inch and 16-inch for loading practice. They are made of wood, have a lead or cast iron core and are covered with raw hide. They weigh 340 lbs.

H. XI—SECTION 7.

CH. XI SECTION 7—MARKINGS ON PROJECTILES. *Plates 13 and 14.*

310. Projectiles are Marked, *i.e.*, Stamped, Coloured and Stencilled, as a means of identification. Projectiles 2-pdr. and above are at present marked in the following manner :—

- (i) The Manufacturer of the empty shell places on it certain STAMPINGS, and in some cases paints the shell the appropriate body colour.
- (ii) The filling contractor is usually responsible for :—
 - (a) Painting the shell with the appropriate colour, except where this has already been done.
 - (b) Painting the coloured bands, and
 - (c) The stencilling.

The colouring and stencilling are kept up to date by the Armament Depots as the projectiles pass through their hands from time to time.

311. Markings may be divided into :—

- (1) Stampings.
- (2) Colouring and Stencilling.

STAMPINGS

312. These refer to the empty shell. The type of shell or filling is sometimes shown by stamping so that in the event of the painting becoming obliterated the shell can be identified.

The positions of the stampings are :—

- (i) Projectiles used for Fixed Ammunition on the body above the driving band.
- (ii) Other projectiles, on the base.

The following stampings will be found :—

- (i) Calibre and mark numeral of shell. (How, if applicable.)
- (ii) Manufacturer's initials and lot number.
- (iii) Date of completion of manufacture.
- (iv) H. or L. denotes heavy or light shell, where applicable.
- (v) C.S., B.S., or F.S. denotes cast steel, bar steel or forged steel (for shell).
- (vi) C.I. denotes cast iron (for Practice projectiles).
- (vii) P denotes Practice.
 - A.P.C.—Armour-Piercing capped.
 - S.A.P.C.—Semi-armour-Piercing capped.
 - C.P.B.C.—Common pointed ballistic capped.
 - C.P.C.—Common pointed capped.
 - S.A.P.—Semi-armour-piercing.
 - S.M.K.—Target smoke shell.
 - S.M.K. B.E.—Smoke shell with base ejection.
 - CHEM.—Chemical shell.
 - CHEM. B.E.—Chemical shell with base ejection.

(viii) After mark of shell :—

A denotes over 2 c.r.h. and up to 4 (inch)	}	<i>See also para. 257.</i>
B " " 4 c.r.h. " " " 6 " "		
C " " 6 c.r.h. " " " 8 " "		
D " " 8 c.r.h. " " " 10 " "		

(ix) Q after the mark of shell denotes shell specially made to stand the pressure of the 6-inch, Mark XII gun. Shell for later high pressure guns, 6-inch, Marks XXII and XXIII do not have this letter.

(x) N.T. or T. denotes shell is fitted for tracer.

COLOURING AND STENCILLING.

313. Projectiles in supply are painted and stencilled as applicable to either of the methods illustrated in *Plate 14* where, for convenience, they are referred to as the "Old" method and the "Present" method.

Future policy is for a universal system of Markings for the Services. This standardised method is being determined by the Inter-Service Ammunition and Ammunition Package Marking Committee, and will be published in due course in a special pamphlet, *B.R. 1202*.

COLOURING.**The Bodies.**

314. The Bodies of projectiles are painted before they are filled, as follows :—

<i>Dull or H.E. Yellow</i>	Shell filled or suitable for filling with high explosive (which does not include gunpowder).
<i>Green</i>	Smoke Shell B.E.
<i>Grey</i>	Chemical Shell.
<i>Dull Yellow, top half ;</i>	}	Smoke Shell.
<i>Black, bottom half.</i>		
<i>Black</i>	All other projectiles, including those filled or suitable for filling with gunpowder.

Note.—Two shades of yellow are employed in shell painting :—

<i>Dull Yellow</i>	Denotes shell filled H.E.
<i>Bright or " Practice " Yellow</i>	Denotes that the shell is for practice purposes.

Points and Caps.

315. These are painted the same colour as the body except :—

Shrapnel shell	<i>Red.</i>
Shell filled Shellite	<i>Green.</i>
Shoulders of target Smoke Shell	<i>Dull (H.E.) Yellow.</i>

Bands round the Body of the Projectile.

316. *Note.*—Lyddite filled shell have only the red filling band.

<i>Red round head or shoulder</i>	Shell filled with explosive.
<i>Red above the Driving Band</i>	Shell fitted with live tracer.
<i>White above Red filling band</i>	S.A.P. or S.A.P.C. shell. <i>Note.</i> —Early S.A.P. shell have no White band.
<i>White ¼-inch wide on the body</i>	Centre of gravity for 15-inch shell.
<i>White 1-inch wide</i>	Position for grab on 16-inch shell.
<i>Green or Green and Black on the body or shoulder</i>	Shell filled T.N.T. or Head filled T.N.T. If a fraction such as 93/7 is shown above the green band, it denotes T.N.T./Beeswax; some shell may also have BWX stencilled in line with the fraction.
<i>Two Green with Practice Yellow between.</i>	H.E. special bombardment Practice. T.N.T. filling.
<i>Practice Yellow</i>	Practice Projectiles and Target Smoke Shell.
<i>Two practice Yellow</i>	Target ship practice.
<i>Blue</i>	Shell filled R.D.X./B.W.X.
<i>Blue with T.N.T. stencilled below band</i>	Shell filled R.D.X./T.N.T.
<i>Black zig-zag</i>	Radar.
<i>Black</i>	H.E. Drill shell.
<i>White zig-zag broken in three places with AR stencilled in the gaps. " ROPE " below the AR denotes the type of filling</i>	A.R. shell.

Shell Bases.

317. These are painted the same colour as the body. Fixed ammunition shell, filled lyddite, have the portion of the shell below the driving band and the base specially cleansed and finally painted green.

The colour of the *Gascheck Cover Plate* or *Disc Tracer* of base fuze shell and the *Screwed Ring*, which surrounds the cover plate, denote the fuze fitted :—

SCREWED RING	GASCHECK COVER PLATE OR DISC TRACER	DENOTES
Red	Red	Fuzes without delay action
White	Red	Fuze Nos. 158A, 159
White	Red with green bar	" " 158
Yellow	Red	" " 345A, 346
Yellow	Red with green bar	" " 345
Blue	Red	" " 479, 480
Blue	Red with green bar	" " 479
Red	Red with green bar	" " 500, 501
Red	Red with Yellow bar	" " 502
Red	Red with White bar	" " 551





CH. XI—SECTION 7.

STENCILLING. *Plate 14.*





318. The following general stencilling will be found where applicable on the cap, shoulder, body or base (during hostilities certain relaxations are allowed) :—

- (i) Calibre, with How, if applicable (not on 6-pdr. and below).
- (ii) K or AK and colour of dye.
- (iii) H or L or Weight, *e.g.*, 35 lb. (not on 6-pdr. and below).
- (iv) The mark of the shell, *i.e.*, type of shell, mark numeral, *c.r.h.* (*para.* 257), and T or N.T. if tracer is fitted. With Fixed Ammunition this is prefixed by the letters F.A. (not on 6-pdr. and below).
- (v) F Z D on shell (except Q.F. 2-pdr. and below) which are fuzed, serial number of fuze, Mark, date of filling, filled lot number and maker's initials. Projectiles 8-inch and above have these markings stencilled on the base as well as on the body.
- (vi) G on shell fitted with a gaine with the Number and Mark of gaine, date of filling, filling lot number, and manufacturer's initials.
- (vii) Monogram of filling station.
- (viii) Date of filling, month and year.
- (ix) L.G. or symbol as applicable on powder filled shell indicating nature of powder.
- (x) EXPL. BAG (or PEL.) on shell fitted with exploders with nature and size. Lot number of exploder if of P.P. or P.A. (picric powder or picric acid).
- (xi) On plugged shell for practice, the filling is indicated :—
 - SALT Salt.
 - P.S. Powder substitute.
 - (H.E.S.) H.E. substitute.
- (xii) N for Naval Service.
- (xiii) 70/30 or other fraction on Shell filled Shellite, T.N.T./Beeswax denotes the composition of the filling.
- (xiv) SMK BOX or " S " on GREEN DISC on H.E. Shell 6-inch and below denotes shell fitted with smoke composition in box.
- (xv) U on opposite sides of the head denotes fitted with Universal Cavity.
- (xvi) R denotes Radar.
- (xvii) L or S in the breaks of the zig-zag band denotes the use of Long or Short band Radar.

319. The following special stencillings may be found :—

- (i) 16 L.B. on 3-inch 16 lb. projectiles.
 - (ii)  in three places, on all 14-inch projectiles and above, indicates position of centre of gravity ; 15-inch projectiles have the horizontal lines extended round the body to assist in placing the grab ; 16-inch projectiles have a grab mark indicated in addition to the centre of gravity marking ; the grab marking consists of a 1-inch white band broken in three places equally spaced with the word GRAB stencilled in white in these spaces.
 - (iii) A on 3-pdr. and 6-pdr. indicates annealed shell.
 - (iv)  projectile prepared for tracer.
 - (v)  projectile fitted with night tracer.
 - (vi)  projectile fitted with Mark V or later tracer.
- The symbols in (iv), (v) and (vi) are applicable to shell fitted for or with Nos. 1 and 2 tracers.
- (vii)  projectile fitted with tracer.
 - number of tracer.
 - + mark of tracer.

320. The following markings are applicable to shell Q.F. 2-pdr. fitted with Igniter or Tracer and Igniter :—

- (i)  shell fitted with Igniter No. 1 Mk. I (long time to self-destruction).
- (ii)  shell fitted with Igniter No. 1 Mk. II (short time to self-destruction).
- (iii)  shell fitted with Tracer and Igniter No. 7 Mk. IV (with long time to self-destruction).
- (iv)  shell fitted with Tracer and Igniter No. 7 Mk. III (with short time to self-destruction).
- (v)  Projectiles Q.F. 2-pdr. filled for dark ignition tracer.

321. On *Star Shell* :—

- (i) A red star on a white disc.
- (ii) A green star on a white disc denotes a 27-inch Mark III parachute fitted.
- (iii) A letter and number or number below the disc denotes the star composition used.

CH. XI, SECTION 8—TRACERS. IGNITERS. TRACERS AND IGNITERS.

TRACERS, SHELL. *Plate 15.*

322. The tracer is fitted into the base of a projectile and its composition filling burns with a bright light to allow the flight to be observed.

Dark ignition tracers with a trace which is not evident until the projectile is some distance from the muzzle of the gun are in supply.

On firing shell fitted with a tracer the gases generated by the charge break down the brass sealing disc of the tracer and ignite the S.F. G2 powder. The tracer composition burns slowly during flight and produces a light sufficiently bright to be used by day as well as by night.

323. The types of tracers are :—

- (i) *The External Tracer*, which protrudes from the base of the shell and is only used with Fixed Ammunition projectiles:
- (ii) *The Internal Tracer*, which is used with Separate Ammunition projectiles and in some Fixed ammunition. (See also Plate 3.)
- (iii) *The Flat Base Tracer*, which is used with piercing shell with large base fuzes. It is also used with medium base fuzes in certain 5.25-inch shell and below.

Tracer, Shell, No. 1, Mark VI.

324. Tracer No. 1, Mark VI, is an external tracer whose cylindrical brass body is closed with a brass cap. The body of the tracer is bored and screw-threaded externally at each end, at the front to screw into the base of the shell, and at the rear to receive the cap. A hole is bored through the centre of the cap and closed by a brass sealing disc 0.005-inch thick sweated lightly over it. The filling consists of about 100 grains of composition S.R.247, which is pressed into the tracer body. At the cap end and on top of the composition four grains of S.R.247P composition are pressed with four grains of S.F.G.2 powder to serve as a priming composition. A space is left between the priming and the cap to form a gas chamber. This Tracer is used in Fixed Ammunition other than 2-pdr.

Mark VIA is now in supply. It is filled S.R.372 and gives a bright white to red light on firing. The burning time is somewhat shorter than with S.R.247.

Tracer, Shell, No. 13.

325. Tracer No. 13 has been developed to supersede Tracer No. 1. It is made of steel, and its filling consists of 34 grains of composition S.R.372 primed with 12 grains of composition S.R.399. It is used with Fixed Ammunition except 2-pdr.

Tracer, Shell, No. 2, Mark V.

326. No. 2, Mark V, is an internal tracer. The principal differences between this and the No. 1, Mark VI tracer are :—

- (i) The cap is screw-threaded externally and screws into the base of the shell.
- (ii) Both body and cap are made of steel.
- (iii) The filling is about 84 grains of composition.

Mark VA is now in supply. It is filled S.R.372 and gives a bright white to red light on firing. The burning time is somewhat shorter than with S.R.247.

Tracer, Shell, No. 16.

327. This tracer is an internal tracer for use with Separate or Fixed projectiles of all calibres prepared for it. The tracer should not be removed from the shell except on special instructions.

Tracer, Shell, No. 8 and No. 9.

328. These steel flat base tracers consist of a thick flanged disc. The disc has two drillings at right angles into which the composition (S.R.247) and the priming composition are pressed. A thin brass disc is inset in the rear of the tracer covering the tracer composition. The tracer composition channels are plugged after filing. The tracer is secured over the base fuze by a screwed ring. The tracer base forms the gas check cover plate over the fuze.

The difference between the No. 8 and No. 9 tracers is that No. 8 has the Delay Setting arrangement in the form of a removable screw in the base.

IGNITERS, SHELL.—TRACER AND IGNITER, SHELL

329. The Igniter is a device fitted in the base of 2-pdr. H.E. shell to ensure self-destruction of the shell if the fuze is not operated by a given time.

The Tracer and Igniter is a similar device combining the functions of tracer and self-destruction, and is fitted to 2-pdr. H.E. and 40 mm. H.E. shell.

Outfits for 2-pdr. are fitted with Igniter No. 1 and Tracer and Igniter No. 7, and the percentage is varied from time to time.

CH. XI—SECTION 8.

Outfits for 40 mm. H.E. shell are a 100 per cent. Tracer and Igniter, and either No. 7 or No. 14 may be fitted.

The design and filling of each device is such that, on firing, the composition is ignited either by the flash produced when the anvil strikes the cap on the shock of discharge, or direct from the flash of the cordite.

Igniter, Shell, No. 1. Plate 15.

330. Igniter No. 1 comprises a body (containing the ignition arrangements comprising an anvil, stirrup spring, cap-holder, cap and cap anvil), a pressed steel washer, a lead sealing disc, gunpowder, priming composition, igniting composition and a gunpowder pellet or loose gunpowder.

Action.

331. On the shock of discharge the cap-holder sets back, straightens out the stirrup spring, and carries the cap on to the central projection on the inside of the anvil. The cap composition is fired by the blow between this central projection and the cap anvil.

The resulting flash passes through the hole in the cap-holder to the gunpowder in the upper chamber. The firing of the cap blows out the lead sealing disc and the ignitory assembly, it also ignites the gunpowder, the priming composition, and the delay composition. When the delay composition has burned for the prescribed period, its flame penetrates through the hole in the pressed washer and ignites the gunpowder pellet or loose gunpowder. The flash is thus passed to the shell filling and explodes and destroys the shell 7-7½ secs. after firing.

Tracer and Igniter Shell, No. 7. Plate 15.

332. Tracer and Igniter No. 7 is similar in construction to the Igniter No. 1. The upper chamber is slightly larger in diameter and its method of functioning is more elaborate by the addition of the tracer composition. When the flame reaches the upper part of the tracer composition it ignites the gunpowder at the top of the body which in turn ignites the gunpowder pellet resulting in the explosion and break up of the shell. The time of burning is 7-7½ secs.

Tracer and Igniter Shell, No. 14

333. This Tracer and Igniter is an example of direct ignition from the flash of the charge. A heat relay unit is screwed on to the forward end of the body to improve the self-destruction arrangements. The tracer composition is retained at the rear end on a celluloid disc, which protects the powder but does not resist the flash from the charge. The time of burning is 12 secs. This Tracer and Igniter has been developed for the 40 mm. H.E. (Bofors) shell.

CHAPTER XII
SHELL FUZES AND GAINES

SECTION 1—GENERAL REMARKS

335. The detonation or explosion of the bursting charge of a shell is normally initiated by means of a fuze. Except in Fuzes Nos. 254 and 258 types, the detonation or explosion of a fuze is initiated by a pointed striker piercing a sensitive detonator.

TYPES OF FUZE

336. Fuzes are grouped into :—

- (i) *Percussion.*
- (ii) *Time.*
- (iii) *Time and Percussion.*

CLASSIFICATION

337. Fuzes are classified "Detonating" or "Igniferous" according to the type of explosive filling in their magazine.

The magazine of a Detonating fuze is filled with C.E. or Pentolite ; these fuzes initiate detonation.

The magazine of an Igniferous fuze is filled with powder and this type of fuze initiates explosion. Igniferous fuzes cannot by themselves initiate detonation, and if detonation is required a gaine is fitted. All Time (except No. 211), Time and Percussion and certain Percussion D.A. fuzes are igniferous.

SAFETY ARRANGEMENTS

338. Arrangements are embodied in fuzes and gaines to ensure that they are safe :—

- (i) During storage and transport.
- (ii) On the shock of discharge from the gun.
- (iii) During flight.

Arming.

338a. This is a mechanical event which is designed to take place as the shell leaves the muzzle of the gun. Before the fuze is armed it should not be capable of being put into operation by any rough usage or by any drop in any position which is likely to occur in the service.

As a rule, the moving parts of a fuze are securely locked together, and they can only be unlocked and the fuze "armed" by the particular combination of forces to which the fuze is subjected on project on from a rifled gun. No other combination of forces will arm the fuze, and the safety arrangements are in effect a combination lock to which firing from a rifled gun is the key. Mechanical locking and arming arrangements vary with the type of fuze.

Marking on Fuzes.

339. All empty fuzes are stamped :—

- (i) Number of fuze and mark.
- (ii) N for Naval Service.
- (iii) Contractor's initials or recognised trade mark.
- (iv) Date of manufacture.
- (v) Lot number of fuze.

When filled, the following information is added :—

- (vi) Initials of contractor or filling station.
- (vii) Date of filling.

The colouring of the cover plate and screwed ring is given in Chapter XI (para. 317).

DYNAMICAL FACTORS GOVERNING DESIGN

340. Four dynamical factors are available for the purpose of arming or actuating fuzes, namely :—

- (i) The rapid acceleration of the shell in the bore.
- (ii) Pressure of the propellant gases on the base of the shell.
- (iii) The rotation of the shell.
- (iv) The retardation due to impact.

CH. XII—SECTION 2

The Rapid Acceleration of the Shell in the Bore.

341. Under acceleration anything loose inside a fuze tends to set-back and this tendency is used with devices such as inertia pellets, arming-sleeves and detents to actuate or to arm fuzes. Pellets are small loose cylinders of metal (usually) holding the detonator or the striker. The force of set-back causes a lighting-pellet in a Time-fuze to fly back on to a needle and ignite the time ring of the fuze. Premature set-back may be prevented by a spring in the form of a stirrup or a helix. Pellets are used in Base fuzes to set-forward on impact. Detents are small bolts which fit longitudinally in a fuze as part of the locking arrangement: they are kept in place by a spiral spring.

Gas Pressure.

342. In the older type of Base fuze shell the pressure from the propellant gases is utilised to crush in a pressure plate which is usually attached to a spindle. The forward movement of the spindle unlocks the moving parts and arms the fuze.

In those modern base fuzes with a Delay Fitting, pressure from the propellant gases operates the pressure plate of the fuze to bring the Delay Fitting into operation.

The Rotation of the Shell.

343. Centrifugal force is utilised to withdraw safety bolts, open shutters, unwind tapes, or remove components necessary to arm the fuze.

The Retardation due to Impact.

344. Impact may be used to function a fuze by (1) causing pellets held back by creep springs to "set-forward" owing to their own inertia, or (2) crushing-in some portion of the fuze. The "set-forward" force due to the retardation of the shell caused by the resistance of the air must be provided for.

CH. XII—SECTION 2.—PERCUSSION FUZES

345. Percussion fuzes are classified:—

- (1) *Percussion, Direct Action or D.A.*
- (2) *Base Percussion.*

PERCUSSION, DIRECT ACTION

346. Percussion, D.A. fuzes are used with nose fuze H.E. shell intended to burst on impact.

A direct blow on the nose of the fuze forces the striker into the detonator and the resulting flash detonates the fuze magazine. These fuzes are usually fitted with a disruptive detonator (*see para. 469*). During flight there is a tendency for the hammer or needle to set-back and as this might operate the fuze prematurely the needle is held by a spring shearing wire or disc, or protected from air pressure by fitting a light cover over it.

347. Safety arrangements in these fuzes protect the head of the fuze prior to loading and seal the flash of the detonator from the magazine of the fuze should the detonator ignite or detonate prematurely.

Arrangements usually consist of:—

- (i) A metal cap (to be removed before loading).
- (ii) A shutter which opens under the action of centrifugal force set up by the rotation of the projectile. The shutter is held in position by a spring until the spring is overcome by centrifugal force.
- (iii) In certain fuzes, *i.e.*, 45P and 44, a safety pin is passed through the shutter to secure it. The safety pin is withdrawn before loading.

Fuze, Percussion, D.A.I., No. 45P (Powder Filled). Plate 16.

348. This fuze is for use with 12 pdr. to 6 inch H.E. shell.

The design and components of the Mark X fuze are shown in the illustration.

- *Note.*—This fuze and No. 44 are not interchangeable on account of the difference in the exploder systems of the shell in which they are fitted (*see also para. 479*).

Safety Arrangements.

349. The fuze embodies the following safety arrangements.

- (1) The steel hammer is protected by a bayoneted jointed cover and a safety cap. It is held clear of the detonator by a steel shearing pin.
- (2) The centrifugally operated safety shutter is held by a spring and a safety pin in such a position that it blocks the fire channel between the detonator and the magazine. A hole connects the space between the hammer and detonator with the space below the cap and provides a vent in case of accidental firing of the detonator.
- (3) During flight, the steel hammer is held clear of the detonator by the shearing pin.

Before Loading.

350. Immediately before loading the pin securing the cover is withdrawn to allow the cover and safety cap to be removed. The safety pin is attached to the safety cap by a becket and the removal of the cap pulls out the safety pin. In the event of the shell not being fired the safety pin and the cover with safety cap must be replaced and secured by the securing pin. If difficulty is encountered in replacing the safety pin the fuze must be returned to a Naval Armament Depot.

Action—On Firing.

351. The rotation of the projectile causes the safety shutter to swing against the pressure of its spring so that a hole comes into line with the central fire channel and detonator.

Action—On Impact.

352. The steel hammer is forced down; it shears the shearing pin and the striker is driven into the detonator. The resulting flash passes through the hole in the shutter and fires the fuze magazine.

Fuze, Percussion, D.A., with Cap, No. 44. Plate 16.

353. In the various Marks this fuze is used with 3-pdr. to 15-inch H.E. shell.

The design and components of the Mark X fuze are shown in the illustration.

The safety cap is secured to the body with a bayonet joint. The cap securing pin and safety pin are coupled together and secured to the cap with a whipcord becket. The cap securing pin passes through the cap to prevent it from being turned and accidentally removed. The safety pin passes through the cap and into the body to the shutter space and prevents the shutter from moving. (See note to para. 348.)

Safety Arrangements.

354. The fuze embodies the following safety arrangements:—

- (i) The striker needle is carried on a thin copper disc clear of the detonator and is protected by the safety cap.
- (ii) The centrifugally operated safety shutter is held by a spring and by the safety pin in such a position that it blocks the fire channel between the detonator and the magazine; the fire channel is filled with C.E.
- (iii) During flight, the needle is held clear of the detonator by the needle disc.

Before Loading.

355. The cap securing pin and safety pin are withdrawn and the safety cap is removed. The withdrawal of the safety pin frees the shutter. In the event of the shell not being fired the safety cap and pins must be replaced. If any difficulty is experienced the fuze should be carefully removed from the shell and thrown overboard.

Action—On Firing.

356. The rotation of the projectile causes the safety shutter to swing over against the pressure of its spring so that a hole comes into line with the central fire channel; the hole is filled with C.E.

Action—On Impact.

357. The needle disc is crushed inwards and the needle pierces the detonator. The resulting flash passes through the shutter and the fire channel to the fuze magazine.

Fuze, Percussion, D.A., No. 118. Plate 16.

358. This fuze is for use with:—

- (i) 3.7-inch, 14-inch, 15-inch and 16-inch H.E. shell.
- (ii) 6-inch (Mk. XII guns) Chemical Bursting shell.

The design and components of the fuze are shown in the illustration.

The fuze is similar to No. 230, but, as it has a larger magazine it is used without a gaine.

Fuze, Percussion, D.A., No. 230. Plate 16.

359. This fuze is for use with:—

- (i) Gaine Nos. 9 or 10 in 3-inch 20 cwt. to 8-inch H.E. shell.
- (ii) Gaine No. 11 in 4.5-inch, 4.7-inch (Marks IX, XI and XII guns), 5.25-inch and 8-inch Chemical Bursting shell.
- (iii) 4.7-inch Target Smoke shell.

The design and components of the fuze are shown in the illustration.

For instructions for fuzing and un-fuizing shell, see paras. 487, 489 and 490.

CH. XII—SECTION 2.

Safety Arrangements.

360. The fuze embodies the following safety arrangements :—

- (i) The striker, protected by a safety cap and striker cover, is held down before firing with its point in a hole in the shutter locking weight, in the position shown in the Plate. The shutter is thus held and, in consequence, the detonator is prevented from coming into line with the striker and the fire channel. The striker is held down by the striker sleeve which bears against the collar on the striker. The striker sleeve is held down by four loose segments fitted between it and the bottom of the guide bush. The segments are held in place by the arming sleeve which is kept up by an arming spring. The striker spring at the top of the striker is kept in compression while the fuze is in the "unarmed" state.
- (ii) Accidental ignition of the detonator will not ignite the magazine as the detonator is not in line with the fire channel. Should the detonator fire accidentally, the gases generated will pass up through the vent holes into the space round the arming spring.
- (iii) During flight, the striker is kept clear of the detonator by the striker spring. The striker head is protected from air pressure by the striker cover.

Before Loading.

361. The safety cap is removed and the striker cover, which must on no account be tampered with, is uncovered. In the event of the shell not being fired the safety cap must be replaced. If in the course of loading, the striker cover becomes dented or forced inwards, the fuze shell must be placed aside for un-fuzing. The damaged fuze should be returned to a Naval Armament Depot.

Action—On Firing.

362. The acceleration of the shell causes the arming sleeve to set back against its spring to a position clear of the four segments. Rotation of the projectile causes the segments to be flung out of position. This allows the striker spring, which has been in compression, to force the striker up, thereby withdrawing it clear of the shutter locking weight. Centrifugal force then swings the locking weight and shutter, thus bringing the detonator into line with the striker and flash channel. The fuze is now armed.

Action—On Impact.

363. The striker cover is crushed in. The striker is driven down and its point pierces the detonator. The resulting flash passes through the fire channel to the magazine.

Fuze, Percussion, D.A., No. 360C.

364. This fuze is used, without a gaine, under the mazak or zinc alloy cap of the 15-inch H.E. (B.N.F.) shell for bombardment purposes.

It is similar to the No. 118 fuze except that :—

- (i) The striker head is shaped differently.
- (ii) The fuze is fitted with a steel safety cap on manufacture; the cap is replaced by a light watertight cover when the fuze is screwed into the shell.

Fuze, Percussion, D.A., No. 241. Plate 17.

365. This fuze is for use with :—

- (1) 2-pdr. L.V., 3-pdr. and 6-pdr. H.E. shell.
- (2) The "K" device with 6-inch C.P.B.C. shell, and 8-inch S.A.P.C.

It supersedes No. 131 and No. 240. The design and components of the fuze are shown in the illustration.

Safety Arrangements.

366. The fuze embodies the following safety arrangements :—

- (i) The centrifugally operated safety shutter is held by a spring and a detent in such a position that it blocks the fire channel between the detonator and the magazine.
- (ii) During flight, the strength of the needle disc keeps the needle clear of the detonator.

Action—On Firing.

367. The inertia of the detent causes it to set back against its spring, thus freeing the shutter. The rotation of the projectile causes the detent to topple and lock back under the shoulder of the detent hole. The shutter swings open and its fire channel comes into line with the detonator and with the fire channel of the magazine.

Action—On Impact.

368. The needle is forced into the detonator. The resulting flash passes along the fire channel of the shutter to the fuze magazine.

Fuze, Percussion, D.A., No. 243.

369. This fuze is used with 2-pdr. H.V. H.E. shell. It has now been superseded by No. 246, to which it is similar except that the latter embodies delay arrangements.

Fuze, Percussion, D.A., No. 246. Plate 17.

370. This fuze supersedes No. 243 and is used with 2-pdr. H.E. shell in multiple H.V. close range equipments.

The design and components of the fuze are shown in the illustration.

Safety Arrangements.

371. The fuze embodies the following safety arrangements:—

- (i) The striker is held away from the detonator by half-collars, which are retained in position by the safety ferrule.
- (ii) The shutter blanks off the firing channel between the detonator and the magazine.

Action—On Firing.

372. The acceleration of the shell causes the arming ring to set back. This forces the safety ferrule over the detonator holder, thus releasing the half-collars. Centrifugal force then causes the half-collars to fly out leaving the striker supported only by the shear wire; and the shutter to swing open against the pressure of its spring. The hole in the shutter is thus brought into line with the detonator and the hole leading to the magazine. The fuze is now armed.

Action—On Impact.

372A. The disc in the nose is crushed in and the striker is forced down, shearing the shear wire. The point of the striker pierces the detonator and the resulting flash passes through the holes in the shutter and baffle to the delay ring and thence to the sleeve and magazine. The delay arrests the flash for a short time, causing the shell to burst at from two to six feet beyond the point of impact.

Fuze, Percussion, D.A., No. 248.

373. This fuze is for use with "K" device in shell 14-inch, 15-inch, 16-inch, A.P.C. or Practice projectiles. In addition, it may be fitted to "K" device shell approved to use Fuze No. 241. The safety arrangements and action are similar to Fuze No. 241, but it has a weaker creep spring.

Fuze, Percussion, D.A., No. 251.

374. This was the original fuze for the 40 m.m. H.E. shell (Bofors); it was superseded by No. 255 (described below) to which it is similar, except that the latter embodies delay arrangements. The safety arrangements and action are similar to those of No. 255.

Fuze, Percussion, D.A., No. 255. Plate 17.

375. This fuze supersedes No. 251, and is used for Q.F. 40 m.m. H.E. Shell (Bofors).

The design and components of the fuze are shown in the illustration.

Action—On Firing.

376. (i) The ferrule sets back on the shock of discharge and takes the stirrup spring with it. When the spring load exceeds the "set-back" force on the arming sleeve, the latter moves forward uncovering the two balls which fly outwards owing to centrifugal force. The striker and hammer are left free and are in the "armed" position.

(ii) On the shock of discharge the second ferrule also sets back on to a lead washer and takes its stirrup spring with it. The two parts of the shutter now separate and fly outwards under centrifugal force; this allows the detonator pellet, on the action of the spring, to move backwards and come into contact with the face of the stemmed plug. The detonator pellet is locked in this position by a pair of collars which, under centrifugal force, fly outwards into an annular groove in the body.

Action—On Impact.

377. The nose of the fuze is crushed in and the hammer drives the striker into the detonator. The resulting flash ignites the delay composition, the lead azide and the C.E. in the detonator pellet; the delay composition gives a short delay. The C.E. in the stemmed plug is ignited and detonates the C.E. or Pentolite in the fuze magazine.

Fuze, Percussion, D.A., No. 259.

378. This fuze supersedes Nos. 251 and 255 for use in Q.F. 40 m.m. H.E. Shell (Bofors). The contour is similar to fuze No. 255. The internal mechanism is a modified and improved version of the No. 246, and the safety arrangements and action are similar to No. 246.

CH. XII—SECTION 2.

BASE PERCUSSION

379. Base percussion fuzes are supplied to ships fitted in shell. These fuzes are designed in the following sizes, as follows:—

Hotchkiss	0.77-inch	} fuze holes.
Small	1.15-inch	
Medium	1.6-inch	
Large	2-inch	

Base percussion fuzes come into action when the forward velocity of the shell receives a sudden check instead of depending on a blow on the nose of the fuze. This involves the use of a comparatively heavy inertia (percussion) pellet carrying a detonator (or needle) loosely enclosed in a chamber, and capable of moving forward. The inertia pellet is prevented from making contact with the needle or detonator until the forces which come into play on firing unlock the mechanism which immobilises it. On impact the shell loses velocity, but the pellet, by reason of its inertia, continues on with negligible loss of velocity and the detonator strikes the needle; the resulting flash ignites the magazine of the fuze. The inertia control action produces a slight delay in the functioning.

380. Safety arrangements may consist of a shutter, centrifugal bolts, detents or pressure plates.

Premature ignition of the detonator during flight due to the "creeping action" of the pellet under deceleration is avoided by interposing a light creep spring in front of the pellet. The pellet must compress the creep spring before the needle can pierce the detonator and the strength of the creep spring is such that the pellet is retained on its seating until the forward movement of the shell is sufficiently checked. The greater the degree of sensitiveness required in a fuze, the lighter is the creep spring fitted.

Delay Fitting. Plate 18.

381. Certain large base percussion fuzes incorporate an optional Delay fitting (e.g., Nos. 158 and 159 types). When the fitting is used a delay is obtained in the functioning of the fuze and, thus, in the bursting of the shell.

Shell using fuzes with a Delay Fitting are set Delay or Non-Delay by means of a Setting Device in the base cover plate of the shell or No. 8 Tracer, covering the fuze.

When set to *Delay*, pressure from the propellant gases is admitted to the pocket in the base cover plate or No. 8 Tracer. The pressure acts on the copper gas check plate of the shell, which forces the pressure plate of the fuze forward, causing its tapered spindle to fit into a recess in the open side of the flash channel and the flash channel is thus blanked. When the percussion arrangements of the fuze function on impact, flash from the fuze detonator passes through the unobstructed flash channel to the Delay Fitting which arrests it for a short time before it reaches the fuze magazine.

When set *Non-Delay*, gas pressure is excluded from the pressure plate. On impact flash from the detonator reaches the ignition chamber by passing over the head of the pressure plate in the cross channel and thus avoids the delay fitting.

382. The types of setting device are:—

- (1) *A Setting Plug in the base cover plate of the shell.*—The plug is turned and set by Key No. 88. Directing arrows are engraved on the cover plate to indicate the method of setting.

To set *D (Delay)* the plug is turned in the direction indicated by the arrow until it is flush with the base cover plate and back against the stop screw.

To set to *N.D. (Non-Delay)* the plug is screwed hard home in the direction indicated by the arrow. When setting to *N.D.*, it is important that the setting plug is turned as far as possible in the direction indicated by the arrow, and that nothing other than Key No. 88 is used in the process.

When shell with this type of Setting Device are embarked the setting of the Plug should be checked by visual examination. When set *Delay* the chamfer of the plug is hard back against the stop screw. When set *Non-Delay* the plug intrudes about 1/10th inch into the cover plate and two to three threads are visible.

The functioning of *Non-Delay* arrangements in the fuzes will be impaired if alterations to the settings are made frequently, and these should be ordered as seldom as possible.

- (2) *A special gas-sealing Copper Screw in the base cover plate or No. 8 Tracer.* The key slot in the head of the copper screw is in the form of a square recess, and Key No. 150 is specially provided to insert or remove the screw. "For Delay Remove Screw" and a Directing arrow (corresponding to the right-hand threaded screw) are engraved on the cover plate.

When the requirement is *Delay* the screw is removed.

When the requirement is *Non-Delay* the screw is left screwed *HARD HOME*, or is re-inserted. Screws removed for the *Delay* setting should be carefully preserved for re-insertion when the requirement is *Non-Delay*.

Fuze, Percussion, Base, Hotchkiss, Mark IX. Plate 18.

383. This fuze is used in 3-pdr. and 6-pdr. pointed steel powder filled shell and also in 2-pdr. C.P. shell.

The design and components of the fuze are shown in the illustration.

The percussion pellet comprises a brass cylinder filled with lead alloy in which the needle holder and the needle are embedded. The needle holder and the percussion pellet cannot move and the creep spring is held in compression.

Safety Arrangements.

384. The fuze embodies the following safety arrangements :—

- (1) The needle holder is embedded firmly in the percussion pellet and the point of the needle is level with the top of the pellet. In this position the point of the needle cannot reach the detonator.
- (2) After firing and during flight, the needle is kept clear of the detonator by the creep spring.

Action—On Firing.

385. The shock of discharge causes the percussion pellet to set back over the needle holder. The alloy at the bottom of the pellet cushions against the bottom of the fuze and a portion of the alloy is dovetailed into the undercut recess. This forms a weak connection between the percussion pellet and the body and assists in checking rebound which otherwise might cause premature action. The creep spring expands and assists in holding the pellet back. The fuze is now armed.

Action—On Impact.

386. On impact the percussion pellet sets forward and overcomes the connection formed by the dovetailing of the alloy into the recess and the pressure exerted by the creep spring. On setting forward the percussion pellet carries with it the needle holder, and in consequence the needle pierces the detonator. The resulting flash passes through the flash hole in the cap and ignites the filling of the shell.

Note.—Owing to the small space available and because shell fuzed with different Lot Nos. may be supplied in the same box, the Lot Nos. of these fuzes are omitted from the marking of both the shell and the boxes which are marked "fuzed" only.

Fuze, Base, Percussion, Nos. 500, 501. (Plate 18) 502, and 551.

387. These "Medium" size detonating fuzes are all similar in design.

No. 501.

No. 501 fuze, which is illustrated in the Plate, embodies the principles employed in all Medium base fuzes, and its design and components are typical of the series.

This fuze is for use with 12-pdr. to 5.25-inch S.A.P. shell and supersedes No. 500.

No. 502.

No. 502 fuze is similar to No. 501, but has a weaker creep spring.

This fuze is for use with 4.5-inch, 4.7-inch (62 lb.) and 5.25-inch S.A.P. shell.

The base of the fuze is painted *Yellow*.

No. 551.

No. 551 fuze is similar to No. 501, but has a weaker creep spring.

This fuze is for use with 15-inch C.P. shell and 15-inch H.E., B.N.F. shell.

The Base of the fuze is painted *White*.

No. 551, Mark II is in supply and has a large magazine.

Safety Arrangements.

388. The fuzes embody the following safety arrangements :—

- (i) The inertia pellet holding the detonator is prevented from moving forward on to the needle by the upper and lower centrifugal bolts. The upper centrifugal bolt is held in position by the detent.
- (ii) In the event of the detonator firing accidentally before the fuze is armed the flash will not ignite the main filling as :—
 - (a) The flash hole in the inertia pellet is blanked by the masking bolt.
 - (b) The pellet seating on the base of the chamber forms a gastight joint.
 - (c) The sealing ball blanks off the flash hole in the body.

Action—On Firing.

389. Acceleration of the projectile causes the detent to set back against its spring; centrifugal force causes the detent to topple, locking itself back under the shoulder of the detent hole. The upper centrifugal bolt, the lower centrifugal bolt, together with the masking bolt and the sealing ball with its retaining bolt, fly outwards. The pellet is now held away from the needle by the creep spring only, and the flash channel is clear with the exception of the seating at the bottom of the pellet. The fuze is fully armed.

CH XII—SECTION 3.

Action—Impact.

390. The pellet is carried forward by its own inertia and, overcoming the creep spring, carries the detonator on to the needle. The coned front end of the pellet jams tightly in the narrowing entrance of the needle cap and prevents the pellet rebounding. The flash from the detonator passes along the flash channel of the pellet, past the masking bolt and into the bottom of the pellet chamber, the flash then passes the ball through the cross channel to the perforated powder pellet, and ignites the C.E. filling in the ignition chamber. The pressure and heat from the explosion of this pellet passes to the C.E. in the vertical channel and the C.E. pellet in the magazine.

Fuze, Percussion, Base, Nos. 159, 346 and 480. Plate 18.

391. These "Large" size detonating fuzes are all similar in design. Their main difference is the strength of the creep spring; fuzes used in the larger calibre shell have weaker creep springs. The fuzes incorporate the optional delay fitting whose setting devices are described in *para.* 382.

No. 480.

No. 480, which is illustrated in the Plate, embodies the principles employed in all large base fuzes and its design and components are typical of the series. No. 480 is used with 6-inch C.P.B.C. or C.P.C. shell and supersedes Nos. 479 and 479A.

No. 159.

No. 159 fuze is used with A.P.C. shell 8-inch and above and with 15-inch C.P.C. shell; it supersedes Nos. 158 and 158A.

No. 346.

No. 346 fuze is used with 8-inch S.A.P.C. shell; it supersedes Nos. 345 and 345A.

Safety Arrangements.

392. The fuzes embody the following safety arrangements:—

- (i) The inertia pellet holding the detonator is prevented from moving forward on to the needle by upper and lower centrifugal bolts; the upper centrifugal bolt is held in position by the detent.
- (ii) In the event of the detonator firing accidentally before the fuze is armed the flash will not ignite the main filling as:—
 - (a) The flash hole in the inertia pellet is blanked by the masking bolt.
 - (b) The pellet seating on the base of the chamber forms a gastight joint.
 - (c) The sealing ball blanks off the flash hole.

Action—On Firing.

393. Acceleration of the projectile causes the detent to set back against its spring; centrifugal force causes the detent to topple, locking itself back under the shoulder of the detent hole. The upper centrifugal bolt, the lower centrifugal bolt, together with the masking bolt and the sealing ball with its retaining bolt, fly outwards. The pellet is now held away from the needle by the creep spring only and the flash channel is clear with the exception of the seating at the bottom of the pellet. The fuze is fully armed.

Action—On Impact—Set "Delay."

394. The pellet is carried forward by its own inertia and, overcoming the creep spring, it drives the detonator on to the needle. The coned front end of the graze pellet jams tightly in the narrowing entrance of the needle cap and prevents the graze pellet rebounding. The flash from the detonator passes along the flash channel of the pellet and past the masking bolt into the bottom of the pellet chamber, along the open side of the cross channel to the delay fitting and thence to the perforated powder pellet and the ignition chamber. The pressure and heat from the explosion of the powder pellet passes through the small hole in the screwed plug and brings about the detonation of the C.E. in the vertical channel and the C.E. pellet in the magazine.

Action—On Impact—Set "Non-Delay."

395. On impact flash from the detonator reaches the ignition chamber by passing over the head of the pressure plate in the cross channel and thus avoids the delay fitting.

CH. XII—SECTION 3.—TIME FUZES

396. Time fuzes (except No. 402) can be set to function at a predetermined time after firing. These fuzes are classified:—

- (1) *Time Combustion or Powder Burning Fuzes.*
- (2) *Time Mechanical Fuzes.*

With Time fuzes the spaces between the rings (*i.e.*, between the cap and top ring and between the body and the bottom ring), set-screw holes, safety pin holes and the escape hole discs are covered

with "waterproof composition." It is essential that waterproofing should not be destroyed, as it enables the fuze to retain its serviceability. Instructions for dealing with any fuze whose water-tightness may have been impaired are given in N.M. & E.R.

TIME COMBUSTION

397. Time Combustion fuzes are illustrated in Plate 19. The fuzes consist essentially of a body containing an ignition arrangement, two rings (filled with fuze powder) surrounding a central stem and a magazine below the rings. The arrangement for igniting the fuze powder consists of a pellet which carries either a detonator or a needle. On firing, the pellet sets back and the needle pierces the detonator; the resulting flash ignites the fuze powder whose time of burning will have been regulated by the setting. When the correct length of fuze powder has burned, a flash is conveyed to the fuze magazine. The explosion of the magazine causes the shell to burst either by direct ignition of the shell filling or through the medium of a gaine.

398. Safety arrangements comprise:—

- (i) The needle and detonator are kept apart until the gun is fired. This is effected by holding the needle pellet and the detonator holder apart by a helical spring or a stirrup spring. In some fuzes a safety pin, to be removed before firing, is also provided.
- (ii) While the fuze is set to "SAFE" accidental ignition of the detonator will not ignite the fuze magazine, as the fire channel to the magazine is blanked by a solid portion on the bottom (revolving) ring. Ignition of the detonator will ignite the top ring which will burn out without igniting the bottom ring.

Fuze Powders.

399. The compositions filled into the annular grooves in the time rings are termed "Fuze Powders." They are usually ordinary fine grain gunpowder pressed into the rings under certain specified pressures to give a definite time of burning.

One ring is capable of being revolved on the fuze body so that the length of time of burning of the fuze powder may be varied. By this means the fuze may be set to burn for a fixed time.

400. Several classes of fuze powders are used in Naval Service and are distinguished by names indicative of the time taken by such powders to burn through No. 80 fuze rings or by numbers.

401. Powders in use are:—

- (i) *22 seconds powder*.—For time rings of No. 80/44 fuzes; also for the top rings of No. 192, No. 124 and No. 198 fuzes.
- (ii) *30 seconds powder*.—For the time rings of No. 181 and for the top rings of No. 93 fuzes.
- (iii) *R.D. 202*.—This is a long burning powder and is used for the bottom rings of No. 93, No. 124 and No. 198 fuzes.
- (iv) *S.R. 304*.—This is a short burning powder of good regularity and is used for filling the bottom rings of No. 400 fuzes (top ring has no filling).
- (v) *S.R. 227*.—This is a 25 seconds powder of good regularity and is used for filling both top and bottom rings of the latest Combustion type Time fuze.

402. Some fuzes (e.g., No. 93, whose lower ring is filled with R.D. 202 composition) are distinguished by having the lower ring coloured red.

With the exception of R.D. 202 compositions, the slower burning powders are more difficult to ignite than the faster burning powders; they are also more liable to stop burning during flight, especially when fired at high angles.

Both the rotational velocity of the shell and the attenuated pressures experienced at high altitudes affect the burning of fuze powders. The higher the spin and the greater the angle of elevation, the longer is the time of burning obtained. Both of these causes have the effect of increasing the difficulty of keeping the composition alight. Thus, it is necessary (especially for fuzes for the smaller guns and for high angle ammunition) to use (1) quick-burning powders which contain a comparatively low percentage of carbon in the charcoal used, or (2) a powder which is very hot burning. This is the present practice with No. 192 and No. 198 fuzes.

Composition R.D. 202 (in which length of burning has been achieved at the expense of accuracy) is adversely affected by the barometric conditions met with at high altitudes. With modern powerful A.A. guns at high quadrant elevation an occasional blind must therefore be expected.

Tensioning and Clamping.

403. In most fuzes the cap is screwed down so that the torque required to move the time ring lies within definite limits, and these fuzes are known as "tensioned fuzes."

In a few older fuzes the rings are tightly clamped in position. These fuzes are known as "clamping fuzes." To move and set the rings of clamping fuzes the top cap or nut must be eased up, the bottom ring moved to the required setting and the top cap or nut screwed down tight. Fuzes No. 181 and No. 93 are clamping fuzes.

The tensioning or clamping of the ring of Time fuzes ensures that the setting is not accidentally altered. It also guards against any movement of the rings when rotational velocity is imparted to

CH. XII—SECTION 3.

the shell by the rifling of the gun. If heavy vibration is experienced the setting of pre-set fuzes may alter. If pre-setting is essential the setting of such fuzes is to be checked at frequent intervals, and in any case after heavy vibration has occurred.

404. The tensioning of the time rings of combustion time fuzes may alter owing to varying climatic conditions :—

- (i) With normally tensioned fuzes, the tensioning may become either greater or less.
- (ii) With clamped fuzes the tensioning may decrease so that the time ring can be turned by normal application of fuze setting key. If fuzes are fired with comparatively loose time rings there will probably be irregular results or premature bursts.

405. Where the tensioning is less than the standard laid down in the next paragraph, the fuzes may be retensioned on board as described below.

The standard of tensioning to be maintained is :—

- (i) Fuzes as in para. 404 (i).—The time setting ring should require a firm pressure to set when using the hand fuze setting key. It should not be possible to turn the time setting ring with the finger and thumb.
- (ii) Fuzes as in para. 404 (ii).—With clamped fuzes it should not be possible to turn the time setting ring with reasonable pressure using the hand fuze setting key.

Instructions for increasing tension of fuzes, para. 404 (i) :—

- 406. (i) Ease back the two small set screws near the top a full turn each.
- (ii) Fit the key provided (key No. 133 for fuzes Nos. 198 and 400 or key No. 141 for fuzes No. 401).
- (iii) Hold the shell or fuze firmly and screw down the top of the fuze.
- (iv) Test the tension in accordance with the standard laid down and adjust if necessary.
- (v) Screw up the set screws.
- (vi) Set fuze to "safe" or setting ordered.
- (vii) Replace the waterproofing composition R.D.1154.

Instructions for damping fuzes, para. 404 (ii) :—

407. Similar action is taken when clamping fuzes to that laid down for increasing the tension, except that the fuze must be set to the correct setting before clamping hard down.

407A. Occasional checks on the tensioning of the combustion time fuze should be taken when carrying out inspections. It is not the policy to ease the tensioning of unclamped fuzes which are apparently stiff, as the stiffness may be due to damp having penetrated or corrosion being present in the time rings. Easing of tension in stiff fuzes may lead to premature bursts.

Fuze Setting.

408. The amount of fuze powder to be burned is regulated by the angle through which the bottom ring is turned. Graduations are cut on the body of the fuze to enable this angle to be read off and an arrow or line is cut on the exterior of the movable ring, or vice versa. The graduations on the body are arbitrary divisions chosen to obtain the requisite degree of fineness of setting; they do not necessarily represent minutes, degrees of arc or seconds of time.

409. Fuze scales are published to indicate the times of flight corresponding to the various settings.

The movement of the bottom time ring may be (i) by hand, using the suitable setting key; (ii) by a hand setter; (iii) by a fuze setting machine. Slots are formed in, or studs project from, the ring to enable it to be turned.

For hand setting with a key the position of the slots or studs is of little importance, as the ring is revolved until the graduation required appears opposite the arrow.

With some types of hand setter or fuze setting machine the position of the slots or studs must be accurate and care must be taken to avoid damaging or distorting them. On no account should they be used for any purpose other than setting the ring with the approved key, setter or machine.

Escape Holes.

410. In all Time fuzes (except No. 185) the time rings have radial exhaust channels or escape holes through which the gases generated may escape into the atmosphere. These escape holes are closed by escape hole discs. An efficient seal is essential to prevent direct access of burning gas at high pressure from the gun (which would cause a premature by flash over) and also to prevent moisture reaching the composition during storage. Prematures are occasionally experienced in sub-calibre guns with No. 124 fuzes, when flash from chamber gases enters the escape holes after the discs have blown off but before the projectile is clear of the parent gun.

Fuze, Time, No. 125. Plate 19.

411. This fuze is for use with 2-pdr. to 6-pdr. common nose fuze shell and has superseded No. 124; it is smaller than but similar in design and action to No. 198.

The flash channel between the detonator and the top ring is filled with mealed powder. This gives a slight delay in the lighting up of the top ring and is intended as a guarantee against the shell bursting in the parent gun when used in sub-calibre guns.

The bottom ring has ratchet teeth around its periphery to engage the automatic fuze setter. No cover is fitted.

The design and components of the fuze are shown in the illustration.

Safety Arrangements.

412. The fuze embodies the following safety arrangements :—

- (i) The detonator is carried in a pellet which is held clear of the striker needle by a stirrup spring housed inside the sleeve.
- (ii) Accidental ignition of the detonator will not ignite the magazine while the fuze is set "SAFE," as the flash holes in the rings are blanked in this position.

Before Firing.

413. The fuze is set by turning the bottom ring until the setting mark is in line with the required graduation on the upper ring.

Action—On Firing.

414. The inertia of the detonator pellet causes it to set back on to the needle which pierces the detonator. The resulting flash passes through the flash hole and ignites the composition in the top ring.

Action—During Flight.

415. The fuze powder in the top ring burns round until it ignites the powder pellet in the channel leading to the bottom ring. The fuze powder composition in the bottom ring is ignited and burns until it ignites the powder pellet at the head of the channel leading to the magazine. Escape holes are drilled in the time rings at the position where the train of powder is commenced. Each hole is filled with a perforated powder pellet and closed by a brass disc, which is blown out and allows the gases to escape as the powder burns.

Action—On Burst.

416. The flash passes along the channel and ignites the powder in the magazine. The flash from the magazine passes through the weakened portion in the centre of the closing plug and ignites the exploder.

Fuze, Time, No. 198. Plate 19.

417. This igniferous time fuze is of 2-inch gauge and is tensioned.

The fixed upper time ring is graduated 0—22. The movable lower time ring is engraved with the setting mark.

As an A.A. fuze No. 198 has been largely superseded by Nos. 206, 207 and 211 fuzes.

418. The fuze is for use with :—

- (i) 12-pdr. to 8-inch H.E. shell.
- (ii) 12-pdr. to 4-inch Star shell (except 4-inch Mark XVI).
- (iii) 4-inch to 5.25-inch Smoke shell B.E.
- (iv) 5.25-inch and 6-inch Chemical B.E. shell.
- (v) 4-inch, 4.7-inch and 5.25-inch Target Smoke shell.
- (vi) 12-pdr. to 8-inch H.A. Practice projectiles.
- (vii) 12-pdr. Falling Target shell.

The design and components of the fuze are shown in the illustration.

The screwed watertight cover must be removed before fitting fuze to shell; the cover may then be temporarily replaced.

Safety Arrangements.

419. The fuze embodies the following safety arrangements :—

- (i) The detonator in its holder is kept clear of the needle by a spring.
- (ii) Accidental ignition of the detonator will not ignite the magazine while the fuze is set "SAFE" as the flash holes in the rings are blanked.

Before Firing.

420. The cover is unscrewed and removed. The fuze is set by turning the bottom ring until its setting mark is in line with the required graduation on the top ring.

CH. XII—SECTION 3.

Action—On Firing.

421. The inertia of the detonator holder causes it to set back on to the needle which then pierces the detonator. The resulting flash passes through two flash holes and ignites the fuze powder in the top ring.

Action—During Flight.

422. The fuze powder in the top ring burns round until it ignites the powder pellet in the channel leading to the bottom ring. The fuze powder in the bottom ring is ignited and burns until it ignites the powder pellet at the head of the channel leading to the magazine. Escape holes are drilled in the time rings at the position where the train of powder is commenced. Each hole is filled with a perforated powder pellet and closed by a brass disc which is blown out and allows the gases to escape as the powder burns.

Action—On Burst.

423. Flash passes along the channel and ignites the powder in the magazine. The flash from the magazine passes through the weakened portion in the centre of the closing plug and ignites the exploder or detonates the gaine (where fitted).

The No. 198c is similar to No. 198, except that part of the screw thread which holds the fuze in the nose of the shell has been removed. The cutaway of the thread allows the fuze to blow out easily. No. 198c fuzes are used in certain H.A. Practice projectiles and these are stencilled appropriately.

Fuze, Time, No. 400.

424. This is a short burning fuze for use with :—

- (i) 12-pdr. to 16-inch H.E. shell (with a gaine).
- (ii) 4-inch and below (except 3.7-inch) Shrapnel shell.
- (iii) 12-pdr. to 8-inch H.A. Practice projectiles.

The body of the fuze and the safety arrangements are similar to those of No. 198, Mark II (Plate 19). Two additional flash channels are bored from the central space round the spring to the top time ring. The top time ring is empty, and flash from the detonator passes straight to the bottom ring which is filled with S.R.304 fuze powder.

The total time of burning of the fuze is 9 seconds. To distinguish this fuze from the No. 198, its lower ring is coloured with blue lacquer.

Fuze, Time, No. 402. Plate 19.

425. This fuze is for use with Shrapnel shell only in 12-pdr. H.A. and H.A./L.A., 3-inch 20-cwt. and 4-inch (Mark XIX) guns in D.E.M.S., Fast Liners and Oilers. The fuze must not be used with H.E. shell. The design and components of the fuze are shown in the illustration. The time of burning is fixed so that the shell is exploded at 500 yards range and no fuze-setting is required.

Safety Arrangements.

426. The detonator holder is held away from the striker needle by the spring.

Action—On Firing.

427. The detonator holder sets back against the spring and the needle pierces the detonator.

Action—During Flight.

428. The flash from the detonator passes through the flash channel and ignites the delay composition which causes a certain delay before igniting the powder pellet and magazine.

TIME, MECHANICAL

429. The mechanism of this type of fuze is designed to run at a predetermined rate after the fuze is armed. As the rate is little affected by the rotational velocity of the projectile in which it is fired, the time of running or time of burst is practically constant in any type of gun. The design is capable of being used in nearly all equipments, provided the time of flight is known, even though the range table does not include a scale for the actual fuze. The mechanical time fuzes in supply are Nos. 206, 207, 211 and 215; they differ only slightly in design.

Fuze Setting.

429a. Time Mechanical fuzes are intended to be set primarily by mechanical fuze setters, and the graduations provide a secondary means of setting by eye with a hand key.

The body or base piece is graduated externally from 00 to 21½. The lowest setting at which these fuzes will function is 007; with fuzes fitted with the muzzle safety bridge piece settings less than this will give blinds.

Fuzes are set by rotating the dome in a clockwise direction viewed from the point of the fuze.

430. The fuzes are issued set "safe" and must be in this condition before using the mechanical setter. If a fuze is disturbed from the "safe" setting, it must be carefully reset "safe" before it is set by a mechanical setter. Small reverse settings to adjust over-set fuzes may be made, but main setting must be in a clockwise direction only. Fuzes are not compromised by setting and may be reset a number of times if required. If heavy vibration is experienced, the setting of pre-set fuzes may alter. If pre-setting is essential the setting of such fuzes is to be checked at frequent intervals, and in any case after heavy vibration has occurred.

Although the most satisfactory setting is probably that done by the mechanical fuze setter, good setting to the graduations by hand key is possible if care is exercised. These graduations also form a rough check for the mechanical setter. Particular care is required when setting with a hand key. The key is marked with an arrow to indicate in which direction to rotate.

It is important to ensure that the fuze is still set "safe" after the removal of the cover, especially when it has once been set.

431. The safety arrangements are similar to those in Percussion D.A. fuzes, and differ fundamentally from Combustion Time fuzes as no detonator is struck on firing the gun.

432.

433. Consideration has been given to the use of time mechanical fuzes for bombardment, as this would simplify drill, and the supply of fuzes to ships taking part in assaults. Trials have shown that under easy conditions a time mechanical fuze will function on impact, but at small angles of descent or on soft ground there will probably be a high proportion of blinds. The shell burst is caused by the crushing in of the head and nose, thus firing the detonator of the fuze or gaine, and this train of action must entail a longer delay than when a direct action fuze is employed, whereas rapid initiation is most desirable for bombardment shell.

434. Whenever possible, direct action fuzes should be used for bombarding, but when the guns that are being used for bombardment must also be at immediate readiness to repel aircraft, the use of time mechanical fuzes is acceptable unless a large proportion of the target is soft ground.

For fuzing and unfuzing shell, (*see paras. 487 and 488*).

X Fuze, Time, No. 206.

435. This fuze is for use with:—

- (i) 4-inch to 8-inch H.E. shell (with No. 9 or No. 10 gaine).
- (ii) 4.5-inch to 5.25-inch Star shell.
- (iii) 5.25-inch and below Target Smoke shell.
- (iv) 4-inch to 8-inch H.A. Practice projectiles.

Some difficulty may be experienced on removing fuzes supplied in the cylinders No. 202. Should this occur and the fuze cover become unscrewed from the fuze, the fuze itself must be unscrewed from the cylinder by means of the fuze fixing key.

The mechanism is similar to that of the No. 211 fuze (*Plate 20*).

On impact with thin steel plating fuze No. 206 with a No. 9 gaine will also detonate the shell. At short ranges the gaine detonator will be actuated by the crushing in of the fuze body, even if the fuzes are set "SAFE": at longer ranges or at oblique impact it is desirable that fuzes should be set to burst well beyond the target.

For instructions for fuzing and unfuzing shell, *see para. 487*.

Safety Arrangements.

436. The fuze embodies the following safety arrangements —

- (i) The striker is kept away from the detonator by a cam-shaped foot which rests on a pillar. Should any fault in the mechanism allow the foot to come off the pillar before the fuze is rotated, further movement of the striker towards the detonator is arrested by the centrifugal safety catch which engages the foot and becomes locked. Subsequent rotation of the fuze will not free this lock, and a fuze fired in this condition will be blind.
- (ii) During flight, the centrifugal safety catch opens and does not interfere with the striker which is released after the passage of the "SET" time.
- (iii) The clockwork mechanism cannot be started when the fuze is set "SAFE," as the trigger safety catch prevents the trigger from setting back and freeing the hand. As long as the fuze is set "SAFE" the trigger safety catch is retained under the trigger by a stud which projects from the inside of the dome.

CH. XII—SECTION 3.

- (iv) *No. 206 Mark II* fuzes have been introduced into the service and have a device consisting of a bridge piece which prevents the hand of the clockwork mechanism from rising until the mechanism of the fuze has run approximately one second. This prevents premature bursts occurring just inside the muzzle of the gun.

Before Loading.

437. The watertight cap is unscrewed and removed. The dome is set to the required fuze length. This operation shears the dome shearing pin and also allows the trigger safety catch to come out from underneath the trigger.

Action—On Firing.

438. (i) The locking ring sets back, shearing the small rivets by which it is held, and its bottom edge is cut into by the locking pins in the base piece. As the locking ring is keyed to the dome any further turning of the dome relative to the base piece is prevented.
- (ii) The trigger sets back and frees the hand thus allowing the mechanism to start. The hand revolves anti-clockwise, and the hand spring continues to force it against the underside of the hand race.
- (iii) The rotation of the projectile causes the centrifugal safety catch to swing out clear of the cam on the striker.

Action—During Flight and on Burst.

439. The hand revolves until it comes in line with the gate in the hand race. The hand spring forces the hand through the gate and the end of the striker lever is released. This allows the striker to turn so that its foot drops off the pillar. The striker spring forces the striker down so that its point pierces the detonator. Flash from the detonator ignites the powder in the magazine.

Fuze, Time, No. 207.

440. This fuze is for use with the same shell as No. 206 fuze and also with 4-inch, Mark XVI, and 4.5-inch to 5.25-inch Star shell, and 4.5-inch and 4.7-inch Chemical B.E.

The fuze was introduced as a strengthened form of No. 206, but is now being superseded by No. 211 for H.E. shell.

The *Safety Arrangements* and action are identical to those of No. 206. The Mark III design is fitted with a bridge piece, which prevents the hand of the clockwork mechanism from rising until the mechanism of the fuze has run approximately one second. This prevents premature bursts occurring just inside the muzzle of the gun.

Fuze, Time, No. 211. Plate 20.

441. The fuze can be used with:—

- (i) 4-inch to 8 inch H.E. shell.
(ii) 5.25-inch and below Target Smoke shell.

This is a detonating fuze embodying a gaine; it is superseding No. 206 fuze in all H.A. equipments in which the combination of No. 206 fuze and No. 10 gaine is approved.

The design and components are shown in *Plate 20*. The mechanism is housed lower in the body than the No. 206 fuze to improve the strength of the fuze and its ability to resist stresses on firing.

For instructions for fuzing and unfuzing shell see *para.* 487 and 488.

Safety Arrangements.

442. The fuze embodies the following safety arrangements:—

- (i) The striker is kept away from the detonator by a cam-shaped foot which rests on a pillar. Should any fault in the mechanism allow the foot to come off the pillar before the fuze is rotated, further movement of the striker towards the detonator is arrested by the centrifugal safety catch which engages the foot and becomes locked. Subsequent rotation of the fuze will not free this lock and a fuze fired in this condition would be blind.
- (ii) During flight the centrifugal safety catch opens and does not interfere with the striker, which is released after the passage of the "set" time.
- (iii) The centrifugally operated shutter blanks off the passage between the detonator and the magazine. A detent holds the shutter in the "SAFE" position.
- (iv) The bridge piece prevents the hand of the clockwork mechanism from rising until the mechanism of the fuze has run for approximately one second. This prevents premature bursts occurring inside the muzzle of the gun.

Before Loading.

443. The watertight cap is unscrewed and removed. The fuze is set by turning the dome to the required fuze setting; this operation shears the dome shearing pin.

Action—On Firing.

444. There are two series of actions, namely, those caused by set-back (which occur simultaneously) and those caused by the rotation of the projectile.

In the first series :—

- (i) The locking weights set back and force the locking pins into the space between the dome and the body, thus preventing any further relative movement between them.
- (ii) The trigger sets back and frees the hand, thus allowing the mechanism to start. The hand revolves anti-clockwise and the hand spring continues to force it against the underside of the hand race.
- (iii) The detent sets back against its spring and frees the shutter.

In the second series :—

- (i) The centrifugal safety catch swings clear, allowing a free passage for the foot on the striker when it drops off the pillar.
- (ii) The detent topples and locks itself back under the shoulder of the detent hole.
- (iii) As the shutter is no longer held by the detent it slides over against the pressure of the shutter springs into the armed position.

Action—During Flight and on Burst.

445. The hand revolves until it comes into line with the gate in the hand race. The hand spring forces the hand through the gate and the end of the striker lever is released. This allows the striker to turn so that its foot drops off the pillar. The striker spring forces the striker down and its point pierces the detonator. Flash from the detonator ignites the C.E. in the stemmed channel in the shutter and the magazine is detonated.

Fuze, Time, No. 215.

446. This fuze is for use with 4.5-inch to 5.25-inch Star shell.

The safety arrangements and action are similar to those of No. 207, Mark III fuze, with a longer time of running. (Maximum of 80 seconds.)

CH. XII—SECTION 4.—TIME AND PERCUSSION FUZES

447. These are Time fuzes embodying a percussion mechanism which works on the inertia principle.

The fuze will function on impact before the time mechanism is due to function or if the time mechanism fails to function correctly. These fuzes are obsolescent.

The safety arrangements are detailed in the description of the No. 93 fuze.

Fuze, Time, Percussion, No. 93, Mark I. Plate 17.

448. This fuze is for use with 6-inch to 15-inch Shrapnel shell. It is a clamping fuze and its design and components are shown in the illustration.

Safety Arrangements.

449. The fuze embodies the following safety arrangements :—

- Time Portion.*—(i) The time pellet carrying the detonator is prevented from falling on the needle by a stirrup spring and a safety pin.
- (ii) While the fuze is set to *SAFE*, accidental ignition of the detonator will not ignite the magazine as the flash holes are blanked.

Percussion Portion.—The percussion detonator is prevented from moving forward on to the percussion needle by a steel ball interposed between the top of the pellet and the top of the recess in the body of the fuze. It is also retained by the stirrup spring taking under the brass ferrule.

Before Loading.

450. The safety pin is removed. The cap is eased back (right-hand screw), the bottom ring is set to the fuze setting ordered and the cap screwed down again. No attempt should be made to replace the safety pin once it has been removed, and if not required for immediate use, the fuze must be removed from the shell and thrown overboard.

CH. XII—SECTION 5

Action—On Firing.

451. *Time Portion.*—The inertia of the time pellet causes it to set back through the stirrup spring on to the time needle. Flash from the detonator ignites the fuze powder in the top ring and the powder burns as in the No. 198 fuze.

Percussion Portion.—The inertia of the ferrule causes it to set back, straightening out the arms of the stirrup spring and exposing the hole in the body in line with the steel ball. Centrifugal force causes the ball to fly out into this hole. The fuze is now armed, the percussion pellet being held back only by the creep spring.

Action—On Burst or Impact.

452. When the fuze powder has burnt the flash passes down into and ignites the fuze magazine. If the shell strikes an object before the time portion has functioned, the percussion detonator pellet will set forward on to the percussion needle; this will ignite the detonator, and the resulting flash will pass into and ignite the fuze magazine.

453.

CH. XII—SECTION 5.—DRILL FUZES

Drill, Percussion, Direct Action, Fuzes.

454. No. 45P and No. 230 are in service. They are converted service fuzes with all explosives and ignition arrangements removed, or solid plugs shaped to represent service fuzes.

Drill Time Fuzes.

455. These consist of converted service fuzes with all explosives and ignition arrangements removed, or of specially manufactured plugs contoured to represent service fuzes. They can be used for fuze setting drill. Fuzes, drill, time, No. 206, Mark II, No. 207 and No. 211, Mark III, are provided with removable rings which can be replaced when worn.

Marking of Drill Fuzes :—

456. (i) All fuze bodies are black.
 (ii) The caps of 45P drill fuzes are red.
 (iii) The portions of time fuzes on which the graduations are engraved are left bright.
 (iv) The word "DRILL" is stamped on them.

ANY FUZE WHICH IS NOT BLACK, OR WHICH DOES NOT HAVE THE WORD "DRILL" STAMPED UPON IT, SHOULD BE TREATED AS LIVE.

CH. XII—SECTION 6.—GAINES

457. Gaines are used with igniferous fuzes (and occasionally with detonating fuzes) to produce detonation of the shell filling and are fitted in the shell directly below the fuze. They are actuated by pressure from the explosion of the fuze magazine and initiate the detonation wave which is conveyed through the exploder to the shell filling.

Gaines are fitted in all H.E. shell with 2-inch fuze holes, except shell for 3.7-inch howitzer and shell using fuze No. 211. Gaines are also used in some Target Smoke and special Bombardment shell. The letter Z after a Mark indicates that a Lead Azide Detonator is fitted.

Gainé, No. 10. Plate 19.

458. This gainé is for use with :—

- (i) 3-inch to 8-inch, 14-inch, 15-inch (B.N.F.) and 16-inch H.E. shell.
 (ii) 5.25-inch and below Target Smoke shell.

The design and components of the gainé are shown in the illustration.

Safety Arrangements.

459. This gainé embodies the following safety arrangements :—

- (i) The detonator is not in line with the needle before firing. Should the needle be forced back by any cause its point will take in a hole in the shutter. The shutter is held in its safety position by a spring and a detent.
 (ii) Accidental ignition of the detonator will not fire the magazine as the detonator is not in line with the fire channel. Should the detonator fire accidentally, the gases generated will pass down into the vent hole.
 (iii) During flight, the needle is kept clear of the detonator by the needle disc.

Action—On Firing.

460. The detent sets back against its spring and frees the shutter which moves, under the influence of centrifugal force, until the detonator is in the centre line of the gaine between the needle and the fire channel.

Action—On Burst.

461. The gases produced by the ignition of the magazine of the fuze force the needle of the gaine back on to the detonator. The detonator disrupts and starts the chain of detonation which passes through the C.E. in the fire channel into the magazine of the gaine.

Gaine, No. 9.

462. This gaine is similar to No. 10, except that it is manufactured in lead free material, and therefore can be used in shell filled with high explosive containing Picric Acid.

Gaine, No. 11. Plate 19.

463. This gaine is for use with:—

- (i) 12-pdr. 12-cwt. and 3-inch H.E. shell.
- (ii) 4.5-inch, 4.7-inch, 5.25-inch, 6-inch (Mark XXIII guns) and 8-inch Chemical Bursting shell.

The design and components are shown in the illustration.

Safety Arrangement.

464. The centrifugally operated shutter blanks off the channel between the detonator and the fire channel of the magazine.

Action—On Firing.

465. Centrifugal force causes the shutter to swing over against the pressure of its spring. The stemmed channel in the shutter is thus brought into line with the detonator and fire channel of the magazine.

Action—On Burst.

466. The gases produced by the ignition of the fuze magazine cause the detonator of the gaine to disrupt. The chain of detonation passes through the C.E. in the shutter and the fire channel into the magazine of the gaine.

CH. XII—SECTION 7.—DETONATORS FOR FUZES AND GAINES

467. A "true" detonator is one which on initiation will transmit a wave of detonation to the high explosive filling of a fuze or gaine.

The term "detonator" has been used rather loosely and it became customary to refer to caps filled with an igniferous composition as detonators.

Both true detonators and igniferous composition filled detonators are fitted in fuzes used in Naval Service, and to avoid confusion true detonators will be referred to as "Disruptive" detonators and igniferous composition filled detonators as "Igniferous" detonators.

The greatest care is taken to ensure that detonators are correctly made, that they are clean and that no loose fulminate or igniferous composition is on the exterior. In spite of precautions it is possible that over-sensitive detonators may sometimes be passed into the service, and it is therefore of the utmost importance that detonators or fuzes containing detonators should be very carefully handled.

468. Fulminate of mercury and igniferous compositions are liable to deteriorate and to become unserviceable with time; the rate of deterioration of igniferous compositions is very much less than that of pure fulminate.

No age limit is placed on the life of detonators filled with igniferous compositions or on composite detonators filled with igniferous composition and lead azide. A life of ten years is placed on detonators of pure fulminate. The speed of deterioration is increased with the temperature of storage.

DISRUPTIVE DETONATORS

469. Disruptive detonators are fitted in Percussion D.A., and Time No. 211 fuzes and in all gaines.

The container is of copper and the filling consists of (i) a top layer of "A" mixture and a bottom layer of lead azide, or (ii) a charge of pure fulminate of mercury.

Detonators filled in the first manner have the letter "Z" suffixed to their nomenclature.

Disruptive detonators are initiated by a direct blow from a sharp hard needle which causes a molecular disruption and a wave of detonation is propagated to the fuze magazine.

CH. XII—SECTION 7.

470. The several types of disruptive detonator used are :—

<i>4-grain detonator</i> (filled fulminate of mercury) now superseded for current filling by the 5-grain "Z"	No. 18 fuze No. 18P fuze No. 19A fuze No. 45P fuze (Marks II, VII/II, VII****/II XI/II) No. 131 fuze No. 11 gaine (Mark HIZY)
<i>4-grain detonator</i> (filled C.E. and lead azide)	
<i>5-grain detonator</i> (filled fulminate of mercury) now superseded for current filling by the 5-grain "Z"	No. 44 fuze (all marks up to and including Mark X) No. 45P fuze (Marks VIII, VIII**, X) No. 8 gaine (all marks up to and including Mark IV)
<i>5-grain "Z" detonator</i> (filled composition "A" and lead azide)	No. 44 fuze (all marks above Mark X) No. 45P fuze (Marks VII****Z/II, VIII**Z, XZ, XIZ/II) No. 117 fuze No. 118 fuze No. 230 fuze No. 230P fuze No. 240 fuze No. 241 and 248 fuze No. 360 fuze No. 360 C fuze No. 211 fuze, No. 720 fuze No. 8 gaine (all marks above Mark IV) No. 9 and 10 gaine No. 11 gaine (Mark I) No. 720 fuze (magazine detonator) as alternative to the 5-grain "Z"
<i>5-grain detonator</i> (filled A.S.A.)	
<i>6-grain detonator</i> (filled C.E. and lead azide)	No. 254 fuze (Marks II and IV) No. 258 fuze (Mark I)
<i>10-grain detonator</i> (filled fulminate of mercury)	No. 2 gaine (both detonator and gaine are obsolescent)
<i>2.8-grain "Z" detonator</i> (filled composition "A" and lead azide)	Fuze Bomb Hydrostatic No. 1

IGNIFEROUS DETONATORS

471. Igniferous detonators ignite gunpowder by flash and their usual function is to ignite the powder filling of a fuze magazine.

These detonators contain one of two types of filling according to their service :—

- (A) Detonators for Base fuzes, the percussion part of Time and Percussion fuzes and Nos. 243 and 246 fuzes are filled entirely with A mixture. This type of filling is also used in Fuzes Nos. 206 and 207.
- (B) Special detonators for Time and the time part of Time and Percussion fuzes, filled approximately half and half with B mixture and a powder pellet.

472. A and B compositions are mixtures of the following substances :—

	A MIXTURE	B MIXTURE
<i>Fulminate of Mercury</i>	6 parts by weight	11 per cent. by weight.
<i>Chlorate of potash</i>	6 parts by weight.	52.5 per cent. by weight.
<i>Antimony sulphide</i>	4 parts by weight.	36.5 per cent. by weight.

Igniferous Detonators, Filled "A" Mixture.

473. These detonators are made in three sizes—3, 2 and 1.7 grain. They are designed to be struck by a needle on the top and are fitted in the following fuzes :—

<i>3-grain detonator</i>	All medium and large base percussion fuzes.
	No. 206 fuze } Time mechanical fuze.
	No. 207 fuze }
<i>2-grain detonator</i>	Fuze, percussion, base, Hotchkiss.
<i>1.7-grain detonator</i>	No. 81 fuze } (Time and percussion fuzes—percussion arrange-
	No. 93 fuze } ment)
	No. 243 fuze } With larger hole in the detonator.
	No. 246 fuze }
	No. 720 fuze } With larger hole in the detonator for percussion arrangement.

Igniferous Detonators, Filled "B" Mixture and Powder.

474. This type of detonator is used in the time arrangement in Time, Time and Percussion and fuze No. 720, Marks I to III. These detonators are more squarely shaped than the plain igniferous detonators and are designed to be struck by a needle on the bottom.

The detonators fitted to the different types of Time fuze differ slightly in filling and construction, but are all made on the above lines.

As an example, the weights of explosive filling in the detonator for fuze No. 198 are :—

- 1.1 grains detonating composition "B."
- 1.41 grains of gunpowder.

CH. XII—SECTION 8.—MISCELLANEOUS

Failures and Accidents with Fuzes.

475. "Blinds" or "Prematures" may occur with any type of fuze. They may also occur through a fault in the shell or its filling quite apart from the misbehaviour of the fuze.

With percussion mechanisms a blind usually indicates that the main detonator of the fuze has failed to fire. With time mechanisms it may mean that (1) the detonator of the igniting arrangement has failed to function, or (2) the time rings have failed to ignite, or (3) the time ring having ignited, the fuze powder has failed to continue burning or to convey the flash to the magazine. The net result is the same in all cases—the fuze does not function.

Blinds in fuzes may be due to any one of a large number of causes or even to a combination of causes which it is impossible to determine without investigation. One of the non-technical reasons may be the failure to remove the safety pin or/and safety cap.

The term "premature" applied to a fuze indicates that some portion of the fuze has functioned sooner than was intended, with the result that the shell filling is exploded prematurely.

476. By reason of the Safety Arrangements in fuzes a premature action of the fuze detonator will not always result in the premature explosion of the shell. In fuzes, however, where there is nothing to prevent the flash from the detonator reaching the fuze magazine the premature action of the detonator will result in the immediate explosion of the fuze. A premature ignition of a fuze detonator may result in a shell bursting when the gun is fired and before the shell has had time to reach the muzzle. A similar accident may occur owing to a defective shell or filling.

It is important when reporting prematures to take great care to ensure that full particulars of the shell, the fuze and the charge used in the gun are reported to the Admiralty; this will enable the matter to be fully investigated and avoid suspicion being thrown on the fuze or on the shell when the other is really responsible for the accident.

Prematures in fuzes may be due to a large number of causes, and it is impossible without thorough investigation to determine the cause of any one accidental explosion.

Firing through Muzzle Covers.

477. Base fuzed shells are not liable to premature if fired through a muzzle cover, even if the cover is coated with ice. Nose fuzed shells may premature if fired through a muzzle cover, and if they do not they will probably be blind.

478. *For Guns, 2-pdr. to 12-pdr. inclusive.*—When muzzle covers of any nature are in place, whether or not they are likely to be coated with ice, the first round fired should be a practice projectile or a base fuzed shell.

479. *For Guns, 3-inch and above :—*

- (i) When circumstances are such that throughout the whole period during which the guns are likely to remain loaded, formation of ice is not liable to occur, all shells, whether base fuzed or with direct action fuzes (including K device shells) or time fuzes, may be fired through muzzle covers if conditions make it desirable to keep covers in place. The exceptions to the above are fuzes Nos. 44 and 45P. Shell fuzed with these fuzes are not to be fired through covers, and when they are in use and it is necessary to keep covers in place, the first round must be a practice projectile or a base fuzed shell.
- (ii) When ice is liable to form, base fuzed shells and K device shells may still be fired through the covers, but shell fuzed D.A. or those fitted with time fuzes should not be fired. A practice projectile (or a base fuzed shell, according to circumstances) should be the first round fired.

Note.—Cartridge, Q.F. 40 mm. Practice (weighted and plugged shell) must be used for 40 mm. Bofors guns and not Cartridges Q.F. 40 mm. Projectile Practice (fuzed and filled S.R.274).

CH. XII—SECTION 9.

Care of Fuzes.

480. Instructions for the care of fuzes supplied separately in tin cylinders are set out in the N.M. & E.R.s.

Should the watertightness of fuzes supplied in their component shell be compromised in any way (*e.g.*, by removing the pin or by setting of a time ring) that fuze, if not immediately fired, should be regarded as unfit for service, and the complete round returned to a Naval Armament Depot at the earliest opportunity.

Metal Fuze Covers.

481. Metal fuze covers have proved superior to rubber covers.

Metal covers are not to be removed until absolutely necessary, due regard being paid to operational and weather conditions.

In the event of fuze failures the routine report (Form No. S.1148(j)) is to state the period of time between the removal of the fuze cover and firing, together with any remarks as to weather conditions, etc., to which the shell may have been exposed before and during that period, and which may be helpful in determining the cause of the failure.

Kit Plasters.

482. Kit plasters form a method of waterproofing and a means of protection for fuzes of shell in ready-use racks in exposed positions. Instructions for use are contained in N.M. & E.R.

The plasters consist essentially of a conical canvas cap soaked in kit composition and placed over the nose of the fuzed shell. They can be readily removed by the becketts without the use of a key or other instrument. Kit plasters are supplied for No. 44 fuzes.

483. *The method to be used when fitting a plaster is:—*

- (i) Remove any grease from the nose of the fuze.
- (ii) Heat the composition in an ordinary gluepot. It should remain at full heat for about 15 minutes before it is used.
- (iii) Men handling the plasters should rub a little mineral grease over their hands to prevent the composition adhering.
- (iv) Place a paper cover (supplied with the plaster) over the nose of the fuze to prevent the composition adhering to the fuze.
- (v) Dip the plaster into the composition and keep it there for one minute, so that it may be well saturated.
- (vi) Lift the plaster from the composition and allow it to cool until the composition is no longer runny.
- (vii) Two men should each take hold of two loops and pull the plaster quickly over the nose of the shell, seams out. The seams should then be pressed down with a suitable piece of wood.
- (viii) Finally, dip the nose of shell 4.7-inch and below into the hot composition till the composition just covers the junction between the bottom of the plaster and the shell. With shell above 4.7-inch, apply a coat of composition with a brush. Scrape off any composition which runs down on to the body of the shell when it is stood on its base.
- (ix) To facilitate removal of the plaster, a becket of spun yarn should be rove through all four loops of the plaster. A tug on this becket will pull all four loops at once.

CH. XII—SECTION 9.—FUZING AND UNFUZING SHELL

GENERAL.

484. Regulations concerning the safety precautions to be observed while fuzing and unfuzing shell are set out in N.M.E.R.

Shell 6-pdr. and below and all shell for submarines are supplied fuzed.

As a wartime measure H.E. shell 5.25-inch and below fitted with Fuzes No. 206 or No. 207 are supplied fuzed.

In ships other than D.E.M.S., Fast Liners and Auxiliary Vessels, H.E. shell for use with Time Combustion fuzes are supplied plugged, with gages in position (if fitted). Certain H.E. shell for use with Percussion, D.A., Fuzes, are also issued plugged.

For D.E.M.S., Fast Liners and Auxiliary Vessels, shell below 6-inch are supplied fuzed; 6-inch shell are issued plugged and are fuzed on board with assistance from Naval Armament Supply personnel.

All components that screw into the base of a shell (*i.e.*, base fuzes, tracers) have left-hand screw-threads. Nose fuzes have right-hand screw-threads.

INSTRUCTIONS TO FUZE—GENERAL.

485. (i) Ease the " grub " or fixing screw in the nose of the shell right back to ensure that it clears the threads of the plug. The screw recess will be found full of luting.
- (ii) Unscrew the plug from the fuze hole and remove the plug and washer. Washers which are sometimes fitted round the head of a No. 8 gaine should not be removed. If the plug cannot be unscrewed with the service fuze key, the shell is to be landed at the first opportunity at a Naval Armament Depot.
- (iii) Wipe the threads of the fuze hole to ensure that no explosive is left on them.
- (iv) Coat the threads of the fuze with Mark V luting, taking care that no luting is applied to the bottom of the fuze. Place a fillet of Mark VI luting or R.D. 1205A under the washer. No lubricant other than Mark V luting is to be used ; it is to be applied with a new brush. Mark VI luting is tacky and should be applied with a wooden spatula.
- (v) See that the gaine is screwed home. With a No. 8 gaine this is done by feeling with the fingers that the head of the gaine is below the surrounding washer (care being taken that the pressure plate of the gaine is not touched) ; with other gaines it is done by feeling that the gaine itself is not loose. If the gaine is not screwed home the shell is to be returned to a Naval Armament Depot.
- (vi) Fit washers to the fuzes as follows :—
Nos. 44 and 45P—no washers.
Percussion, D.A., Time, Time and Percussion—a copper asbestos washer unless a washer has already been fitted.
- (vii) (a) Insert the fuze and screw home, using no more force than can be applied by hand with the service fuze key. The washer must be kept central so that no part of it protrudes beyond the side.
- (b) Fuzes fitting G.S. fuze holes (*i.e.*, Nos. 44 and 45P fuzes) are screwed in by their caps, which are slotted across or provided with a square recess in the top. The cap turns the fuze by the body pins, on to which the cap fits with a bayonet joint. It is not always possible, because of the taper of the G.S. hole, to screw the fuze far enough in for the underside of the head to bear on the bottom of the recess in the nose bush and a slight protrusion of the fuze is to be accepted ; a fillet of Mark VI luting is applied in the recess in the shell under the head of the fuze. It is essential with fuzes having a screw-down watertight safety cap and tightening plug (*e.g.*, No. 45P fuzes) that the tightening plug should be in the screwed down position when the fuze is in the shell.
- (c) Fuzes fitting 2-inch holes are screwed in by the body. The fitting key takes into a groove or hole in the body. Thus, in Time fuzes with watertight covers the cover must be removed before screwing in the fuze.
- (d) Time and Time-and-Percussion fuzes must be set SAFE before they are inserted.
- (viii) Screw the grub screw firmly home. Fill up its recess with luting, Mark VI.
- (ix) Protect the head of the fuze from damp. This is applicable only to No. 44 and earlier marks of No. 45P, which have no watertight cap and have not already been water-proofed in depot.

The procedure is :—

- (a) Untie the knot in the becket of the safety pin. The becket is rove through the crown of the safety cap. No. 44 fuzes, Marks X and later, do not have a becket.
- (b) Remove the securing pin or pins. In No. 44 fuzes, Mark X and later, this also removes the safety pin.
- (c) Remove the safety cap carefully so as to avoid any strain on the becket of the safety pin.
- (d) Examine the Pettman cement over the head of the fuze to see that it is sound and in good condition ; if it is not in good condition the luting may work down into the fuze and saturate the detonator. Fuzes which are not in good condition should be returned to a Naval Armament Depot.
- (e) Coat the top portion of the fuze with Mark IV luting, placing a thick layer over the head of the fuze. In applying luting to the head of a No. 44 fuze care must be taken to avoid depressing the needle disc as this will fire the detonator.
- (f) Reeve the becket of the safety pin through the crown of the safety cap.
- (g) Replace the safety cap.
- (h) Replace the securing pin or pins and open out the split ends. In fuzes No. 44, Mark X and later, replace the safety pin ; if any difficulty is encountered in so doing the fuze should be removed and returned to a Naval Armament Depot unless it is likely to be fired in the near future.

CH. XII—SECTION 9.

(j) Re-knot the becket of the safety pin.

Note.—In future manufacture the luting may be applied to the head of the fuze at the fuze-filling factory. No further waterproofing on board will be necessary with these fuzes.

(x) With D.A. fuzes stencil the word "FUZED" on the shell with the special vermilion paint.

INSTRUCTIONS TO UNFUZE—GENERAL.

486. Unfuzing shell is carried out by reversing the operations just described :—

- (i) Ease the grub screw right back.
- (ii) Unscrew the fuze with the service fuze key (using no more force than can be applied by hand). If the fuze cannot be removed by this means, the fuzed shell must be returned to a Naval Armament Depot at the first opportunity.
- (iii) Examine the fuze to see that no part of it remains in the shell. If a portion remains in the shell, the shell is to be handled with care, kept in the horizontal position and lowered overboard in deep water. The remainder of the fuze should be handled with care and thrown overboard at once. In no circumstances should any attempt be made to remove a portion of a fuze remaining in a shell on board H.M. Ships.
- (iv) Insert the plug, with leather washer under the flange, and follow a procedure similar to that in (iii), (iv) and (vii) of *para. 485*. The threads of the plug must be wiped clean before applying the luting. Screw up the grub screw and fill its recess with luting Mark VI. Care is to be taken that the correct type of plug is placed in the shell.
- (v) Strike through the word "FUZED" with vermilion paint.
- (vi) Replace the fuze in a tin cylinder and seal it.

TIME MECHANICAL FUZES AND FUZE NO. 230.

487. Shell supplied fuzed with No. 206, 207 or 211 fuzes may also be used with Fuze No. 230 over Gaine No. 9 or 10 and *vice versa*. When a No. 211 fuze is fitted on board in place of any other fuze and gaine, the "G.9" or "G.10" marking on the shell should be erased or barred out and if a No. 211 fuze is being replaced by other fuze and gaine, the "G.9" or "G.10" as applicable, should be added by stencil to denote the presence of a gaine.

To Fuze with Fuze No. 211.

488. Ease the grub screw fully back and remove the plug (with leather washer) by means of Key No. 48, Mark I, or a suitable screw driver, taking care that the components of the exploder system are not spilled from the shell. To ensure that all the components are in place a "gauge," depth of cavity, filled H.E. shell, No. 7 is supplied. The gauge should be applied to the shell cavity, using the longer end of the gauge which is marked "NOT GO." The bottom of the gauge will rest, without pressure, on the exploder in the cavity and the flange should be just clear of the nose of the shell. If the gauge, without undue pressure, touches the nose of the shell on both sides the shell should be re-plugged and returned to a Naval Armament Depot at the first opportunity.

If the gauging is correct screw in the fuze (which has a copper asbestos washer secured to it) using Key No. 89, Mark III (Schedule of keys, page 131). Screw the grub screw firmly home and fill the recess with luting, Mark VI.

To Fuze with Fuze No. 230 over Gaine No. 9 or 10.

489. Ease the grub screw fully back and remove the plug No. 20 (with leather washer) or fuze No. 211, taking care that the components of the exploder system are not spilled from the shell. Gauge the cavity with gauge No. 7 as described above for No. 211. Insert gaine No. 9 or 10 by means of Key No. 69, Mark II. The gaine, when screwed down, need not make metal-to-metal contact with the seating in the shell, but should give firm compression to the exploder system. Undue force is not to be used. Apply gauge No. 7 to the fuze hole using the end marked "GO" after insertion of gaine. The flange should make metal-to-metal contact with the nose of the shell. If gauging is correct, insert Fuze No. 230, using Key No. 121, Mark I (taking care that the copper asbestos washer, which is provided with the fuze, is in place). Screw the grub screw firmly home. Fill the recess with luting, Mark VI.

To Remove Fuze No. 230 and Gaine No. 9 or 10.

490. Ease the grub screw fully back and unscrew Fuze No. 230 (with the C. & A. washer) and unscrew the gaine, using the same implements as those for fuzing described above. No undue force should be used. The shell can then be fuzed with Fuze No. 211 or plugged with Plug No. 20; the precautions and gauging as set out in *para. 488* being observed.

FUZES IN 14-INCH, 15-INCH AND 16-INCH, H.E. SHELL. *Fig. 5.*

491. These shell, when prepared for time fuzes, are marked with the word "TIME" in two places on the nose. If 15-inch H.E. shell have zinc alloy caps in place, the caps should be removed and left off after fuzing. The approved luting is Mark VII or VIII.

To remove Time Combustion Fuzes in 14-inch and 16-inch H.E. Shell and Fuze with Fuze No. 118.

492. (a) Slack back the fixing screw.
 (b) Remove the time fuze with key No. 89 and replace in its tape-banded cylinder.
 (c) Remove the gaine No. 9 or 10 with key No. 69 and place similarly in its cylinder.
 (d) Insert exploder, 3 oz. C.E. pellet, with lifting band.
 (e) Using gauge No. 9 test the depth of cavity, and if correct, insert two tracing cloth discs on top of the exploder. Gauge No. 9 is a "Not Go" gauge, and when used, the bottom of the gauge will rest, without pressure, on the exploder, 3 oz. C.E. pellet, in the cavity and the flange should be just clear of the nose of the shell. Should the cavity be of incorrect depth, the shell must be returned to the nearest Naval Armament Depot.
 (f) Insert fuze No. 118 with copper-asbestos washer under flange with Keys No. 113 or No. 121, using luting where and as described on the Diagram.
 (g) Tighten the fixing screw and cover with luting as called for on the Diagram.
 (h) At this stage the stencilling of the word "Time" in two places should be Carred through but not obliterated, in order that it may be known that this shell can be explodered to take a gaine and time fuze.

To remove Fuze No. 118 in 14-inch and 16-inch H.E. Shell and Fuze with a Time Combustion Fuze.

493. (a) Slack back the fixing screw.
 (b) Remove the fuze No. 118 with Keys No. 113 or No. 121 and replace in its tape-banded cylinder.
 (c) Remove the two tracing cloth discs and lift out the exploder, 3 oz. C.E. pellet, using a hook made of brass wire. In order to ensure that all components are in place and suitable for receiving a slight compression upon the insertion of No. 9 or 10 gaine, a gauge, depth of cavity filled H.E. shell No. 7, is supplied. Apply this gauge to the shell cavity using the longer end of the gauge marked "Not Go." The bottom of the gauge will rest, without pressure, on the exploding unit in the cavity and the flange should be just clear of the nose of the shell. If the gauge, without undue pressure touches the nose of the shell on both sides, the shell should be replugged and returned to an Armament Depot at the first opportunity.
 (d) If the gauging is correct insert gaine No. 9 or 10 with Key No. 69.
 (e) Apply gauge No. 7 to the fuze hole, using the end marked "Go after insertion of gaine." The flange should make metal to metal contact with the nose of the shell. If incorrect, the shell should be returned, plugged with plug fuze hole 2-inch No. 11 to the nearest Naval Armament Depot. On no account should plug fuze hole 2-inch No. 13 be inserted.
 (f) If the depth is correct insert fuze No. 400, placing a copper-asbestos washer under the flange, or fuze No. 401, which has a copper-asbestos washer secured to it, with Key No. 89, using luting where and as described on the Diagram.
 (g) Tighten the fixing screw and cover with luting as called for on the Diagram.
 (h) The word TIME should be re-stencilled on the shell.

To remove a Time Combustion Fuze in 15-inch H.E., B.N.F. Shell and Fuze with Fuze No. 360.

494. (a) Slack back the fixing screw.
 (b) Remove the time fuze with key No. 89 and replace in its tape-banded cylinder.
 (c) Remove the gaine No. 9 or 10 with key No. 69 and place similarly in its cylinder.
 (d) Remove the two tracing cloth discs, lift out the exploder, 26 dram C.E. pellet, together with the three glazeboard discs placed at the underside between the pellet and lifting band, using a hook made of brass wire.
 (e) Insert exploder, 5-oz. T.N.T. pellet, with lifting band, followed by two tracing cloth discs.
 (f) Using gauge No. 9 test the depth of cavity. Gauge No. 9 is a "NOT GO" gauge, and when used the bottom of the gauge will rest, without pressure, on the tracing cloth discs in the cavity and the flange should be just clear of nose of shell. Should the cavity be of incorrect depth, the shell should be returned to the nearest Naval Armament Depot.
 (g) Insert fuze No. 360 with a copper washer under the flange with keys No. 113 or No. 121, using luting sparingly on the threads, and also on the copper-asbestos washer to make an effective seal. At this stage fuze No. 360 should have the safety cap removed and the watertight cover in place.

Note.—In the event of the shell being required for use against targets which the common pointed shell were designed to attack, a special steel nose plug will be supplied to replace the No. 360 fuze.

- (h) Tighten the fixing screw and cover with luting.
 (i) Assemble the zinc alloy cap, using luting sparingly on the thread and also on the flange.
 (j) At this stage the stencilling of the word "TIME" in two places on the head should be barred through but not obliterated, in order that it may be known that this shell can be explodered to take a gaine and time fuze.

CH. XII—SECTION 9.

To remove Fuze No. 360 in 15-inch H.E., B.N.F. Shell and Fuze with Time Combustion Fuze.

495. (a) Remove zinc alloy cap.
 (b) Slack back fixing screw.
 (c) Remove fuze No. 360 with keys, No. 113 or No. 121, and replace in its tape-banded cylinder.
 (d) Remove the two tracing cloth discs and lift out the exploder, 5 oz. T.N.T. pellet, using a hook made of brass wire.
 (e) Insert exploder, 26 dr. C.E. pellet, with three glazeboard discs between the lifting band and bottom of the exploder and follow by the insertion of two tracing cloth discs. To ensure that all components are in place and suitable for receiving a slight compression upon the insertion of No. 9 or 10 gaine, a gauge depth of cavity filled H.E. shell No. 7 is supplied.
 Apply the gauge to the shell cavity, using the longer end of the gauge marked "NOT GO." The bottom of the gauge will rest, without pressure, on the exploding unit in the cavity, and the flange should be just clear of the end of the nose of the shell. If the gauge without undue pressure touches the nose of the shell on both sides, the shell should be re-plugged and returned to an Armament Depot at the first opportunity.
 (f) If the gauging is correct, insert gaine No. 9 or 10 with key No. 69.
 (g) Apply gauge No. 7 to the fuze hole, using the end marked "GO" after insertion of the gaine." The flange should make metal-to-metal contact with the nose of the shell. If incorrect, the shell should be returned plugged with plug fuze hole, 2-inch No. 11, to the nearest Naval Armament Depot. On no account should plug fuze hole, 2-inch, No. 13 be inserted.
 (h) If the depth is correct, insert fuze No. 400, placing a copper-asbestos washer under flange, or fuze No. 401 which has a copper asbestos washer secured to it, using luting sparingly on the threads and also on the copper-asbestos washer to make an effective seal.
Note.—On no account should an attempt be made to replace a zinc alloy cap on a shell that has time fuze in place.
 (j) Tighten the fixing screw and cover with luting.
 (k) The word "TIME" should be re-stencilled on the shell.

H.E. SHELL WITH A UNIVERSAL CAVITY 4-INCH TO 16-INCH.

495A. Shell fitted with a standard size of universal depth of cavity have been recently introduced to permit an exchange of fuzing arrangements to be carried out on board.

A list of shell so fitted with the appropriate fuzes and their exploder units are set out in the Addendum to this Handbook. These shell will have the letter "U" stencilled on opposite sides of the head as a means of identification.

Shell which have tracer fitted are not to be fitted with Fuzes Marks 56 and 60. When Fuzes Marks 56 or 60 are being fitted LUTING must not be used on the threads of fuze, fuze hole, screw, or screw hole; these must

- (1) be wiped clean of luting
 and
 (2) be dry before insertion of the fuze and grub screw.

Luting is to be used only on the underside of the copper-asbestos jointing washer under the fuze and for filling the recess over the grub screw when the screw is home.

Fuzes together with their appropriate exploder units are packed in metal cylinders and are supplied ready for insertion into the shell cavity. A lifting band is fitted to the exploder unit and enables it to be lifted as a whole. It must be used when the exploder unit is withdrawn from or inserted in the shell or cylinder.

To Exchange Fuzing Arrangements.

Ease the grub screw fully back, unscrew and remove the plug or fuze, or fuze and gaine (as applicable) from the shell. Withdraw the exploder unit from the shell. These arrangements should then be placed in the appropriate metal cylinder, which should be marked suitably with a label for identification purposes and closed. When placing a gaine in its cylinder care must be taken to ensure that the plastic washer of the cylinder is positioned below the plastic adapter with the gaine intruding. The gaine must be screwed into the adapter and the shoulder below the thread on the gaine must be flush with the top face of the washer when the washer and the adapter are in contact. This ensures that the gaine will not exert any undue pressure on the exploder unit or permit play between the bottom of the gaine and the exploder unit.

Remove the fuze, or fuze and gaine required, and the exploder unit and the packing from the cylinder. Insert the exploder unit into the empty cavity of the shell, felt end first, followed by two tracing cloth discs. When a gaine is being fitted it must be screwed home on to its seating with Key No. 69, Mark II, to ensure the correct compression of the exploder unit. Check this by applying Gauge No. 7 to the fuze hole, using the end marked "GO" after insertion of gaine. The flange of the gauge should make metal-to-metal contact with the nose of the shell. Screw the fuze home with its appropriate key and screw the grub screw firmly home.

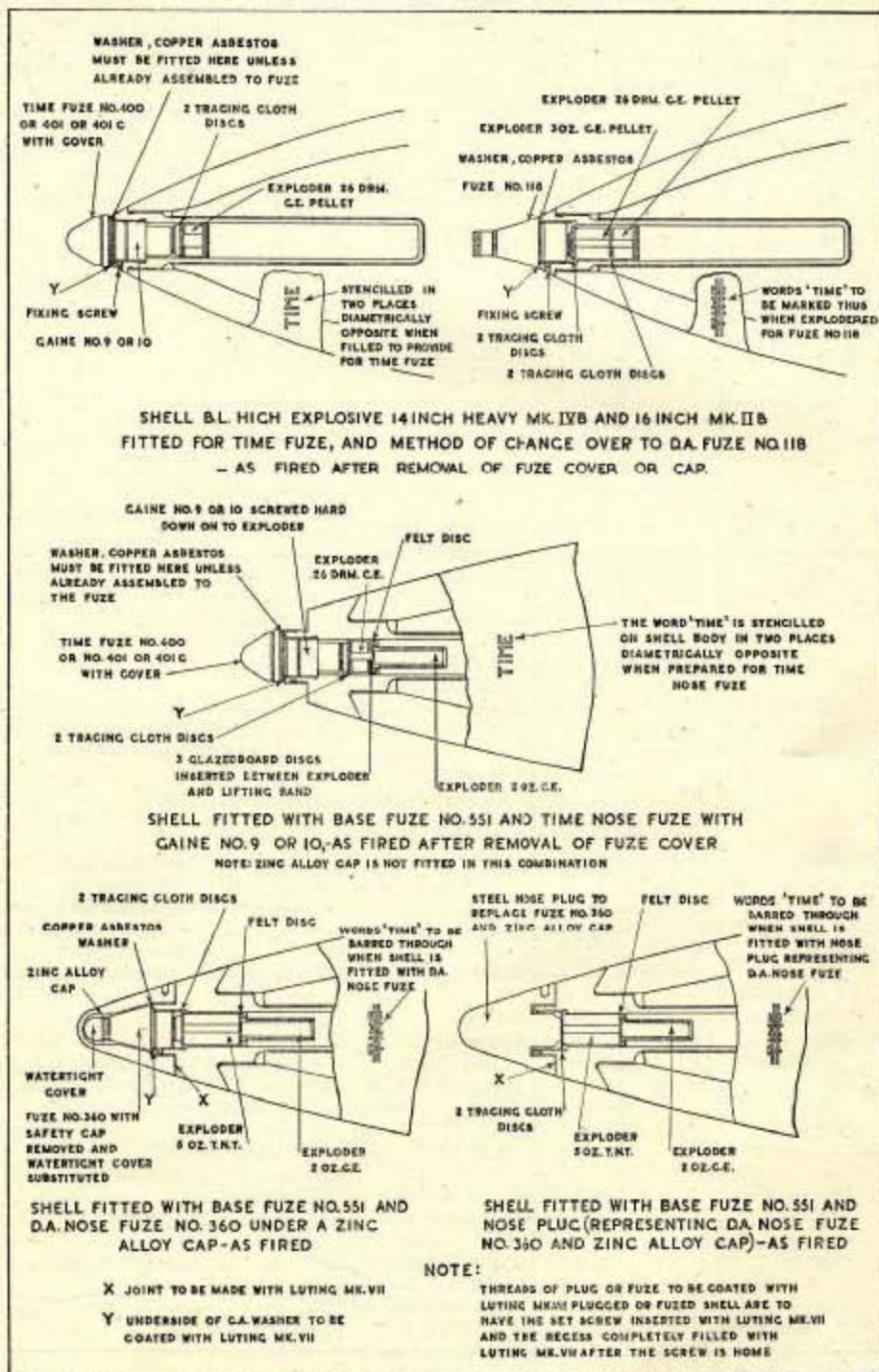

FIG. 5.—FUZES IN 14-IN., 15-IN., AND 16-IN. SHELL.

CH. XII—SECTION 9.

496.

FUZES AND GAINES IN USE IN THE NAVAL SERVICE

TYPE AND SERVICE NO. OF FUZE	PARA.	PLATE NO.	PROJECTILES IN WHICH USED	GUN	REMARKS
Percussion, Direct Action.					
19A	—	—	H.E.	3-pdr. and 6-pdr.	O.F.M.
45P	348	16	H.E.	12-pdr. to 6-inch	For anti-ship use against thin plates
44	353	16	H.E.	3-pdr. to 15-inch	For bombardment
117	—	—	Smoke Shell Smoke Shell (A.Q.)	6-inch 6-inch	} Or Fuze No. 118
118	358	16	Chemical Bursting without a Gain H.E. Shell without Gain	6-inch Mark XII 3.7-inch to 14-inch to 16-inch	
230	359	16	Chemical Bursting without a Gain H.E. Shell with Gain	6-inch, Mark XII 8-inch and below	
	—	—	Target Smoke	4.7-inch	
	—	—	Chemical Bursting with Gain No. 11	4.5-inch to 8-inch, except 6-inch Mark XII	
360C	364	—	H.E., B.N.F. (without Gain)	15-inch	
240	—	—	H.E.	2-pdr. L.V.	O.F.M.
241	365	17	H.E.	2-pdr. L.V. 3-pdr. and 6-pdr.	Supersedes Nos. 131 and 240
			"K" device Projectiles	6-inch and 8-inch	O.F.M.
243	—	—	H.E.	2-pdr. H.V.	—
246	370	17	H.E.	2-pdr. H.V.	Superseding No. 243
248	369	—	"K" device Projectiles	6-inch to 16-inch	Modified No. 241 to allow use with reduced charges as well as full charges
251	374	—	H.E.	40 mm. Bofors (British)	Superseded by No. 255
252	375	—	Incendiary	20 mm. Hispano	British and American manufacture O.F.M.
253	577	—	H.E. and H.E./I.	20 mm. Hispano	British and American manufacture
254	561	—	H.E., H.E./I. and H.E./I.T.	20 mm. Oerlikon	
255	375	17	H.E.	20 mm. Hispano	Supersedes No. 251
258	561	—	H.E./I. and H.E./I.T.	40 mm. Bofors	British manufacture only
259	378	—	H.E.	20 mm. Oerlikon 40 mm. Bofors	—
Percussion, Base, Hotchkiss	383	18	Steel Shell C.P. Shell	3-pdr. and 6-pdr. 2-pdr.	
Percussion, Base, Small					
293	—	—	S.A.P.	2-pdr.	

TYPE AND SERVICE NO. OF FUZE	PARA.	PLATE NO.	PROJECTILES IN WHICH USED	GUN	REMARKS
Percussion, Base, Medium.					
12	—	—	C.P. Shell	} 12-pdr. to 4.7-inch	Lead-free metal. Weakened creep spring
12F	—	—	C.P. Shell		
12F.R.	—	—	C.P. Shell	} 4.7-inch and below	Lead-free metal. For use under base cover plates. Weakened creep spring
12W.F.	—	—	C.P. Shell		
12F Special	—	—	S.A.P.		
500	387	—	S.A.P.	12-pdr. to 5.25-inch	Supersedes No. 12F Special
501	387 (i)	18	S.A.P.	12-pdr. to 5.25-inch	Supersedes No. 500
502	387 (ii)	—	S.A.P.	4.5-inch, 4.7-inch (62 lb.) and 5.25-inch	Weakened creep spring
551	387 (iii)	—	C.P. H.E., B.N.F.	} 15-inch	Weakened creep spring
Percussion, Base, Large.					
15C	—	—	C.P.C. filled powder	6-inch and above	} Obsolescent
15	—	—	C.P.C. filled powder	6-inch and above	
15 without delay	—	—	C.P.C. filled powder	6-inch	
16D	—	—	A.P.C.; C.P.C.; C.P.B.C. filled shellite	6-inch and above	} Supersedes No. 16D
158	—	—	C.P.C. filled T.N.T. A.P.C. filled T.N.T.	15-inch	
158A	—	—	A.P.C. filled shellite	14-inch, 15-inch and 16-inch	} Supersedes Nos. 158 and 158A
159	391 (ii)	—	C.P.C. filled T.N.T.	15-inch	
345	—	—	A.P.C. filled T.N.T. or shellite S.A.P.C. filled T.N.T.	8-inch and above	} Supersedes No. 16D
345A	—	—	S.A.P.C. filled shellite	8-inch	
346	391 (iii)	—	S.A.P.C. filled T.N.T. or shellite	8-inch	Supersedes Nos. 345 and 345A
479	—	—	C.P.B.C.; C.P.C. or S.A.P. filled T.N.T.	6-inch	} Supersedes No. 16D
479A	—	—	C.P.B.C.; C.P.C. or S.A.P. filled shellite	6-inch	
480	391 (v)	18	C.P.B.C.; C.P.C. or S.A.P. filled T.N.T. or shellite	6-inch	Superseding Nos. 479 and 479A
Time, Combustion					
80/44	—	—	H.E. (16 lb.)	3-inch 20 cwt.	Obsolescent
124	—	—	C.N.F.	2-pdr.	O.F.M.

CH. XII—SECTION 9.

TYPE AND SERVICE NO. OF FUZE	PARA.	PLATE NO.	PROJECTILES IN WHICH USED	GUN	REMARKS
Time, Combustion— contd.					
125	411	19	C.N.F.	2-pdr., 3-pdr. and 6-pdr.	Supersedes No. 124 Mean Time set full 16.9 seconds
185	—	—	Target Smoke (12½ lbs.)	3-inch 20 cwt.	Obsolescent
198	417	19	H.E. with gaine	12-pdr. to 8-inch	Mean Time set full 45 seconds
			Star Shell	4-inch and below	
			Smoke Shell B.E.	4-inch to 5.25-inch	
			Chemical B.E.	5.25-inch and 6-inch	
			Target Smoke with gaine	4-inch, 4.7-inch and 5.25-inch	
			H.A. Practice Projectiles	12-pdr. to 8-inch	
			Falling Target Shell	12-pdr.	
400	424	—	H.E. Shell with gaine	12-pdr. to 16-inch	Mean Time set full 9.7 seconds
			Shrapnel Shell	4-inch and below (except 3.7-inch)	
			H.A. Practice Projectiles	12-pdr. to 8-inch	
401	—	—	H.E. Shell with gaine	12-pdr., 3-inch, 4-inch, 14-inch, 15-inch and 16-inch	Mean Time set full— Mark I, 16.7 seconds Mark II, 17.55 seconds
			Shrapnel Shell	4-inch and below (except 3.7-inch)	} Obsolescent. Being used as a temporary measure for projectiles mentioned
			Target Smoke Shell with gaine	5.25-inch and below	
			H.A. Practice Projectiles	12-pdr. 8-inch	
			Falling Target Shell	4-inch Marks V and XVI, 4.5-inch and 5.25-inch	
402	425	19	Shrapnel Shell	4-inch and below (except 3.7-inch)	Intended to function at 500 yards range
Time, Mechanical. 206	435	—	H.E. with gaine	4-inch to 8-inch	Maximum time of running—43 seconds
			Star Shell	4.5-inch to 5.25-inch	
			Target Smoke Shell	5.25-inch and below	
			H.A. Practice Projectiles	4-inch to 8-inch	

TYPE AND SERVICE NO. OF FUZE	PARA.	PLATE NO.	PROJECTILES IN WHICH USED	GUN	REMARKS
Time, Mechanical— <i>contd.</i> 207	440	—	H.E. with gaine Star Shell	4-inch to 8-inch 4-inch Mark XVI, 4.5-inch to 5.25-inch	Maximum time of running—43 seconds
211	441	20	Chemical B.E. Target Smoke Shell H.A. Practice Projectiles	4.5-inch and 4.7-inch 5.25-inch and below 4-inch to 8-inch	
215	446	—	H.E. without a gaine Target Smoke Shell without a gaine Star Shell	4-inch to 8-inch 5.25-inch and below 4.5-inch, 5.25-inch (in Cruisers and above)	
Time and Percussion 80 93	— 448	— 17	Shrapnel Shell Shrapnel Shell	3.7-inch 6-inch to 15-inch	
Gaines No. 2	—	—	Target Smoke (12½ lbs.)	3-inch 20 cwt.	Obsolescent
No. 8	—	—	H.E.	3-inch to 8-inch	Used in conjunction with No. 230 or Time Fuzes
No. 9	462	—	Target Smoke H.E.	4-inch and 4.7-inch 3-inch to 8-inch, 14-inch, 15-inch (B.N.F.) and 16-inch	
No. 10	458	19	Target Smoke Shell H.E.	5.25-inch and below 3-inch to 8-inch, 14-inch, 15-inch (B.N.F.) and 16-inch	Superseding No. 8. Cannot be used with shell fillings containing Picric Acid
No. 11	463	19	Target Smoke Shell H.E. Chemical Bursting Shell	5.25-inch and below 12-pdr. and 3-inch 4.5-inch to 8-inch (except 6-inch Mark XII)	

CHAPTER XIII

SMALL ARMS AMMUNITION

SECTION 1.—GENERAL REMARKS

505. Small Arms Ammunition is used with rifles, machine guns, machine carbines, sub-machine guns, revolvers and pistols.

The term "Small Arms Cartridges" includes the complete round—cartridge case, percussion cap, propellant charge and bullet.

All Small Arms cartridges, with the exception of the Cartridge, Aiming Rifle 1-inch Electric, are fired by percussion, and the resulting flash ignites the propellant charge.

Ammunition of British design for rifles, machine guns and machine carbines of the calibres 0.303-inch, 7.92-mm., 9-mm., 0.5-inch (Vickers and Browning), and 0.55-inch is dealt with in *Sections 1 and 2* of this Chapter. Ammunition of British design for revolvers and pistols of the calibres 0.455-inch and 0.380-inch, is dealt with in *Section 3*, and American Small Arms ammunition in supply, other than Oerlikon, in *Section 4*.

Ammunition with special features is described for —20-mm. guns in *Chapter XIV*; for 1-inch Aiming Rifle and 0.22-inch Miniature Rifle in *Chapter XV*; and for rifles fitted with Grenade Discharger in *Chapter XVIII*.

CARTRIDGE CASE.

506. Cases (except Drill and Dummy) are of solid drawn brass. Their design is on similar lines to that of the Q.F. case for a gun, except that a Cap Chamber and Anvil are recessed in the base instead of a primer. Two fire holes are drilled through the bottom of this recess. The case is tapered from base to shoulder and has a bottle-neck near the mouth to secure the bullet.

507. There are two types of case:—

- (i) *Rimmed*.—A rim or flange is formed round the base to position the cartridge and assist its extraction. All 0.303-inch cartridges are rimmed.
- (ii) *Rimless*.—A groove is cut round near the base to assist extraction. The case is positioned by its shoulder seating on the "lead" or forward tapered end of the chamber. All rifle and machine gun cartridges except 0.303-inch are rimless.

The copper or brass percussion cap is partly filled with Cap Composition. It is pressed into the cap chamber, with the composition hard against the Anvil, and is secured by stabbing or ringing. It must fit tightly all round so that there can be no escape of gas between the cap and the case on firing. Varnish is applied between the cap and the case to make the joint water and gas tight.

A beeswax mixture may be filled into the cannellure of the bullet to render the ammunition watertight. An alternative and more modern method is to varnish the neck of the case internally or the bullet externally before inserting it in the case.

PROPELLANT CHARGE.

508. This is packed in the cartridge case.

The chief propellants are:—

- (i) *Cordite M.D.T.*
- (ii) *Neonite*.—The neonites are nitrocellulose powders, usually in the form of graphited flakes, composed of gelatinised nitrocellulose with diphenylamine as stabiliser and coated with a moderant.

With a cordite charge a glazed board or strawboard disc is inserted between the bullet and the charge. Its function is to control the gases at the moment of discharge, lessen barrel wear and thus increase the accuracy of the flight of the bullet.

THE BULLET.

509. This has a cylindrical body, an ogival head and a flat or boat-tailed base (except Tracer, which have open bases). It is composite and has an envelope, a core and/or a filling. Bullets may be reinforced by the addition of one or two sleeves between the envelope and the core or filling.

Envelopes are of:—

- (i) Cupro-nickel (silver colour);
- (ii) Gilding metal (copper colour);
- (iii) Soft steel, coated with one of these substances externally and/or internally.

Ductile materials are used so that on engaging the rifling there is neither too much strain on the bullet nor undue wear on the rifling.

The features of the core and/or filling vary with the type of cartridge.

Normally, one or two cannelures are cut in the body of the bullet near the base, and the bullet is secured in the cartridge case by indenting and/or coning the case into the cannelure.

510. A bullet differs from a projectile or shell in that having no driving band it is made to engage the rifling of the rifle or gun by:—

- (i) "Set up" (*i.e.*, expansion of the base of the bullet).
- (ii) Being slightly larger in diameter than the bore of the rifle or gun.

The trajectory or line of flight of a bullet is influenced by gravity and air resistance, and the extent of the resistance depends on such factors as angle of elevation, muzzle velocity, rotation, weight, shape, etc.

The weight and muzzle velocity of bullets of the various types of cartridge of the same calibre vary, and when mixed types are fired from a belt or magazine the bullets will not follow the same line of flight. To ensure accurate shooting with mixed types of cartridges, modern cartridges are "matched" so that at a given range all bullets will reach the same point or target. Matching is effected by adjusting the weight or shape of the bullets or the quantity of the propellant charge.

MARKINGS AND MEANS OF IDENTIFICATION. *Plate 21.*

511. Types of cartridges may be identified by:—

- (i) The colour of the varnished ring or annulus. Some types of cartridge have the tips of the bullets coloured in addition, and the colour of the tip thus provides the means of identification and *NOT* the colour of the annulus.
- (ii) Each type of cartridge except Ball has a code letter stamped on the base of the case preceding the mark numeral.
- (iii) The mark numeral is stamped on the base of the case.

512. Code.

SERIAL NO.	CARTRIDGES	CODE LETTER	COLOUR OF ANNULUS
1	Ball	Nil	Purple
2	Practice	P	Purple
3	Armour-Piercing (A.P.)	W	Green
4	Semi-Armour-Piercing (S.A.P.)	F	Green
5	Tracer	G	Red
6	Incendiary	B	Blue
7	Proof	Q	Yellow
8	Blank or Bulleted Blank	L	Nil
9	Drill	D	Nil
10	Dummy	U	Nil
11	Observing	O	Black
12	Explosive	R	Black
13	Grenade Discharger	H	Colourless
14	Smoke Generator Discharger	E	Colourless
15	Self destroying	Y	According to rules set out below

513. Incendiary cartridges and special tracer for use by aircraft have the tips of the bullets coloured as a means of identification:—

Short range day tracer	White
Short range night tracer	Grey
Incendiary	Blue

A colour-varnished annulus of the appropriate code colour is also used.

Where a cartridge possesses more than one characteristic (*e.g.*, S.A.P. tracer) and therefore comes under two or more serial numbers, all the relevant code letters will be used. The sequence of the code letters and the colour of the annulus is governed by the following order of precedence:—

Q, O, R, W, F, B, G, Y, P.

Thus, S.A.P. tracer, serial Nos. 4 and 5, has code letters FG in this order, and the annulus colour is green, since F precedes G.

If the propellant is other than cordite, a letter is stamped on the cartridge case to denote the nature of the propellant:—

T	Black Powder.
Z	Nitro-cellulose or Ballistite.

514. The following particulars are stamped on the base of a cartridge case:—

- (i) The manufacturer's initials or trade mark

CH XIII—SECTION 2.

- (ii) Year of manufacture (usually only the last two figures).
- (iii) The distinguishing letter or letters denoting the type of cartridge.
- (iv) The mark numeral of the cartridge followed, where necessary, by the letter denoting the nature of the propellant.

CH. XIII—SECTION 2.—TYPES OF CARTRIDGE. *Plate 21.*

515. The cartridge case, percussion cap and propellant described in *Section 1* are typical for Small Arms ammunition of British design for rifles, machine guns, machine carbines and sub-machine guns.

The present types of cartridge are :—

Ball, Armour-Piercing (A.P.), Semi-Armour-Piercing (S.A.P.), Tracer, S.A.P. Tracer, Incendiary, Proof, Blank, Drill, Dummy and Observing.

The components for a type of cartridge are similar in its various calibres, differing only in size or amount.

Cartridge, S.A. Ball. *Plate 21.*

516. No Code Letter. Annulus Colour—Purple.

The cartridge is supplied for all calibres except 0.5-inch Browning for use against personnel.

The bullet envelope is of cupro-nickel, gilding metal, or steel coated with cupro-nickel or gilding metal. Its core is lead antimony with an aluminium, plastic or fibre tip, or mild steel with a lead antimony tip. The tip may be adjusted to the correct weight for the required ballistics and balances the bullet to ensure accuracy in flight. The 9-mm. bullet has no tip.

Note :—American 0.5-inch Browning is in supply. Cartridges for Vickers and Browning 0.50-inch machine guns are not interchangeable ; they differ in length and other dimensions.

Cartridge, S.A. Armour-Piercing. *Plate 21.*

517. Code letter W. Annulus Colour—Green.

Cartridges are in supply in the following calibres :—

7.92-mm. 0.303-inch, 0.5-inch (Vickers), and 0.55-inch.

The bullet is specially reinforced to attack armour plate. It has an envelope of cupro-nickel, gilding metal, or steel coated with cupro-nickel or gilding metal, a sleeve of lead antimony and a core of hard steel. The perforating power of the bullet is dependent on the striking energy of the core and the angle at which it strikes the plate. On impact with armour plate the core will perforate and the envelope and sleeve will flatten out and support the point of the core during the first instant of penetration, acting as a lubricant to assist its passage through the plate.

Cartridge, S.A. Semi-Armour-Piercing.

518. Code Letter F. Annulus Colour—Green.

The cartridge is in supply only for the 0.5-inch Vickers machine gun. It is similar to A.P., except that the core of its bullet is of mild steel.

Cartridge, S.A. Tracer. *Plate 21.*

519. Code Letter G. Annulus Colour—Red.

Cartridges are in supply in the following calibres :—

7.92-mm., 0.303-inch, 0.5-inch (Browning) and 0.55-inch.

Tracers are sometimes referred to as " Ball Tracer " to distinguish them from S.A.P. Tracer.

This type of cartridge enables the line of flight of the bullet to be observed to assist in correction of aim.

The bullet consists of an envelope, a core, a filling and a washer. The envelope is of cupro-nickel, gilding metal or steel coated with cupro-nickel or gilding metal. The core consists of a front section of lead antimony and a rear section is a solid drawn copper cylinder. Priming and tracer compositions are filled into the rear section and its base is sealed with a brass washer with a central hole. On firing, the heat from the propellant gases ignites the priming and tracer compositions which burn with a bright light and allows the flight of the bullet to be observed.

Dark ignition tracers with a trace which is not evident until the projectile is some distance from the muzzle of the gun are in supply for certain calibres.

The object of this type of tracer is to minimise blinding at night and to prevent the gunlayer being confused by the trace just outside the muzzle. To some extent they also avoid disclosing the position of the gun.

520. The tracer bullet is of lighter weight than Ball or A.P. and, by reason of the burning away of the tracer composition, its weight decreases during flight. In consequence and as a result of the

effect produced by the burning tracer composition being forced out of the rear of the bullet, the trajectories of tracer bullets differ from those of other bullets. Tracer cartridges are matched-up with other types of cartridge, but they are naturally less destructive than Ball or A.P., and are liable to foul the barrel. This latter disability is overcome by mixing the various types of cartridge in the belts and magazines. The length of trace (*i.e.*, time of burning) is regulated by adjusting the tracer composition.

Cartridge, S.A. Semi-Armour-Piercing Tracer.

521. Code Letter FG. Annulus Colour—Green.

This cartridge is in supply only for the 0.5-inch Vickers machine gun. It is similar to Tracer, except that the front section of the core of the bullet is of mild steel.

Cartridge, S.A. Incendiary. Plate 21.

522. Code Letter B. Annulus Colour—Blue.

Cartridges are in supply in the following calibres:—

7.92-mm., 0.303-inch, 0.5-inch (Vickers and Browning).

The cartridge is used primarily to attack aircraft. The sensitivity and incendiary effect of the bullet is such that it will perforate the skin of an aircraft without ignition and penetrate its self-sealing tank and ignite the petrol.

The bullet consists of an envelope, sleeves, base discs and a filling of Incendiary composition.

The early marks of 0.303-inch were filled with white phosphorus; these are now obsolescent.

Cartridge, S.A. Proof.

523. Code Letter Q. Annulus Colour—Yellow.

Cartridges are in supply in the following calibres:—

7.92-mm., 0.303-inch, 9-mm., 0.5-inch (Vickers) and 0.55-inch.

This is a Ball cartridge with an increased propellant charge which gives a higher pressure. It is used for proving guns.

Cartridge, S.A. Blank.

524. Code Letter L. Annulus Colour—Nil.

The cartridge is special to 0.303-inch calibre. It has no bullet and its main purpose is to make a loud report.

The propellant charge consists of 10 grains of sliced cordite Mark I Size 20, or 15 grains of nitro-cellulose. A strawboard wad is fixed above the charge in the neck of the case which is closed by necking and crimping.

Cases manufactured for other types of cartridge may be used for Blank and markings other than the correct ones may be found; for example, a rejected Ball case may be used and the Ball mark numeral remains.

Cartridge, S.A. Drill. Plate 21.

525. Code Letter D. Annulus Colour—Nil.

Cartridges are in supply in the following calibres:—

7.92-mm., 0.303-inch, 9-mm., 0.5-inch (Vickers), and 0.55-inch.

These cartridges are used for training purposes; they may also be included at the end of belts of cartridges for machine guns to remind the gun's crew to reload. The original type of case is chromium-plate with three vertical grooves which are painted red. There is no propellant charge or percussion cap. The recess forming the cap chamber is painted red and left empty.

Since the commencement of hostilities another type of case has been introduced. This case is an ordinary brass service case with four holes bored in the side and the recess forming the cap chamber is left empty.

Cartridge, S.A. Dummy.

526. Code Letter U. Annulus Colour—Nil.

Cartridges are in supply in the following calibres:—

7.92-mm., 0.303-inch, 9-mm., 0.5-inch (Vickers), and 0.55-inch.

The cartridge is used by inspecting officers and in depots and is not in supply to ships. It is similar to Drill, but has a plain case; the bullet is of gilding metal. The weight and balance of the cartridge are the same as those of Ball.

Cartridge, S.A. Observing.

527. Code Letter O. Annulus Colour—Black.

The cartridge is in supply only for 0.303-inch calibre. The bullet makes a small puff of smoke on impact. The cartridge is used for training purposes to assist in observation of firing.

CH. XIII—SECTION 3.

The cupro-nickel envelope has a hole bored in the nose which is closed with a plug of fusible metal. Phosphorus and powdered aluminium are filled into the envelope which has a lead core. The base is soldered. (The tips of the bullets are varnished black.) This cartridge is obsolescent.

Cartridge, S.A. Rifle Grenade, Ballistite, Mark IZ.

528. Code Letter H. Annulus—colourless. The front half of case is black.

These cartridges are used with (1) Rifles fitted with Dischargers, and (2) Bombs, B.L. H.E. 4-inch, Mortar 10 lb. Mark I. They are blank cartridges with a charge of approximately 30 grains of ballistite. Ballistite is a mixture of soluble nitrocellulose and nitroglycerine, and is rather more powerful than cordite; it is mostly used as a sporting powder. The mouth of the case is closed with a glazed board cup and is not crimped.

Note.—These cartridges must *NOT* be used with (1) a rodded grenade, *e.g.*, Rifle M.L.E., as the ignition of the ballistite is much too rapid and dangerous pressures would be produced; *NOR* with (2) Smoke Float, B.L. 4-inch Mortar, Marks II and III.

Cartridge, S.A. Rifle Grenade, 0.303-inch. Cordite.

529. Code Letter H. Annulus—colourless. The case is black all over.

These cartridges are used with (1) Rifles M.L.E. (line throwing), and (2) Smoke Floats, B.L. 4-inch Mortar, Marks II and III. They are blank cartridges with approximately 43 grains of Cordite M.D. The mouth of the case is closed with a glazed board cup and is not crimped.

Note.—These cartridges must *NOT* be used with (1) Rifles fitted with a discharger as the propellant does not burn rapidly enough to ensure complete ignition; *NOR* with (2) Bomb, B.L. H.E. 4-inch Mortar 10 lb., Mark I.

CH. XIII—SECTION 3.—REVOLVER AND PISTOL AMMUNITION

*Plate 22.***GENERAL.**

530. Each of the many designs of Revolver and Pistol requires special ammunition, but the variations are, in the main, minor ones. The cartridges are composite and have the same main parts as the rifle cartridge. The case may be rimmed, rimless or semi-rimless and have one or more fire holes. The method of ignition is the same as for the rifle cartridge.

531. The types of cartridge are:—

Ball, Proof, Blank and Drill.

The markings and method of identification (except Proof) are the same as the corresponding type of rifle cartridge.

The ammunition described may be considered typical of the present supply.

PISTOL, REVOLVER, No. 1. 0.455-inch.**Cartridge, S.A., Ball.**

532. No Code Letter. Annulus Colour—Purple.

The solid drawn brass case is rimmed and has a cap chamber and anvil recessed in the base. Two fire holes are drilled through the bottom of the recess. The brass or copper cap is filled with cap composition and secured by ringing. The charge is cordite or nitrocellulose.

The bullet has a cupro-nickel envelope and a lead antimony core. The cannellure is filled with beeswax mixture and the bullet is secured by rolling the mouth of the case; it may be further secured by indenting the case into the cannellure.

Cartridge, S.A., Proof.

533. Code Letter Q. Annulus Colour—Yellow. The case is a reddish copper.

The case and cap are the same as for Ball. The charge of cordite or nitrocellulose is loaded to give a pressure of 7 tons.

The bullet is of lead antimony and has three cannellures. It is secured by coning the mouth of the case and rolling the case into the top cannellure.

Cartridge, S.A., Blank.

534. Code Letter L. Annulus Colour—Nil.

The case and cap are the same as for Ball.

The charge consists of approximately 8 grains of gunpowder. Two felt wads are placed above the charge and the mouth of the case is crimped to retain the wads and the charge.

Cartridge, S.A., Drill.

535. Code Letter D. Annulus Colour—Nil.

The white metal or brass case is rimmed and has three vertical grooves painted red. The cap chamber recess is filled with a red fibre pad secured by three stabs.

The bullet is of lead antimony and has three cannellures. It is secured by coning the mouth of the case and rolling the case into the top cannellure.

PISTOL, REVOLVER, No. 2. 0.380-inch.**Cartridge, S.A., Ball.**

536. No Code Letter. Annulus Colour—Purple.

The case is rimmed with the base of the rim bevelled off. The bullet has a cupro-nickel or gilding metal envelope and a lead antimony core. It has two cannelures, the lower being filled with beeswax mixture. The bullet is secured by coning the mouth of the case into the upper cannelure and rolling the case into the lower one.

Cartridges, S.A., Proof and Drill are similar to corresponding types in 0.455-inch calibre.

Cartridge, S.A., Blank has a charge of approximately 5.5-grains of gunpowder which is covered by a felt wad.

PISTOL, 0.455-inch.**Cartridge, S.A., Ball.**

537. No Code Letter. Annulus Colour—Purple.

Ammunition of this calibre is similar to that for the Pistol Revolver No. 1 with the following variations:—

The case is semi-rimless (*i.e.*, it has a groove cut round its base above the rim) and has three fire holes.

The bullet has a copper, nickel plated envelope with a lead antimony core. It has one cannelure and is secured by coning the mouth of the case into the cannelure.

538. **Cartridges, S.A., Proof, Blank and Drill**, differ from Pistol Revolver No. 1 ammunition in that the cases are semi-rimless and (*except Drill*) have three fire holes.

CH. XIII—SECTION 4.—AMERICAN SMALL ARMS AMMUNITION

539. Small Arms Ammunition of American design and manufacture is in supply for what may be considered essentially American calibres of Small Arms, namely, Rifle and Machine Gun 0.30-inch; Thomson Sub-Machine gun, and Smith and Wesson revolver 0.45-inch; and Browning Machine gun 0.5-inch. Ammunition is also in supply for the 9-mm. carbine.

Cartridges are similar to British ammunition except:—

- (i) Cases are of the rimless type. The anvil is a separate unit and is fitted in the percussion cap (termed "primer") before the latter is inserted into the case. Rifle and Machine gun cartridges have one fire hole.
- (ii) The propellant charge is nitrocellulose powder.
- (iii) The bullet envelope (termed "jacket") is of gilding metal and is copper coloured. The base of the bullet may be boat-tailed or flat (*except Tracer which is open*). The bullet is secured in the case by crimping the mouth of the case into the cannelure or where there is no cannelure (*e.g.*, 0.45-inch) by coning.
- (iv) Markings and Means of Identification:—The means of identification is by varnish colour marking the tips of the jackets. The American code of colours is the same as the British code, with the exception of A.P., which may be either black or green. The colour-varnished annulus indicates that waterproof varnish has been applied. The code letter system is not used.

540. The base of the cartridge may be stamped with the initials of the manufacturer, year of manufacture and calibre, but there is no uniform standard. British manufactured ammunition for American calibres has the tips of the jackets coloured and base markings in addition.

Small Arms cartridges of American calibres will not load into British weapons of approximately the same calibre. For example, the base of the 0.30-inch cartridge (rimless) is smaller than that of a 0.303-inch cartridge (rimmed) but the diameter of its case is larger and is too big for a 0.303-inch rifle, gun or links belt. Similarly, 0.5-inch Vickers and Browning cartridges are not interchangeable as they differ in length and in other dimensions as stated above.

541.

TABLE OF AMERICAN CARTRIDGES

CARTRIDGES	CALIBRES	COLOUR OF TIP
Ball	0.30-inch; 9-mm.; 0.45-inch and 0.5-inch	Nil
A.P.	0.30-inch and 0.5-inch	Black or green
Tracer	0.30-inch and 0.5-inch	Red
Tracer with dark ignition	0.5-inch	Orange
Tracer (short range day)	0.30-inch	White
Incendiary	0.30-inch and 0.5-inch	Blue
Dimmy (Drill)	0.30-inch, 0.45-inch and 0.5-inch	Nil
A.P./Incendiary	0.5-inch	Silver

542-549.

CHAPTER XIV

S.A.A.(cont.)— 1-INCH AIMING RIFLE AND MINIATURE RIFLE CARTRIDGES

1-INCH AIMING RIFLE CARTRIDGES. Plate 22.

550. The 1-inch Aiming Rifle Cartridge comes within the definition of Small Arms Ammunition, but it differs from type by having a primer, electric or percussion, instead of the usual percussion cap. It is supplied in bulk, 96 rounds in a box, A.S.A., G.S., H.4.

Cartridge, Aiming Rifle, 1-inch Electric, Mark II.

551. The cartridge comprises a cartridge case, primer, charge and bullet.

The solid drawn brass case is rimmed but is without the usual pronounced bottle-neck to receive and secure the bullet. It is lacquered internally with the exception of the threads of the primer hole and that portion which supports the bullet. The base of the case is marked with the manufacturer's initials or trade mark, the letter N, and the mark numeral of the cartridge.

The brass primer comprises a body and magazine in a single unit. It is screwed into the primer hole and the joint is made tight with a fibre washer. A brass contact pin, insulated from the body by ebonite bushes, is fitted at the base. One end of the bridge wire is soldered to the point of the contact pin and the other to the body. The recess is filled with guncotton dust so as to surround the wire bridge. The charge in its magazine is gunpowder G.20 and the magazine is closed by a glaze-board cup shellacked in position.

On firing, electric current is passed from the contact pin. The bridge wire gets hot and the guncotton dust and the magazines are in turn ignited. The resulting flash ignites the cordite charge.

The charge consists of about 160 grains of cordite, Mark I, size 3.

The lead-antimony alloy bullet weighs approximately 10.5zs. Its two cannelures are filled with beeswax mixture. The rear end of the bullet is reduced in diameter and a copper cup is pressed on firmly and turned in on the bullet.

Cartridge, Aiming Rifle, 1-inch Percussion, Mark III.

552. The cartridge is similar to Electric, Mark II, but is fitted with a percussion primer.

The percussion primer has an anvil and magazine formed internally. The magazine is filled with a gunpowder pellet.

On firing, flash from the cap ignites the magazine and the resulting flash ignites the propellant charge. Gun pressure is prevented from blowing back by the soft copper cap sealing in the body.

MINIATURE RIFLE CARTRIDGES.**0.22-inch Ammunition.**

553. The nomenclature of ammunition of this calibre is "Cartridge, Rim Fire, 0.22-inch, Mark I," and the present Service type of cartridge is known as "Non-Rusting."

The term "Rim-Fire" denotes a cartridge without a percussion cap. The fold of the rim of the case is hollow and is charged with cap composition.

Cartridges are supplied in cardboard boxes of 100; 100 boxes are packed in a quarter M.L. case.

The cartridge comprises the case, charge and bullet.

The case is of copper zinc alloy, solid drawn.

The charge is usually black powder. Cordite, neonite or other nitrocellulose powders may, however, be used according to the particular manufacturer's practice.

The bullet is made of soft lead. It is rounded at the head and has three shallow cannelures, usually lubricated with beeswax mixture. It is secured in the case by coning, necking or crimping.

554-559.

CHAPTER XV

S.A.A. (*cont.*)—20 mm. CARTRIDGES

SECTION 1—GENERAL

560. 20 mm. ammunition is in supply for :—

- (i) Oerlikon and Polsten guns.
- (ii) The Hispano gun.

Oerlikon and Hispano ammunition are not interchangeable. The base of the Oerlikon case is of less diameter than its body, whereas the dimensions of the base and body of the Hispano case are almost identical.

The cartridges for each gun have similar components and comprise—case, percussion cap, propellant charge and a shell or projectile.

The cases are rimless and their brass percussion caps are secured by ringing.

The steel shell are fitted with a copper driving band and, except Semi-Armour-Piercing which are closed with steel nose plugs, a percussion D.A. fuze is screwed in. A cannellure is cut below the driving band and the shell or projectile is secured in the case by indenting.

Practice projectiles are not fitted with a fuze.

SECTION 2—OERLIKON

BRITISH OERLIKON. *Plate 23.*

561. The designs and components of typical ammunition are shown in the illustration.

The fuze fitted is No. 254 or No. 258. Each is a Percussion, Direct Action fuze having no moving parts; the crushing of the fuze on impact actuates the detonator. At action ranges the fuze will perforate the skin of an aircraft without functioning, but it will operate on impact with wing spars, petrol tanks or other heavy structures. At very short ranges the fuze will function on impact with the skin of an aircraft. The No. 258 is the more sensitive fuze and is in supply for H.E./I and H.E./I/T for Naval Service.

The propellant charge is nitro-cellulose, flake or chopped tube.

The shell filling is C.E. or T.N.T. C.E. is obsolete for future manufacture.

The outside of the shell below the driving band is varnished to render the joint between shell and case watertight.

All future Oerlikon tracer of British manufacture will have Dark Ignition. (*See para. 519.*)

Markings and Means of Identification.

562. The types of ammunition are identified by the colour marking on the shell or projectile. The fuze can be identified :—No. 254 is painted the same colour as the shell. No. 258 is not painted except for a blue spot on the nose.

The Lot Number of the shell or projectile, the contractor's initials and, if applicable, the letters D.I. (indicating dark ignition tracer) are stamped on the side of the shell or projectile. Projectiles for Drill (except Drill, Marks I and II) have no stamped markings.

The base of the cartridge case is stamped as follows :—

- (i) Initials or trade mark of the manufacturer of the case.
- (ii) Oe. (*i.e.*, Oerlikon).
- (iii) The letter "Z" (denoting neonite filling).
- (iv) Year of manufacture of case, *e.g.*, '44.

Note.—Oerlikon ammunition of "new" British manufacture will be stamped with details of the lot number and type of ammunition on the cartridge case just in front of the base groove. It will be shown thus :—

S. 167/H.E./I.T.

These details should be quoted in all reports dealing with defective ammunition.

Types of Ammunition. *Plate 23.*

562 (a) The present types of ammunition and the colour markings are :—

Practice	Lead Grey.
Practice Tracer	Light Green.
H.E. Incendiary	Signal Red.
H.E. Incendiary Tracer... ..	Bright Green.

CH. XV—SECTION 2.

S.A.P./H.E./I.	Red with white tip.
H.E.	Buff.
H.E. Tracer	Light Blue.
Proof	Lead Grey with red band round the body.
Drill, Mark I	Black with DRILL in White Letters.
Drill, Mark II	Wood, unpainted.

Projectile, Practice. Colour—Lead Grey.

563. The steel projectile is hollowed to make the weight correct and the nose is pointed to give the required ballistics; the base is closed with a steel disc.

Projectile, Practice Tracer. Colour—Light Green.

564. The projectile is similar to Practice, but for the purpose of ballistic matching the nose is less pointed. The body is partly filled with tracer composition. On firing, heat from the propellant gases ignites the tracer composition which burns for approximately 3½ seconds.

✓ **Shell, H.E., Incendiary. (H.E./I.)** Colour—Signal Red.

565. The filling comprises an increment of Incendiary composition with T.N.T. superimposed and pressed in; a waxed lasting cloth disc separates the T.N.T. filling from the incendiary composition.

On impact, the fuze detonates the T.N.T. filling and the detonation ignites the incendiary composition.

The inclusion of incendiary composition results in an extremely high temperature on detonation, and this is very effective for igniting petrol.

✓ **Shell, H.E., Incendiary, Tracer. (H.E./I./T.)** Colour—Bright Green.

566. The shell is open at both ends and is divided into two compartments. The forward compartment is filled with an increment of Incendiary composition with T.N.T. superimposed and pressed in; a waxed lasting cloth separates the T.N.T. from the incendiary composition. The rear compartment is filled with tracer composition. A thin brass closing disc fits over the tracer composition and is retained in position by a steel washer which is secured into the base of the shell.

On firing, heat from the propellant gases melts the centre of the closing disc and ignites the tracer composition which burns for approximately 3½ seconds. On impact, the fuze detonates the T.N.T. filling and the detonation ignites the incendiary composition.

Shell, Semi-Armour-Piercing H.E./I. (S.A.P./H.E./I.) Colour—Red with White tip.

567. This shell is similar to the H.E./I but a detonator is superimposed on the filling and the head of the shell is closed with a steel nose plug. The shell is detonated on impact with armour plate or heavy metal structure and the incendiary composition is ignited.

Shell, H.E. (H.E.) Colour—Buff.

568. The shell is similar to the H.E./I except for the filling, which is entirely high explosive. This type of ammunition is now obsolescent.

Shell, H.E. Tracer (H.E./T.) Colour—Light Blue.

569. The shell is similar to the H.E./I/T except for the filling, which is entirely high explosive. This type of ammunition is now obsolescent.

Cartridge, Drill, Mark I. Colour—Black with DRILL in White.

570. This cartridge and CARTRIDGE, DRILL, MARK II (described below) are supplied for magazine loading practice and must not be loaded into the gun. The projectile is of cast iron.

The base of the case is stamped:—

- (i) Oe.
- (ii) Letter "D" (denoting "Drill"), and I N (denoting Mark I—Naval).
- (iii) Date of filling barred out.

The cap is removed and a red annulus is painted.

Cartridge, Drill, Mark II. No colour marking.

571. The hardwood cartridge is stamped:—

- (i) Oe.
- (ii) Letter "D" and II N.
- (iii) Contractor's initials or recognised trade mark
- (iv) Year of manufacture, e.g., '44

Clearing Charge.

572. The clearing charge comprises a shortened service cartridge case with a full charge. The propellant is retained by a glazed board cup.

A one-round magazine is supplied to facilitate the use of clearing charges.
The magazine is suitable for any mark of gun.

AMERICAN OERLIKON. Plate 23.

573. H.E., H.E./I and H.E./T ammunition of American design and manufacture are in supply. The case and shell are similar to those of British design.

The fuze, No. 26, is a Percussion, D.A. fuze which is an adaptation of the British No. 254 and functions in a similar manner. The propellant charge is graphite tubular neonite. The high explosive filling is either C.E. or Pentolite. Pentolite is now obsolete for future manufacture.

574. The types of ammunition and the filling are distinguished by the colour marking on the shell.

The base of the case is stamped :—

- (i) Contractor's initials or trade mark.
- (ii) Year of manufacture.
- (iii) 20 mm.—Mark II.

575. The following particulars are marked on the side of the case in indelible blue ink :—

- (i) Initials of filler.
- (ii) Lot Number in $\frac{1}{4}$ -inch letters.

576. The present types of ammunition in supply, their filling and colour markings are :—

H.E.	C.E.	White.
H.E.	Pentolite	Yellow.
H.E.T.	C.E.	Light Grey.
H.E.T.	Pentolite	Dark Blue.
H.E.I.	C.E.	Red.
H.E.I.	Pentolite	Pink.

SECTION 3—HISPANO

577. A typical round is shown, for comparison with Oerlikon, in the illustration. (Plate 23.)

The fuze fitted is No. 253. A modified Oerlikon fuze, No. 254 Mark IV, is approved as an alternative.

The propellant charge is nitro-cellulose powder. The high explosive filling is C.E.

Markings and means of Identification.

578. The types of ammunition are identified by the colour markings on the shell or projectiles.

The base of the case is stamped :—

- (i) Manufacturer's initials or trade mark.
- (ii) Year of manufacture.
- (iii) 20 mm.

The colour of the annulus is purple for all types of ammunition except Dummy, which is uncoloured.

The markings stamped on the side of the shell are :—

- (i) Lot Number and last two figures of the year of filling.
- (ii) Filling contractor's initials or trade mark.
- (iii) Mark of complete round and type of propellant.

Types of Ammunition.

579. The present types of ammunition in supply and the colour markings on the shell or projectiles are :—

Ball	Black or blued.
Tracer	Black with T in Red, or red band.
A.P./T. (Day)	Black body, white tip and white band.

CH. XV—SECTION 3.

A.P./T. (Night)	Black body, white tip and green band.
H.E.I.—Top half of body	Buff.
Lower half of body	Red.
Nose of fuze	Green or Red.
A.P.	Black with white tip.
S.A.P. Incendiary	Red with white tip.
Dummy	Black or blued.

Note.—No red band is painted on shell to denote that they are filled.

H.E. and Incendiary are obsolescent.

The above ammunition is similar to the corresponding British types of Oerlikon ammunition described earlier in this Chapter, except the following :—

Cartridge, S.A., Ball. Colour—Black or blued.

580. The projectile is hollow and a metal closing disc in the base prevents the entry of gases into the projectile.

Cartridge, S.A., Armour-Piercing (A.P.). Colour—Black with White tip.

581. This ammunition is for use against armoured fighting vehicles and armour protection in aircraft.

The projectile, which has no filling, is of armour-piercing steel and its pointed tip is fitted with a moulded plastic cap. The length of the cartridge is the same as Ball, and the ammunition can be used in all types of magazine and in belts. Later marks are without a cap and have either an inert filling or a spigoted base plug.

Cartridge, S.A., Armour-Piercing Tracer (A.P./T.). Colour—Black body, white tip and white or green band above the driving band.

581A. The projectile is of armour-piercing steel and is uncapped. There are alternative fillings for Day and Night tracers.

Cartridge, S.A., Semi-Armour-Piercing Incendiary (S.A.P./I). Colour—Red with White tip.

582. This ammunition has been developed for the ignition of aircraft petrol tanks protected by armour plate.

The shell is an H.E. shell body filled with incendiary composition, or alternatively, filled with incendiary composition and having a detonator superimposed. The head is closed with a steel nose plug.

On impact with armour plate or heavy metal structure the shell breaks up and the incendiary composition is ignited. The perforating power is less than that of A.P.

Cartridge, S.A., Dummy. Colour—Black or blued.

583. The cartridge comprises a standard case with three holes drilled in the side about three inches from the base, a wooden distance piece, and a "ball" projectile secured by sweating and rolling.

584-589.

CHAPTER XVI
ROCKET-PROJECTED DEVICES

SECTION I—PROJECTILES

ROCKETS "U" (UNROTATING).

590. These projectiles consist of a cordite rocket or Tail, Propelling, with a shell screwed into the head. They are launched from the rails of a projector instead of being fired from the conventional gun, and are not rotated. Unlike the ammunition of a gun, the charge forms an integral part of the projectile and travels with it in flight until consumed.

591. The original nomenclature was Rocket, Unrotating, Projectile (U.P.), but with the extension of the use of rocket projection, this was changed to Rocket "U" (U denoting Unrotating).

Some of the advantages and disadvantages of rocket projection of shell are :—

Advantages.

- (i) The capacity of the shell of a Rocket "U" is greater than that of a shell of similar calibre fired from a rifled gun.
- (ii) Lower acceleration obviates the necessity for strength against pressure and set-back.
- (iii) Projectors are light and simple.
- (iv) Absence of "deck thrust" on launching.
- (v) Absence of gun wear.
- (vi) Ease and rapidity of manufacture as a complete unit, i.e., projector and projectile or other device.

Disadvantages.

- (i) Less accuracy.
- (ii) Lower average and striking velocity.
- (iii) Slower loading.

Lack of accuracy is partly compensated by using multiple projectors which fire salvos varying up to 20 rounds, and thus it need not be a disadvantage as a shot gun effect is obtained.

Rockets, "U," 2-inch. Plate 24.

592. The 2-inch rocket "U" is an anti-aircraft device.

Only one type of shell is fitted to these rockets, namely, the H.E. shell.

The main components of a round are Tail, Propelling, Tail Fins, Shell and Fuze. These parts are supplied separately for assembly on board and are assembled in the following order :—

- (i) Tail Fins to Tail, Propelling.
- (ii) Shell to Tail, Propelling.
- (iii) Fuze to Shell.

Dismantling is done in the reverse order.

593. *The Tail, Propelling*, is a welded steel tube with a shell ring secured into the head by studs. Below the shell ring the Head Obturator, a cupped disc of thin shell steel, seals the head end of the Tail, Propelling, against leakage of gases. The venturi (nozzle) is welded into the other end of the Tail, Propelling. The bag of silica gel in the venturi is for desiccating purposes. The bottom obturator prevents any leakage of gas past the venturi. The charge of cordite S.U. is castellated at the head; it rests in the tube and is supported at the tail by a grid. A magnesium composition igniter incorporating an electric puffer is fitted in the castellation of the charge.

Electric leads from the igniter pass through the annulus of the cordite to four brass contacts near the tail orifice. The contacts (two positive and two negative) are wired so that proper contact is made with the knife-edges of the mounting, irrespective of the angle at which the round is loaded.

The tail orifice is sealed by a tinned plate closing disc secured in position by R.D. Cement No. 1. The Tail, Propelling, will not self-propel. If there should be accidental ignition of the cordite with a round in an unassembled state, the Head Obturator (which is without the support of the base of a shell) will blow out and the products of combustion will escape from both ends of the tube.

594. *Tail Fins* (4), of steel plate, are inserted into slots in the tube; they are driven back by means of a wooden hammer and latched in position.

595. *The Shell* is of the High Explosive type filled with 9-ozs. of T.N.T. It is screw-threaded near the base to screw into the shell ring of the Tail, Propelling. On firing, the shell gives support to the Head Obturator.

CH. XVI—SECTION 2.

596. *The Fuze, No. 720*, is a wind vane arming, direct action type which arms at a distance of approximately 75 feet from the projector. The self-destruction device operates at a short range of 4,500 feet ($4\frac{1}{2}$ seconds); no shutter is incorporated. An internal and an external detent prevent the wind vane rotating until the round is fired. The external detent is visible and houses into a slot cut into the skirt of the wind vane cap. On firing, acceleration causes both detents to set back.

The wind vanes of the fuze are then free to rotate; approximately five complete turns of the wind vane in an anti-clockwise direction (looked at from the nose) will put the fuze into a direct action functioning condition at the same time releasing the time striker, and the fuze will detonate $4\frac{1}{2}$ seconds later. Additional safety is provided by a safety split pin which is passed through the skirt of the wind vane cap and fuze body. The safety pin prevents rotation of the wind vane cap in either direction and must be removed before loading. The pin is secured in position by means of wire which takes round the body of the fuze and is sealed with a lead seal.

The fuze is not watertight and must be protected from the weather by applications of Grease No. 0, in accordance with the instructions.

Action.

597. The rocket is launched by electric current initiating the electric puffer. The magnesium composition igniter and the cordite charge are ignited. The pressure of gas set up by the burning cordite disperses through the venturi and provides the impetus to the rocket. The cordite burns for approximately .8 second, during which period the rocket is accelerating.

SECTION 2—ILLUMINANTS

2-inch Rocket Flare. Plate 24.

598. The Rocket Flare is launched from a special Projector which is attached to a gunshield, at an elevation of 30° . It is set to burst at 5,000 yards at an approximate height of 2,000 feet; the flare burns for 70 seconds.

The handbook, *B.R.924 Handbook for the 2-inch Rocket Flare*, should be consulted for general instructions, maintenance and detail.

599. The round is supplied for assembly on board and comprises the following main parts—Tail, Propelling, Flare Head and Fins (4).

The order of assembly is:—

- (i) Fins to Tail, Propelling.
- (ii) Flare Head to Tail, Propelling.

600. *The Tail, Propelling*, is similar to the Tail, Propelling, of a 2-inch Rocket "U," except that the Head Obturator is not perforated. The fins are identical to those of the Rocket "U."

601. *The Flare Head Container* is a tinned plate cylinder with two cannelures near the base. The canister, containing the illuminating flare candle with a parachute assembly attached, is inserted in the Container. The Ballistic Cap fits on the forward end of the Container, to which it is secured with adhesive tape. The Base Socket is secured into the other end of the Container by indenting the cannelures; it contains the Thermal Ejector which screws into the shell ring of the Tail, Propelling. The Thermal Ejector consists of a steel base plate with a septum of accurately machined thickness in the centre.

The lower end of a piece of Bickford's Fuze (primary delay) cut to burn approximately 22 seconds makes intimate contact with $2\frac{1}{2}$ grains of L.D.N.R. (lead-dinitro-resorcinate) which is stemmed into the septum recess. The upper end of the Bickford's Fuze projects into the magazine which contains approximately 40 grains of G.12 gunpowder (primary ejection charge). A short piece of Bickford's Fuze (secondary delay) cut to burn for 3 seconds projects from the base end of the canister; the lower end is in close proximity to the primary ejection charge, and the upper end projects into a magazine containing 40 grains of G.12 gunpowder (secondary ejection charge).

Action.

602. On launching the rocket, heat from the cordite propellant is transmitted through the Head Obturator and thin septum of the Thermal Ejector and ignites the L.D.N.R., which, in turn, ignites the lower end of the Bickford's Fuze (primary delay). After 9, 18 or 22 seconds (depending on the mark used) the primary ejection charge is ignited, and the canister is ejected from the container in a forward direction.

The Bickford's Fuze (secondary delay) is initiated by the flash from the primary ejection charge. Three seconds later the secondary ejection charge is ignited and its action ignites the candle and ejects the parachute, cable and candle in a forward direction from the canister. The parachute opens when ejected from the canister and the lighted candle is suspended in mid-air. The purpose of the secondary delay is to allow the velocity of the canister to fall to a speed at which it is safe to eject the flare and the parachute assembly without break-up.

Rocket, Illuminating, 9-lbs. (Snowflake).

603. This store is an illuminant and is used in locating enemy submarines.

The cylindrical *2-inch Powder-filled steel rocket* is similar to Apparatus A.D. Type D; in addition, it is fitted with tail fins (4). The *Parachute Head* contains a parachute with a star and igniting arrangements. The rocket is launched from a Projector Type A or B of Apparatus A.D. Type D, using the appropriate 60 grain cartridge.

Action.

604. When the rocket reaches the vertex of its flight, about 1,500 feet or more, the burster is ignited by the burning rocket composition. Its action ignites the star and expels the parachute and lighted star from the rocket head. The parachute opens out and the burning star is suspended from it; the star burns for about 60 seconds.

SECTION 3—APPARATUS, AIR DEFENCE (A.A.D.)

Apparatus A.D., Type D. Plate 25.

(Parachute and Cable—P.A.C.)

605. This device suspends a cable from a parachute above the firing ship. The cable is rendered lethal on the impact of an attacking aircraft, and aircraft must either keep at a height which precludes accurate bombing or change course.

The Handbook should be consulted for general instructions, maintenance and detail.

The Mark III/N consists of the following main component parts—Rocket with Parachute Head, Main Container, Main Cable and Lower Parachute Assembly. The assembled ammunition is termed "Apparatus A.D. Type D"; it is fired from a "Projector A.A.D. Type D." (Abbreviation P.A.C.).

606. *The Rocket* is a powder-filled 2-inch steel rocket with a tin parachute head attached. A 38-inch diameter parachute and a small gunpowder burster are packed in the parachute head. The painted canvas cover attached to the parachute head fits over the outside of the muzzle of the projector and prevents access of water into the barrel. Two stirrups and a bridle are attached to the rocket; the bridle has about five feet of cable which is covered with asbestos at the rocket end and fitted with a spliced eye for shackling to the Main Cable. Before securing the rocket tail to the Main Container the lid of the Container is removed and the top loop of the K.B. Cable is secured by its swivel to the rocket's wire tail; a short portion of the wire tail is coiled down into the Main Container. The lid is jammed on so as to nip the rocket tail, and it is retained in place until it is dislodged by the pull of the rocket.

607. *The Main Container* is a cylindrical iron box which has two concentric compartments. The outer compartment contains the Main Cable and the inner contains the Lower Parachute Assembly. The lid is detachable. The Main Container is lashed to the deck.

608. *The Main Cable* consists of 400 feet of K.B. 1D wire with a loop at each end and a swivel on each loop. One swivel is attached to the wire tail of the rocket bridle and the other to the Lower Parachute Assembly.

609. *The Lower Parachute Assembly* comprises a 38-inch diameter parachute and a small trail parachute. The larger parachute is packed in canvas and bundled and the small trail parachute is attached.

Action.

610. The 60-grain gunpowder cartridge ejects the rocket from the Projector and also ignites the rocket composition. When the rocket reaches a height of approximately 550 feet, the burning rocket composition ignites and explodes the gunpowder charge in the parachute head and the upper parachute is ejected. At this stage the lower parachute assembly will be approximately 150 feet above the sea, the lower parachute will still be bundled, but the trail parachute will be open. The lower parachute remains in its bundle until the impact of an aircraft with the cable. On impact the trail parachute pulls the ripcord and releases the lower parachute which opens and renders the cable "lethal."

Apparatus, A.D. Type J. Plate 25.

611. The objects and means of operation of this device are similar to those of the A.A.D. Type D. Type J Mark I ejects a 600 ft. 2½ ton cable.

The Handbook B.R.293/44, *Handbook for the Apparatus Type J*, should be consulted for general instructions, maintenance and detail.

The Apparatus is supplied in three main component parts, (i) the Tail, Propelling, (ii) the Head Canister and Thermal Fuze, and (iii) the Main Container.

The round is assembled on issue to ships. The fully assembled round (including the Tail, Propelling) is "Apparatus A.D. Type J." The Apparatus is launched from a "Projector A.A.D. Type J."

612. *The Tail, Propelling*, is similar to the Tail, Propelling, of a 2-inch Rocket "U," except that:—

- (i) The head obturator is not perforated.
- (ii) There are no fins or fin slots.
- (iii) A short stirrup is welded to the exterior of the base of the tube.
- (iv) The venturi is closed with a tinned plate closing disc. The flexible rubber pigtail containing the firing leads is passed through the closing disc; contact studs are omitted.

613. *The Head Canister and Thermal Fuze*.—The Head Canister is of tinned plate and contains a 62-inch parachute; it is made integral with the cast iron ejector cup by soldering. The lower circumference of the Head Canister rests inside the ejector cup on a piston or diaphragm. The base of the ejector cup is screwed into the shell ring of the Tail, Propelling. Provision is made in its base for the Thermal Fuze which is a separate unit.

CH. XVI—SECTION 3.

614. The Thermal Fuze consists of a steel base plate in the centre of which is a thin septum of accurately machined thickness. The lower end of a piece of Bickford's Fuze (cut to burn approximately $4\frac{1}{2}$ seconds) makes intimate contact with the L.D.N.R. (lead-dinitro-recorcinat) stemmed into the septum recess. The upper end of the Bickford's Fuze projects into the magazine which contains approximately 100 grains of G.12 gunpowder. On assembling the Head Canister to the Tail, Propelling, the base of the Thermal Fuze is in close contact with the Head Obturator. On firing, heat is transmitted through the Head Obturator and septum and ignites the L.D.N.R., which in turn ignites the lower end of the Bickford's Fuze. After $4\frac{1}{2}$ seconds the Bickford's Fuze ignites the G.12 gunpowder in the magazine and sufficient pressure is produced to shear the soldered connection between the Head Canister and the Ejector Cup. By means of the force exerted by the Ejector Cup Piston the Head Canister is forced up freeing the 62-inch parachute, which is connected by its shrouds to the Ejector Cup.

615. *The Main Container* for the Mark I Apparatus is a sealed cylindrical iron box with two concentric compartments; it has a heavy non-watertight cover for transit purposes. The Main Container is clamped to the Projector. A 600-foot length of $2\frac{1}{2}$ -ton multi-strand cable is coiled in the outer compartment. One end of the cable is secured to the swivel in the sealed lid of the Container, being secured to the stirrup of the rocket by a pin. The other end of the cable is secured by a swivel to the bundled lower parachute which is contained in a tinned-plate canister in the inner compartment. The lower parachute with its shrouds is packed in a canvas bundle. The bundle is closed by rings through which is passed a cord attached to the Trail Parachute. The Trail Parachute is 20-inches in diameter. It is contained in the tinned-plate canister and opens after leaving the Main Container.

Action.

616. The Parachute Head is blown off and the upper parachute ejected. At this stage the lower parachute and the trail parachute have been lifted approximately 200-feet above the sea. The components suspended from the 62-inch top parachute are in the following order:—Ejector Cup—Spent Rocket Tail and Stirrup—600-feet of Cable—Lower Parachute in Bundle—Trail Parachute.

The lower parachute remains bundled until the impact of an aircraft with the cable. On impact the trail parachute pulls the slipcord and releases the lower parachute. The lower parachute opens immediately and renders the cable "lethal." The upper and lower parachutes are the same size and both exert an equal pull on the aircraft.

Mark IA Apparatus.

617. The Head Canister, Thermal Fuze and Tail, Propelling, are similar to those of Mark I. The Main Container is not sealed by a tinned-plate closing disc. It is fitted with a heavy non-watertight cover for transit purposes which need not be unshipped before firing. The inner canister is watertight, and its lid, secured by soldering, is ripped off on unspooling the cable. Drain holes are fitted in the bottom of the Main Container.

Mark II Apparatus.

618. This differs from Marks I and IA in that the central guide tube is conical and the length of cable is approximately 825-feet. This type of the central guide tube enables the rocket to reach a height of 1,100-feet (against 800-feet) and the Thermal Fuze delay is increased to approximately $6\frac{1}{4}$ seconds.

Apparatus A.D., Type L. Mark I.

619. The object of this device is to lay a curtain of aerial mines suspended from parachutes in the path of low flying or dive-bombing aircraft.

The Handbook, *B.R.843, The 2-inch Rocket, F.A.M., Mark V Mounting*, should be consulted for general instructions, maintenance and detail.

Ammunition is assembled on issue to ships and comprises the Tail, Propelling and the Canister Assembly. The fully assembled round is termed "Apparatus A.D., Type L." The Apparatus is launched from a 2-inch Rocket F.A.M., Mark V, Mounting.

620. *The Tail, Propelling*, is a modification of the Tail, Propelling, of the 2-inch Rocket "U." The contact studs are omitted. The two trunnions are welded on to the tube to accommodate the stirrup. The plug screwed into the shell ring closes the head of the tube; if the plug is removed the rocket is non-self-propulsive in the event of accidental ignition. A 12-inch steel stirrup is attached to the trunnions on the rocket tail. One end of an 18-inch steel connecting rod is secured to the stirrup and the other to a link on the Top Conical Canister. Electric leads pass from the igniter to a flexible cab tyre cable which in turn passes through a mechanically-jointed weak link to a moulded rubber socket on the mounting.

621. *The Canister Assembly* comprises the Top Conical Canister and the Lower Canister. The canisters are joined by the overlap of the sleeve of the Top Canister. The joint is made watertight by a rubber ring and a mixture of luting.

622. The Top Conical Canister is of light gauge steel or tinned plate and contains:—

- (i) The 45-inch diameter parachute to carry down the spent rocket tube.
- (ii) 6-feet Main Support Parachute.
- (iii) 8-inch Bomb Steady Parachute and Weak Link.

- (iv) Upper Explosive Link in bomb housing,
- (v) Three retaining cords which are controlled by the explosive link and hold these parts in position in the canister.
- (vi) The Bomb. The bomb has a light case and a filling of approximately 8-oz. of poured T.N.T. The detonator is held in a shutter kept out of line with the striker by a clock spring. Under sufficient wind pressure the wind vane moves the shutter and brings the detonator in line with the striker. On impact with an aircraft the firing pin is forced in by the universal striker ring and the detonator, being in line with the striker, is fired by percussion. The bomb can be armed and unarmed by large variations in air speed and no self-destruction device is fitted.

623. The Lower Canister is also of light gauge steel or tinned plate, and is mounted on a base plate. It contains:—

- (i) A central tube to assist unspooling the wire.
- (ii) 1,000 feet of 19 s.w.g. piano wire coiled in a metal sheath. One end of the wire is secured by a swivel to the head of the bomb; the other end passes through the split in the central tube and is secured to the spring wire shock absorber.
- (iii) The drag parachute assembly with a 32-inch parachute in a bag is secured to the shock absorber. The four retaining cords which are controlled by a lower explosive link prevent the parachute opening on the initial snatch at pick up.
- (iv) The electric leads for igniting the delay fuzes leave the base of the canister in a short flexible cab-tyre cable and plug into the lower socket of the mounting. The electric circuit for the three fuzes initiating respectively the rocket, the upper explosive link and the lower explosive link is arranged in "Series" so that failure of one fuze will usually prevent the other two being initiated.

Action.

624. On launching, the rocket and the delay fuzes in the upper and lower explosive links of the Canister Assembly are initiated simultaneously. The rocket takes up the top conical canister and the wire in the lower canister is unspooled. When the wire is fully unspooled the drag parachute assembly is picked up, the snatch tension being kept within safe limits by the long shock absorber. The top conical canister reaches approximately 2,000 feet before the upper and lower explosive links are operated. On the operation of the upper explosive link the bomb and parachutes are pulled out. The 45-inch rocket support parachute is connected to the 6-foot Main Support Parachute by a weak thread which breaks when the rocket parachute is fully pulled out. The operation of the lower explosive link removes the constraint from the drag parachute bag and leaves the parachute free to pull out on the impact of an aircraft with the wire. The bomb will not arm until an aircraft strikes the wire.

On impact, the drag parachute opens and the weak link securing the 6-foot Main Support Parachute will part. The bomb is then pulled down on to the wing of the aircraft by the drag parachute. The bomb is armed by rotation of the wind vane due to its velocity through the air on the way. It is steadied in flight by the 8-inch Bomb Steady Parachute which acts as a drogue.

Mark II Apparatus. Plate 26.

625. The Mark II Apparatus is identical to Mark I Apparatus, except that

- (i) The piano wire coil is 1,500 feet in length.
- (ii) No shock absorber is fitted.
- (iii) One side of the slot in the central tube is flared slightly to assist unspooling.
- (iv) The lower canister is marked with a vertical black line to indicate the position of the slot in the central tube. The canister should be loaded into the projector with this black line *away* from the projector rails, *i.e.*, clearly visible to the loading numbers when facing the front of the projector.

626. The method of functioning is identical with the Mark I. The height attained at separation is little less than that of the Mark I (about 100-feet), but the area covered, 1,900-feet to 400-feet, is 50 per cent. greater. Under adverse conditions the effective operational time, *i.e.*, before the drag parachute hits the water, is reduced to a minimum of 20 seconds from the operation of the top explosive link.

627-629.

CHAPTER XVII

GRENADES

HAND GRENADES.

Grenade No. 36M. Plate 27.

630. Grenade No. 36M (known as the Mill's bomb) is an anti-personnel bomb with a danger zone on detonation of approximately 400 yards. The grenade has a cast iron body which is filled with high explosive.

The body is oval and its exterior is grooved to provide a grip to the hand and also to assist fragmentation. The centre piece is screwed into the base and retained by the Base Plug.

The high explosive filling, Baratol 20/80, is filled into the body through the Filling Hole in the shoulder. The Filling Hole is closed by a screw-threaded plug. The bulk of the main filling is separated from the detonator of the Igniting Set by an air gap interposed by the Striker Chamber, and this disadvantage results in uneven fragmentation.

631. The Centre Piece is of aluminium or tinned brass and comprises two adjacent chambers. The smaller chamber receives the detonator and is empty until the grenade is primed. The larger or Striker Chamber is positioned in the centre of the body and contains the Striker and Striker Spring; the head of the Striker protrudes through the circular hole at the top; the opening in the base receives the cartridge end of the Igniting Set.

The steel Striker is flanged at the base to seat the spring. Its firing face, shaped for rim-firing, is notched to allow the escape of gas through the flange. The striker shaft passes through the body; it is notched at the top to receive the Striker Lever. The Striker Spring is compressed between the top of the chamber and the flange of the Striker.

The Striker Lever is a curved steel lever pivoted on a fulcrum formed on the body of the grenade. It fits closely to the body and is retained in position by a split pin passing over it and through the fulcrum bracket. The short end of the lever fits into a notch on the Striker and holds it up against the action of the compressed spring.

The screw-threaded Base Plug seals the base of the grenade.

The Igniting Set comprises a Detonator, Safety Fuze, 0.22-inch Rim-Fire, Cap and a zinc alloy Cap Chamber. The Cap sits in the Cap Chamber with one end of the Fuze attached. The Fuze is formed into a U-shape to suit the Centre Piece into which the Set fits, and its other end is crimped into the Detonator.

632. There are two types of Igniting Set; these vary only in the time of burning of the fuze. The Set in present supply has a 7-seconds fuze which is coloured yellow. The other Set has a 4-seconds fuze; it is coloured white and has a rubber band round it which should not be removed as it is a means of identification at night.

Note.—Before priming (inserting the detonator) all signs of waterproofing and/or grease are to be removed from around the striker outside the body and under the striker lever. The striker should then be tested for freedom in accordance with B.R. 787.

In future 36M grenades will be issued to ships with the striker waterproofed by lightly applying grease. This should be removed before priming, but the mechanism need not be stripped if the striker is free.

Action.

633. In preparation for action, the Base Plug is unscrewed and the Igniting Set carefully inserted; the Base Plug is then replaced and screwed fully home. In preparation for immediate use, the Safety Pin is withdrawn and the Striker Lever held down by hand. After the grenade is thrown the expansion of the Striker Spring forces the Striker Lever away from the body; the lever pivots on the fulcrum and is thrown clear. The action of the Spring causes the Striker to impinge on and fire the Cap. The resulting flash ignites the Fuze which burns for 7 seconds or 4 seconds (as applicable) before igniting the detonator, which then detonates the main filling. *Care is to be taken that primed grenades are unprimed before return to store or package.*

634. *Marking.*—The body is varnished. A ring of red crosses is painted on the shoulder to denote that the grenade is filled. A green band is painted at the lower end to denote the type of filling.

635. *Packing.*—Grenades are packed 12 in a wooden box marked "Hand Grenades, 7 seconds" (or "4 seconds," if applicable). A base plug key and tin containing 12 igniter sets is packed in each box.

Grenade No. 69, Mark I. Plate 27.

636. This grenade is a light percussion Hand Grenade with a danger zone of approximately 30 yards.

The bakelite body is in two parts, which are screwed together. A band is milled round the exterior to provide a grip to the hand. The head of the body is recessed and screw-threaded to receive the Mechanism Holder which contains the Striker Mechanism. A Safety Cap with milled exterior

fits over the Mechanism Holder and is screwed to it; a strip of adhesive tape is stuck obliquely across the joint of the Body and Safety Cap to prevent the latter unscrewing prematurely.

The Filling Plug and the Base Plug with a small rubber plug are fitted in the lower part of the body. The Base Plug closes the base of the Detonator Sleeve which is a bakelised paper tube positioned in the centre of the Body. The Sleeve contains a No. 46 Detonator and is immediately below the Percussion Cap of the Striker Mechanism.

A high explosive main filling of Amatol 80/20, Lyddite, or Baratol 20/80, is filled into the Body through the Filling Hole.

637. The Striker Mechanism comprises the Striker, Striker Spring, Percussion Cap, Cap Pellet, Lead Ball, Closing Cap and Safety Bolt with Safety Tape attached; the other end of the Safety Tape carries a lead weight. The Safety Bolt passes through holes in the Striker and Mechanism Holder and holds the Striker in position. The Safety Tape is wound round the Mechanism Holder in a prepared groove and is finally housed beneath the Safety Cap to keep the Safety Bolt in position. When the Safety Cap is in position the Striker cannot move forward against the Percussion Cap.

Action.

638. In preparation for action the Base Plug is unscrewed and the Detonator Sleeve examined for obstruction, rough edges, cracks, etc. The Detonator is carefully inserted, open end first, the Base Plug is replaced and screwed fully home. In preparation for immediate use the strip of adhesive tape is pulled from the Safety Cap and the Cap is removed; after removal, the Safety Tape must be held in position by the forefinger and thumb until the grenade is thrown. After the grenade is thrown the Lead Weight attached to the Safety Tape causes the Tape to unwind and pull out the Safety Bolt. The Striker is then free to function the Percussion Cap under the action of the lead ball which has an "all-ways" action on impact. On impact, the Striker impinges on and fires the Cap and the flash ignites the detonator, which detonates the main filling.

639. *Marking.*—A ring of red crosses is painted on the upper body to denote that the grenade is filled. The lower body is painted to denote the type of filling, as follows:—

Amatol 80/20	¼-inch green band.
Lyddite	¼-inch green band with "Lyd." stencilled on the band in ¼-inch white letters.
Baratol 20/80	¼-inch green band with "Bar. 20/80" stencilled on the band in ¼-inch black letters.

640. *Packing.*—Each package contains 34 unprimed grenades and 2 cylinders of 17 detonators No. 46.

RIFLE GRENADE.

641. Rifle Grenades are fired from rifles fitted with Dischargers. The Grenade in supply in Naval Service is the No. 36M fitted with a Gas-Check Plate.

The Gas-Check Plate is a circular steel plate (2½ inches in diameter) with a small screw in its centre to screw into the bottom of the Base Plug. The Plate is a sliding fit in the Discharger and rests on an annular shoulder formed in the metal of the cup.

Discharger No. 1, Mark I, is used with the No. 1 rifle. The barrel of the Discharger is cylindrical (with an inside diameter of 2½ inches) and is threaded internally to receive the Locking Base. Near the lower end a slot forming a gas port is closed by a sliding shutter which can be clamped in position by a Clamping Nut. The locking base is threaded on the outside to fit the barrel and has a central hole threaded to receive the adjusting screw, the top of which is slotted to take the point of the bayonet. Below are two claw levers which engage in the slotted sides of the nose-cap of the rifle.

642. *Cartridge S.A., 0.303-inch. Ballistite, H Mark IZ* is used to eject the grenade. (*Para. 528.*)

Action.

643. The grenade is primed and placed in the Discharger; the Split Pin is withdrawn and the grenade is pushed fully home and the rifle fired. On the grenade being ejected from the Discharger the Safety Lever is released and the action of the grenade is the same as when hand-thrown.

644. *Marking.*—The grenades are marked similarly to the Hand Grenade No. 36M.

645. *Packing.*—Box G.5 Mark III or G.36.

- 12 grenades.
- 12 Igniting Sets in a tinned plate cylinder.
- 14 Cartridges ballistite in a tin-plate box.
- 12 gas-check plates.
- 1 Key.

646-649.

CHAPTER XVIII

HOLMAN PROJECTORS. B.L. 4-INCH MORTAR

PROJECTILE, ILLUMINATING.**Projectile, Illuminating, No. 1.**

650. The store is used as an illuminant. This particular design is fired only from Holman Projectors, Marks IIA or IIS. No. 1 Air or No. 1 Steam is stencilled on the body. The Projectile has a cylindrical body of tin plate which contains a cotton parachute, flare unit and an ignition and ejection charge of gunpowder. The flare unit is attached to the Parachute and is positioned with the ignition charge at the forward end next to the Striker mechanism; the Parachute is below this assembly and nearer the tail. The cast-iron conical nose containing the Striker mechanism is fixed securely to the front of the body; the tail, with four fins, is lightly attached to the rear end.

651. The Striker mechanism comprises the striker, striker cover, .410 cartridge and a length of Safety Fuze; the operating unit consists of a striker, a shear wire and a Safety Pin. The Safety Pin is withdrawn before loading.

Action.

652. On firing, the striker sets back, breaks the shear wire and impinges on the cartridge cap. The flash ignites the Safety Fuze and after a period of delay the gunpowder ejection charge is ignited. The resulting explosion ignites the flare, blows off the tail, and ejects the parachute and flare. The flare burns at a high temperature. The parachute and flare are ejected approximately 7 seconds after firing, and the flame burns for a minimum of 30 seconds. At 45° elevation this represents a height of 325/420 feet at a range of 330/360 yards.

Projectile, Illuminating, No. 2. Plate 28.

653. These are fired only from the cartridge-operated Projector, at present the Holman Projector, Mark III. The Projectile is similar to the "No. 1," except that a gas-check is attached by a tulip spring to the tail. "No. 2 Cordite" is stencilled on the body.

In operation, the gas-check separates from the Projectile when the Projectile leaves the muzzle of the Projector. The parachute and flare are ejected approximately 11 seconds after firing, and the flare burns for a minimum of 30 seconds. At 35° elevation this represents a height of 400/525 feet at a range of 770/1030 yards.

Holman Cartridge.

654. The Cartridge for the Projector, Mark III, has a brass bound case. The mouth of the case is closed by a celluloid cup. A protecting cap is fitted over the cup and must be removed before loading. The charge of 16 grammes of Cordite W.M.T. is initiated by an igniter containing 20 grains of gunpowder T.S.2; a celluloid cup separates the igniter from the charge. The igniter is initiated by a percussion cap filled with cap composition.

Cartridges are supplied in tin-plate boxes of 20.

BOMB, 10-lb. UNDERWATER No. 1, MARK I, WITH GAS CHECK. Plate 28.

655. This high explosive bomb is for use against the two-man submarine. It is fired from Holman Projectors, Mark III or may be thrown by hand.

The design and components of the bomb are shown in the illustration.

The bomb consists of a lightly built, welded cylinder fitted with a tail; a nose adapter is threaded for the fuze, which functions under hydrostatic pressure after being projected into water. It has a fixed setting which operates at a depth of 20 feet. The filling is approximately 4½ lbs. of T.N.T.

Action.

656. Remove the safety pin and adhesive tape covering the holes in the cap of the fuze. When the fuze enters the water hydrostatic pressure acts, through the holes in the cap, on the rubber diaphragm and also on the rubber shutter bellows. The fuze is armed by the shutter being forced over against the shutter spring, bringing the detonator in line with the striker. On reaching the proper depth the hydrostatic pressure operates the rubber diaphragm and forces the striker head and the striker down until the levers are in a horizontal position, thus compressing the striker springs. Immediately on passing the dead centre the striker springs re-assert themselves, driving the striker into the detonator and firing the fuze, and the main filling is detonated.

SMOKE FLOAT, B.L., 4-INCH MORTAR. MARKS II OR III. Plate 29.

657. The design and components are shown in the illustration. The main component parts are—balsa wood cylindrical float, metal container, celluloid container and metal protecting cup.

The cylindrical float has a central steel smoke emission tube which is attached to the lid of the metal container and secured by the split lip of the tube being turned over on to a steel washer. The

float is bound with fabric tape. Later marks may be of other material, but this will not affect the operation of the store.

The metal container holds the smoke composition. It has a perforated central steel tube wrapped in primed muslin with a layer of priming composition between the muslin and the smoke composition.

The celluloid container, with the propellant charge of Ballistite, is cemented to the container.

The metal cup is fitted to protect the charge and must be removed before the round is loaded.

A Cartridge S.A. Rifle Grenade 0.303-inch cordite H is used as the primary charge to fire the mortar (*para. 529*). The ballistite charge of the Smoke Float is the secondary charge.

The range at full elevation of 30° is approximately 550 yards. Should the minimum range, about 50 yards, be required, remove the ballistite charge, elevate the mortar to extreme elevation and fire with the primary cartridge only.

Over land the range can be increased by approximately 200 yards if the Smoke Float is fired without its balsa wood float. To remove the hard grey paper disc from the top of the float, prise up the serrations of the central tube with a flat chisel and a pair of pliers. Take off the steel washer and pull the balsa wood cylinder from the central tube. In this condition the float is loaded as usual, *i.e.*, with smoke box to the rear.

Action.

658. The flash from the primary cartridge ignites the ballistite charge of the smoke float and the float is ejected from the mortar. At the same time flash passes up the igniter tube of the smoke container and ignites the priming and smoke compositions.

BOMB B.L., H.E., 4-INCH MORTAR, 10-lb. MARK I. Plate 29.

659. The main component parts of the bomb are—Fuze No. 152 or a plug, Body with nose and tail adapters, and Tail.

Fuze No. 152.—This is a Percussion D.A. fuze whose design and components are shown in the illustration.

Safety arrangements :—

- (i) A safety cap is fitted which must be removed before firing.
- (ii) The detent holds the ball in such a position as to keep the striker down. The striker point engages in the side of the shutter, thus keeping the detonator, which is held in the shutter, out of line with the flash channel in the magazine.

660. On firing, the detent sets back against the detent spring allowing the ball also to set back into a pocket. This allows the striker, under the action of the striker spring, to move forward and the striker point disengages from the shutter. The shutter moves over, under the action of its spring, and the detonator comes into line with the striker and the flash channel of the magazine. The fuze is then fully armed. On impact the cap is crushed in driving the striker into the detonator and the resulting flash detonates the magazine.

661. *Body.*—The steel body is filled with approximately 2 lbs. of T.N.T. A cavity is moulded in the head of the filling into which is fitted a paper tube. The latter contains the C.E. exploder and receives the lower part of the body of the fuze. The head is closed with the nose adapter, into which the fuze or a plug is screwed. The bottom is closed with a tail adapter which is screw threaded in two gauges, one to secure it into the bomb and the other to receive the tail.

662. *Tail.*—The Tail comprises a perforated steel tube with four fins, each of which has two lightening holes. The tail holds the propellant cartridges and also keeps the bomb steady in flight. The tube contains a cartridge in a celluloid container, a closing plug having an open flash hole and a hardwood plug to fill up the surplus space. The fins are arranged so that one pair of opposite fins contains spring retaining clips; these grip the barrel and position the bomb on loading. Two augmenting cartridges, each in a celluloid container, are fitted opposite to one another in the angles formed by pairs of adjacent fins, and are held in position by a length of spring wire which has a hook at each end. The wire is threaded through the rear lightening hole of each fin and hooked to form a ring.

The fabric cover fitted over the tail protects the cartridge from the weather, and is secured with tape at its mouth.

Action.

663. The cartridge used to fire the mortar is a Rifle Grenade 0.303-inch Ballistite H Mark IZ. On firing, flash from this cartridge passes through the flash hole in the tail plug and ignites the primary cartridge in the perforated tail tube which in turn ignites the augmenting cartridges in the fins by way of the perforations. The resulting pressure projects the bomb.

Note.—In future, to avoid damage to the augmenting cartridges during transport, bombs will be supplied without their augmenting cartridges fitted. Ten augmenting cartridges (in two cardboard tubes) will be packed in each box of five bombs.

To prepare a bomb for firing, fit two augmenting cartridges to each bomb and remove the instruction label. If the bombs are not fired, then, before they are landed, remove the augmenting cartridges, return them to their tube and replace the instruction label.

CHAPTER XIX
PYROTECHNICS

670. Pyrotechnics are used in Naval Service for the following purposes :—

- Signalling and Navigation.
- Illumination.
- Recognition and Identification.
- Targets for Close Range A.A. Weapons.
- Display.

Pyrotechnics for use in aircraft are described in Air Publications.

SIGNALLING AND NAVIGATION.

Rocket, Signal, 1-lb., Service. *Plate 30.*

671. The design and components of the rocket are shown in detail in the illustration. The long stick is attached to the case to keep the axis of the rocket parallel to its trajectory; the metal socket is glued to the outside of the case and is also bound with twine or glued tape.

The rocket may be fired from a Machine, Rocket, Signal or a Rocket, Upright, Firing.

The upper cylinder, of rolled paper, contains 28 white stars. A small charge of rocket composition or sulphurless mealed powder is inserted between the clay plug and the adjacent tier of stars to assist lighting-up and ejection. The head of the upper cylinder is closed with a paper disc, which is covered with a millboard cone; the other end is secured to the case and the joint is sealed with paper strips.

The case, of rolled paper, is choked near the base to form a vent. It is threaded internally below the choke to receive the plug; if closed by a millboard disc it is left plain. The charge of rocket composition is filled so as to leave a cavity.

Action.

672. When the wooden plug is removed the vent is exposed and the Rocket is ready to be projected. On firing, combustion of the powder priming in the choke ignites the Rocket composition. The ignition of the composition causes a pressure of gas in the rocket, and this gas, escaping through the vent, presses against the air and propels the rocket. When the greater part of the Rocket composition has burned, combustion spreads through the cavity and the priming hole in the clay filling to the Rocket composition in the upper cylinder and the stars are ignited and ejected. Ejection takes place at a height of about 900 feet, and the stars burn for approximately five seconds.

The Rocket is painted drab. A white instructional label is secured round the case.

673. *Marking.*—The following information is stencilled on the upper cylinder and stamped on the plug :—

- Contractor's initials or trade mark.
- Date of manufacture.
- Lot No.

When fired from a Machine, Rocket, Signal, the rocket is ignited by a Friction Tube (*see paragraph 697*). When fired from an Upright, Firing Rocket, the vent of the Rocket is ignited with a portfire.

Packing.—Each rocket is packed in a tin cylinder, the cylinders are supplied in wooden packages.

The wooden screw plug in the vent prevents self-propulsion in the event of accidental ignition; a rocket so fitted will burst on ignition. The wooden plug must be removed when the rocket is required for use. As a wartime expedient the wooden plug has been replaced by a cardboard disc secured by a paper seal. Should the paper seal be broken, the rocket must be re-sealed in its tin and kept in a dry place on deck for "first use"; it must not be re-stowed in a magazine. When preparing a rocket for use in "Uprights," the paper seal should not be broken until it is intended to fire the rocket.

Rocket, Signal, 1-lb., Red or Green.

674. The action of these rockets is similar to the 1-lb. Service Rocket, and they are fired from a Rocket, Upright, Firing. The upper cylinder is larger than that of the Service Rocket and has a round cap. The stars are packed with and ignited by quick-match which serves to open the head and scatter the stars. A sulphurless mealed powder is sprinkled amongst the stars to assist ignition.

The rocket case is painted a drab colour and the upper cylinder the colour of the stars it contains. The number of stars differs for the various marks of each colour.

Cartridges, Signal, 1-inch and 1½-inch. *Plate 30.*

675. These cartridges are fired from a Pistol Signal, 1-inch or 1½-inch.

Each cartridge contains a single star, Red, Green or White.

For identification a paper label is attached to the closing disc and on it is printed the colour of the particular star ; an appropriately coloured band is also on the body near the mouth. Formerly, for identification at night, the rims of cases were milled all round for a Red star, plain for a Green star, and milled half way round for a White star.

On Cartridges, Signal, 1-inch only these means of identification are being superseded by an embossed impression on a metal disc at the mouth. A cross represents a Red star, a triangle a Green star and a circle a White star ; cartridges so marked have no paper label affixed to the closing disc.

Cartridges are packed in brown paper packets in metal lined cases labelled to indicate the colour of the stars.

1-inch are packed 4 in a wrapper ; 120 cartridges in a $\frac{1}{4}$ M.L. case.

1 $\frac{1}{2}$ -inch are packed 2 in a wrapper ; 66 cartridges in a $\frac{1}{4}$ M.L. case.

The 1-inch and the 1 $\frac{1}{2}$ -inch cartridges are similar in design, although there are variations in construction for the different colours in each size.

The Cartridge, Signal, 1-inch, Red described below, may be taken as typical.

Cartridge, Signal, 1-inch. Red, Mark XIV.T. *Plate 30.*

676. The case is of wax-impregnated paper and contains the propellant charge, a star with igniter pellet, a supporting felt washer for the star, and paper and millboard closing discs.

Action.

On firing, the propellant ignites and ejects the star, which burns brightly.

Where conditions permit, the pistol should be lashed to a support above the heads of persons in the vicinity and fired by using a lanyard. When this is not possible, the pistol should be held at full arm's length above the head of the firer, who should keep his head down ; alternatively, the pistol may be fired from a clamp, as illustrated in O.U.5440, Visual Material Handbook.

In all conditions of firing personnel should stand well clear.

Flare, Signal. *Plate 30.*

677. This flare has a rolled paper body with a handle of wood or rolled paper. The body is charged with flare composition topped with priming and match composition. Above the match composition are a millboard washer, a disc and a "tear-off" tape, which are covered by a brown paper disc. If the handle is of wood, a leatherboard cup is fitted at its base ; the cup is coated with striker composition and secured by a lead capsule and a "tear-off" tape. If the handle is of paper, a wooden plug covered with striker composition is inserted in the base.

Action.

678. Remove the leatherboard cup (by pulling off its "tear-off" tape) or the wooden plug, whichever is fitted. Pull off the "tear-off" tape at the head. Rub the leatherboard cup or wooden plug against the match composition in the head and the Flare composition will become ignited ; the action is similar to striking a match against its box. The burning Flare must be held at full arm's length above the head.

Flame, Float, Delay. Mark I. *Plate 31.*

679. The Flame Float is used for navigational purposes by Aircraft Carriers.

There is a delay of approximately 15 minutes between the time of igniting the safety fuze and the ignition of the Flame Signal. The Flame Signal will burn for approximately 6 minutes after its ignition.

The body, of steel, is cylindrical, and has two chambers. The upper is a buoyancy chamber ; the lower receives the base plate which holds the firing mechanism and a steel container filled with flame producing composition (amorphous phosphorus). The central tube passes from the lower chamber through the buoyancy chamber ; the chamber is sealed with a thin lead tin-foil disc ; the disc is capable of rupture under the gas pressure generated by the Float.

The firing mechanism comprises a striker, spring, cut-down 9 mm. cartridge case and a length of No. 18 safety fuze. The fuze ensures a delay between the time of firing and the ignition of the Flame Signal. The striker is pre-cocked and held by a hand-operated forked plate placed beneath its head. Accidental removal of this plate is prevented by a safety cover which is screwed over the striker mounting.

Action.

680. Puncture the white disc on the side of the float with the piercing tool provided. Unscrew the safety cover and pull the loop of the pull-off forked plate. This releases the striker which fires the cartridge cap and ignites the safety fuze. After the requisite delay the fuze ignites the priming and the flame producing composition in the container and a flame signal is emitted from the central tube.

The Float should be thrown overboard after any desired interval of time less than 15 minutes, after that it will start flaming.

CH. XIX.

ILLUMINATION.

Rocket, 1-lb. Magnesium Star.

681. This rocket has a paper body with magnesium stars packed into the head. It is fired by a pull-off friction arrangement which ignites a Bickford delay fuze. As this type of ignition is liable to failure a portfire or other means of igniting the rocket should always be available. Exposure to wet will quickly render these rockets useless and the number kept for ready-use should be restricted to one, if practicable; and this should be kept as dry as possible. After exposure to the weather for a week rockets should be regarded as unserviceable and thrown overboard or returned to a Depot for destruction. Present supplies are in non-watertight packages; care to keep them dry is therefore very necessary.

The rocket is fired from a Rocket, Upright, Firing.

2-inch Rocket Flare.

682. See Chapter XVI, Rocket-Projected Devices, para. 598.

Rocket, Illuminating, 9-lbs. (Snowflake.)

683. See Chapter XVI, Rocket-Projected Devices, para. 603.

Projectiles, Illuminating, Nos. 1 and 2.

684. See Chapter XVIII, Holman Projectors, para. 650.

RECOGNITION AND IDENTIFICATION.

Submarine Smoke Candles.

685. Smoke Candles are discharged from the signal ejector of a submerged submarine. The action of sea water on calcium phosphide generates flame and smoke, and these are emitted from the mouth of a central tube when the candle reaches the surface.

On the candle being projected the base plate remains in the ejector and may be used again.

686. Burning is usually in two periods:—

- (i) a period of efficient burning when the smoke is emitted in considerable volume and density;
- (ii) a period of inefficient burning when a thin wisp of smoke is emitted.

After the period of efficient burning the flame and smoke become greatly reduced owing to the action of the water admitted while the candle is rising to the surface. If the wave action is such as to cause intermittent entry of additional water while the candle is floating, the flame and smoke will be stimulated. In very calm water this will not occur and the candle will burn very feebly for some time.

Candle, Smoke, White. Mark I. Plate 31.

687. This candle is for use in shallow water. The tin-plate body has two compartments, the smoke generating chamber containing calcium phosphide and the buoyancy chamber. The central smoke emission tube passes from the smoke generating chamber through the buoyancy chamber and is sealed with a plug. A safety pin is fitted through the central tube and plug. The base plate is supplied separately and is attached to the plug by a securing pin immediately before loading. When the base plate is attached the safety pin is withdrawn and the candle is loaded into the ejector tube. The design and components are shown in detail in the illustration.

If the candle is removed from the ejector instead of being fired the safety pin must be replaced at once; care must be taken not to separate the candle and the base plate unless the safety pin is in position.

Action.

688. On firing, the base plate and the plug remain in the ejector. After leaving the ejector the candle turns upside down and rises to the surface. The severance of the plug from the central tube allows sea water to enter the tube and reach the calcium phosphide. Flame and smoke are generated and are emitted from the mouth of the tube when the candle reaches the surface.

TARGETS FOR CLOSE RANGE A.A. WEAPONS.

Rocket, Target, Practice. 1-lb., Marks I* and II. Plate 31.

689. This rocket provides a target for firing practice for close range A.A. weapons. It houses a parachute (dyed blood red) to which a stabilising weight of clay or glass is attached. The head is closed by a wooden conical cap. The choke end of the rocket is closed by a paper disc pasted over the end of the body.

The igniting arrangement consists of a piece of No. 11 safety fuze, one end of which passes through the side of the body into the choke. The end of the fuze is ignited by the match attached, for convenience of operation, to the body.

The rocket is fired from a Machine-Rocket, Signal or a Rocket, Upright, Firing. On reaching the vertex of its flight a small powder burster expels the parachute and its weight.

CH. XIX.

ILLUMINATION.

Rocket, 1-lb. Magnesium Star.

681. This rocket has a paper body with magnesium stars packed into the head. It is fired by a pull-off friction arrangement which ignites a Bickford delay fuze. As this type of ignition is liable

Page 102. After paragraph 684 insert new paragraphs 685-688 attached :—

RESTRICTED**RECOGNITION AND IDENTIFICATION SIGNALS****Grenade, Signal, No. 65**

685A. The Grenade No. 65 is a recognition signal which can be fired—

- (a) from the upper deck of surface craft and surfaced submarines—from a pistol, grenade, 2½-inch (this is a pistol, signal, 1½-inch, modified by fitting a discharger cup) ;
- (b) from submerged submarines—the grenade is loaded into a float, signal, submerged, and fired from the underwater signal ejector. On reaching the surface the bursting charge of the float is exploded and the grenade is ignited and projected into the air.

685B. To ensure correct insertion into the discharger cup of the pistol or the grenade cup of the float, the top end is marked "LOAD INTO DISCHARGER THIS END UPWARDS", and a circle is embossed for purposes of identification at night.

Action

686. The flash on discharge of the pistol or from the bursting charge of the float, signal, submerged, ignites the priming and flare compositions. The burning grenade can be projected to a height of 150 feet.

Instructions and Notes concerning the use of Grenade, No. 65, in the Pistol, Grenade, 2½-inch :—

687. (a) The pistol must be secured at 70 degrees elevation in a quick-acting bracket or latch securing to the ship's structure. The pistol must never be fired by hand.

(b) Break the breech of the pistol, insert a cartridge and close the breech.

(c) Remove the rubber cover from the pistol and insert the grenade (legend up) in the discharger cup and replace the rubber cover.

(d) Do not cock the pistol until necessary.

(e) The rubber cover should always be in place over the mouth of the discharger cup whenever the pistol is shipped (whether it be loaded or not) to exclude water. Firing with a flooded pistol may burst the pistol or cause the failure or premature of the signal.

(f) the pistol can be fired safely with the rubber cover on and it is preferable to do this rather than to remove the cover and risk rain or spray.

(g) If there is no time to unload the pistol before diving, the cartridge and grenade are to be thrown overboard after surfacing.

(h) The pistol should be cleaned after every 20 rounds to remove gunpowder residue from behind the extractor, boiling the parts in fresh water if necessary (this should normally be done in depot ship).

(i) The rubber cover should be replaced by a new one whenever it shows signs of deterioration, wear or stretching.

Flare, Identification

688A. This is an identification signal for use between submarines and aircraft. The body is made of steel and contains a flare candle. Two brackets are fitted to the exterior so that the flare may be attached to a ship's structure for firing. The head is closed by a diaphragm and the base by a closing cup. The firing mechanism, which is screwed into the side of the head and parallel to the body, consists of a striker, clutch, spring, 0.410-in. cartridge cap, gunpowder pellet and a firing lanyard. A safety pin with a short lanyard attached passes through the firing mechanism and is secured by a copper wire.

Action

688B. When the flare is secured for firing, the safety pin is removed by pulling its lanyard and breaking the copper wire. The firing lanyard is then pulled and the spring is compressed; when the spring is fully compressed the clutch opens and releases the striker which flies forward under the action of the spring and fires the cartridge cap. The flash from the cap ignites the gunpowder pellet; the flash from the gunpowder pellet passes down the tube and ignites the flare candle. The pressure generated blows off the sealing disc in the head of the flare and the flare burns and gives the pre-arranged signal. The flare candles are various colours and are identified by the type number which is stencilled on the body of the flare.

(G.8290/54.—Amendment No. 24)

690. The difference between the Mark II and the Mark I* rocket is that the Mark II has a cotton parachute whereas the Mark I* has a paper one.

Mark II and Mark I* rockets are interchangeable.

INITIATORS.

691. The following are used as initiators for various types of pyrotechnics:—

Portfires.
Quick-match.
Slow-match.
Light, Short G.S.
Friction Tubes.

Portfire.

692. A Portfire is used for igniting purposes. It consists of a cylinder, 16½-inches long and ¾-inch in diameter, made of stout brown paper pasted, rolled and turned in at one end to form a bottom. A holder is supplied. The cylinder is filled with portfire composition in the form of pellets. A small hole is bored in the top pellet and primed with mealed powder. A portfire may be lit by a slow-match or by any other handy means, and as a rule cannot be extinguished by water. It will burn for about 8 minutes. To put it out, cut off the burning end.

Quick-Match.

693. This is used particularly as a priming. It is made of cotton wick soaked in a mixed solution of mealed powder and gum and dusted over with mealed powder before it is quite dry. When not enclosed it burns at the rate of one yard in 15 to 35 seconds. When enclosed it burns almost instantaneously.

Slow-Match.

694. This is used for keeping a light going in conditions where matches cannot be used. It is made of pure hemp slightly twisted and boiled in a ley of water and wet ashes. It may also be made by boiling in a solution of 8 ozs. of saltpetre to 1 gallon of water. It burns at the rate of one yard in eight hours. About four yards of it go to the pound, and it should be demanded by weight.

Light, Short, G.S.

695. This light is used for igniting purposes. It consists of a paper cylinder containing a column of light-giving composition. The top of the composition is covered with a primed cambric cotton disc, smeared with igniting composition, covered and protected by a millboard disc and a paper cap on which is glued a piece of tape for stripping purposes. At the bottom of the composition is a plug of clay. A beechwood handle is inserted into the bottom of the cylinder and bears against the clay plug. The handle is secured to the cylinder by shellac and is recessed at the lower end and fitted with a wooden plug. The top end of the wooden plug is coated with igniting composition. The light burns for about 2 minutes. The cylinder is painted drab with "Light, Short, G.S.," and the Mark is stencilled in white on the side.

Action.

696. To ignite the light, tear off the disc and pull out the plug. Draw the primed end of the plug lightly across the prepared surface, holding the light so that it points away from the body. On no account is the prepared surface to be *struck* with the plug.

Friction Tube.

697. Friction Tubes are used to ignite rockets fired from a Machine, Rocket, Signal. The Friction Tube has a cylindrical body of solid drawn copper. About ¼-inch below the head a bulge in the side of the tube, with a small hole opposite, forms a seating for the crown of a nib piece. The nib piece has a small fire-hole in its underside and is soldered in. The tube is filled with G.20 powder from nib piece to mouth and is closed with a cork plug. The friction bar, which fits into the nib piece, is roughened at the sides, slightly twisted at the ends and smeared with a priming composition. The nib piece is pressed on to the sides of the friction bar and the joint is sealed with shellac varnish. The projecting part of the friction bar has an eye into which the hook of the rocket machine or a lanyard is fitted.

Action.

698. The lanyard is stretched and then pulled sharply to withdraw the friction bar. The resulting flash ignites the priming composition which in turn ignites the G.20 powder and the tube is fired.

FIREWORKS BOXES.

699. Signal Rockets, 1-lb. Service, Portfires, Short Lights and Red Flares, are supplied to ships packed in Fireworks Boxes, large and small. Rockets, 1-lb. Red and Green, Flares, Green and Cartridges, Signal, 1-inch, are supplied in separate containers.

CH. XIX.

Fireworks boxes contain the following stores:—

<i>Stores</i>	<i>Large Box</i>	<i>Small Box</i>
Lights, short	12	8
Portfires, common	20	10
Rockets, Signal, 1-lb. (Service)	30	12
Flares, Signal, Red	8	4

Fireworks are stowed in their packages in the firework magazine or firework tank, whichever is fitted. They may also be stowed in shell rooms provided no other explosive except Classification Group V is stowed therein.

70. The following firework boxes are fitted on deck or elsewhere and are replenished from the firework magazine or tank:—

- (i) Night signal box.
- (ii) Sea boat box.
- (iii) Boats magazines.

Night Signal Box.

701. These boxes are packed with fireworks for signalling, and contain:—

- 3 signal rockets in tin cylinders.
- 24 friction tubes.
- 2 short lights.
- 1 pistol, signal, 1-inch.
- 18 1-inch signal cartridges, 6 of each colour.

The boxes are provided with a lock and key and are to be placed where they are readily accessible as they may be required at a moment's notice. The rocket machine rigged with a rocket and stick in it ready for use and some spare sticks are always to be kept close to the box. Two boxes are supplied to flag ships, one to other ships.

Sea Boat Box.

702. One box is supplied for each sea boat and contains:—

- 4 short lights.
- 1 pistol, signal, 1-inch.
- 24 1-inch signal cartridges, 6 green, 6 red and 12 white.

The Gunner is to report to the Captain on proceeding to sea that a properly equipped Sea Boat's box is in each sea boat. Every evening at sea he will satisfy himself that it is there and report accordingly.

Boat's Magazines.

703. These boxes are packed with a ready use supply of ammunition and fireworks in case of prolonged duty in a boat armed with Q.F. or machine guns or rifles only.

There are two types in the service, namely:—

- (i) A Boat's Magazine which contains:—

- 204 rounds of pistol ammunition.
- 1 leather pouch (cases, cartridge, 204 rounds, pistol).
- 1 strap for ditto.
- 1 key for metal-lined case.
- 1-lb. slow-match.
- 2 portfires.
- 2 1-lb. signal rockets.

These magazines will only be supplied until stocks are exhausted, when they will be superseded by Gig's Magazines for all services.

- (ii) A Gig's Magazine contains:—

- 96 rounds of pistol ammunition in a pouch with a strap.
- 1 signal rocket.
- 1 portfire.
- 1-lb. slow-match.
- 1 key for metal-lined case.

CHAPTER XX

LINE-CARRYING ROCKETS AND LINE-THROWING GUNS

LINE-CARRYING ROCKETS.**Rocket, Line-Carrying, Schermuly, 2-lb.** *Plate 31.*

710. This rocket is used for carrying a line and is fired from a Pistol, Rocket, Line-Carrying Schermuly. The pistol cartridge contains 18 grains of G.20 powder (Cartridge, Rocket, Line-Carrying, Schermuly). On firing, the cartridge ignites the rocket composition and ejects the rocket from the muzzle of the pistol.

The rocket is of steel with a line attached to its tail. Its design and components are shown in the illustration.

The steel rod, 17-inches long, is secured to the outside of the tube by riveting or stabbing. A special $\frac{1}{4}$ -inch or $\frac{3}{8}$ -inch line is attached to the rear end of the rod.

Separate boxes are provided for $\frac{1}{4}$ -inch and $\frac{3}{8}$ -inch lines. Care must be taken to see that the box used is the correct one for the line being stowed in it.

Instructions for Use.

711. (i) See that the line is properly coiled down for running.
- (ii) Make the inboard end fast in the ship.
- (iii) Take the free end and bend it on to the eye of the tail wire of the rocket.
- (iv) Grasp the pistol with the left hand by the "barrel handle" and hold it horizontally in front of the body, muzzle to the front and the breech open.
- (v) Take the rocket in the right hand and place it home in the muzzle of the pistol.
- (vi) Insert a cartridge with the right hand and close the breech by bringing the pistol grip up to the barrel.
- (vii) Elevate the pistol to an angle of 30°, hold it firmly, close to the body, with the left hand at the barrel handle and the right hand at the pistol grip.
- (viii) Cock the pistol with the thumb of the right hand. It is then ready for firing.
- (ix) See that the range is clear and that the line is clear outside the left arm.
- (x) Hold the pistol at an elevation of 20° and fire it.

With no wind the range using a $\frac{1}{4}$ -inch line is approximately 200 yards; using a $\frac{3}{8}$ -inch line it is 150 yards.

Rocket, Line-Carrying, Schermuly, 1-lb.

712. This rocket is similar to but smaller than the 2 lb. rocket. With no wind it has a range of 115 yards with a $\frac{1}{4}$ -inch line and 70 yards with a $\frac{3}{8}$ -inch line.

Rocket, Line-Carrying, Schermuly, 6-lb.

712A. This rocket has a $\frac{1}{4}$ -inch line and a range of 300-350 yards. It is for supply to Commissioned Rescue Tugs. A special Schermuly Pistol 6-lb. and cartridges are supplied.

LINE-THROWING GUNS.

713. The two types of line-throwing gun in the Service are the Line-Thrower, Shoulder, Coston (which is obsolescent) and the Rifle, M.L.E. (0.303-inch, long).

Line-Thrower, Shoulder, Coston.

714. The Coston gun has a short barrel and the projectile is loaded into the muzzle. A special breech-loading blank cartridge is supplied for the gun (Cartridge, S.A. Remington, U.M.C., 50/70, blank). The projectile consists of a round mild steel bar with a line attached. Detailed instructions for assembling, loading and firing are issued with each gun and must be followed. Briefly summarised, these are:—

- (i) Coil down the line free for running in the box provided or in a Clarkson's case.
- (ii) Attach the line to the projectile. If a wire tail is not provided, the line should be wetted within three feet of the projectile to prevent its being burned by the flash of the gun.
- (iii) Load the projectile into the muzzle of the gun.
- (iv) Load the blank cartridge into the breech.
- (v) Rest the butt of the gun on the deck or against a stanchion at an elevation of about 20° and fire it.
- (vi) The chamber and empty cartridge case should be inspected after each round. If the cartridge case is split any piece of brass remaining in the chamber should be removed.

CH. XX.

Rifle, M.L.E. (0.303-inch, long).

715. This rifle has superseded the Coston Gun. The projectile is loaded into the muzzle and a Cartridge S.A. Rifle Grenade, 0.303-inch Cordite H, is used to fire the projectile.

Detailed instructions for assembling, loading and firing are issued with each rifle and must be followed. Briefly summarised, these are :—

- (i) Attach the line to the projectile and coil it down as for the Coston gun.
- (ii) Load the projectile up to its collar in the muzzle of the rifle.
- (iii) Load the blank cartridge into the breech.
- (iv) Fire the rifle from the shoulder at an elevation of about 20° . On firing, the face should be kept clear of the stock; the trigger should be pulled with the tip of the finger and the part of the hand between the first finger and thumb should be kept well clear of the bolt.
- (v) If a missfire occurs the rifle should be unloaded. The bore should then be examined to see that it is clear and so that the rifle is ready for reloading and firing again. This will safeguard against the possibility of there having been a "puff shot."

716-719.

CHAPTER XXI

AIRCRAFT BOMBS AND THEIR COMPONENTS

GENERAL REMARKS.

720. This chapter deals briefly with aircraft bombs and their components. Air Publications and Naval Magazine and Explosive Regulations must be consulted before any attempt is made to fuze or unfuze a bomb.

The regulations to be observed on board ship with regard to aircraft bombs, and their components, and the responsibilities of the Gunnery Officer and Air Gunnery Officer are set out in the Naval Magazine and Explosive Regulations.

FACTORS INFLUENCING DESIGN.

The shape of aircraft bombs is determined to a great extent by the need to achieve steadiness in flight. Bombs are not required to withstand stresses such as are set up on the discharge of a shell from a gun and their walls are not made of so thick metal. They have a larger capacity than a shell of the same weight designed for a similar purpose, but they have less penetrative power.

EXPLODER SYSTEM.

721. The "relay" system—detonator, exploder and main filling—is fitted for the detonation of H.E. bombs. The detonator is fitted in conjunction with a pistol or is contained in a fuze which is in effect a combined pistol and detonator. The exploder (C.E. or T.N.T.) is fitted in a pocket in the main filling.

The detonator or fuze can be arranged to give a delay, if required, between the time the bomb strikes the target and the detonation of the main filling. It is convenient to describe a bomb as "fuzed" to denote that it is fitted ready for use, whether the actual arrangements consist of a fuze or of a pistol and detonator.

FUZES FOR H.E. BOMBS. Plate 33.

722. Fuzes embody Safety Arrangements, Initiating Detonators, Delay Increments and charges known as "Magazines." When a bomb is released from an aircraft the vanes are freed by the removal of some form of device and their rotation "arms" the fuze. When handling fuzes care must be taken to ensure that they are not accidentally brought to the "armed" or dangerous condition. Bombs returned from a flight may have a fuze which has become armed and special precautions are always necessary.

PISTOLS FOR H.E. BOMBS.

723. In the majority of H.E. bombs a system of simplified fuzing has been adopted, and the mechanical and explosive parts of the fuze are provided and inserted in the bomb as separate components, i.e., the pistol is purely mechanical and the detonator contains the delay increments and magazine. With both tail and nose pistols it is important to ensure that the safety arrangements are correctly in position when fitted.

Tail Pistols. Plate 33.

724. The tail pistol consists of a pistol body and a striker held in position by a creep spring. When in the "safe" position the striker is also retained by an arming nut screwed on to its rear end. On release of the bomb the nut is screwed off the striker by the forked connecting rod and arming vanes forming part of the tail unit. When the nut is unscrewed the striker is retained by the creep spring and the pistol is then "armed." On deceleration of the bomb due to impact, the striker will fly forward against the weight of the spring on to the detonator. Typical examples of tail pistols are the No. 30, which has a pointed striker and the No. 28, which has a blunt striker with a small point. Each is used with its own special type of detonator.

Nose Pistols.

725. The nose pistol consists of a pistol body and a striker held in position by a shear wire. The forward end of the striker has a "mushroom" head which, on impact, drives the striker to the rear, breaking the shear wire. The mushroom head is protected by a cap. In some types of pistol the arming vane of the cap screws off on release of the bomb, and in other types it is released by other means.

SAFETY ARRANGEMENTS OF FUZES AND PISTOLS.

726. Fuzes and Pistols have arrangements designed to render the bomb harmless in the event of a crash landing, accidental dropping or jettisoning over friendly territory. An arming vane (whose action in fuzes is to release a shutter and bring the detonator into line with the striker) is usually

CH. XXI.

employed for this purpose, but fuzing attachments may be fitted in some small bombs. In addition to these arrangements a Shearing Wire or a Creep Spring is usually fitted.

727. The following devices may be fitted to prevent the arming vane revolving before the bomb is released :—

- (i) A Transit Pin which is removed before the aircraft takes off or, alternatively, a Safety Fork which may, or may not, be removed before the aircraft takes off, depending on the type of bomb carrier.
- (ii) A wire rove through the arming vane and kept in position by spring clips (or, in older designs, a stop attached to a clip which fits over the arming spindle). The wire (or clip) is connected to the bomb carrier, and the means of releasing the bomb provides for withdrawal, unless it is required to drop the bomb "safe."

Fuzing Attachments. With some small bombs (not fitted with arming vanes) attachments are fitted to the bomb carrier to keep the bomb in a safe condition while it is on the carrier. As soon as the bomb is released it becomes "live." Such bombs cannot be jettisoned "safe."

Shearing Wires and Creep Springs. In addition to the arming vane the striker is held off the detonator by a shearing wire or a creep spring whose strength is designed to suit operational use but provides some safety if the bomb is accidentally dropped a few feet.

DETONATORS FOR H.E. BOMBS.

728. A bomb detonator contains a small amount of very violent high explosive which is initiated by the striker on the pistol impinging on a percussion cap.

The two main types are :—

- (1) "Sensitive"—suitable for use with a sharp pointed striker, and
- (2) "Anvil"—for use with pistols having a blunt striker.

The external dimensions of each type are the same. Except in "instantaneous detonators," a column of delay composition of a suitable burning length is inserted between the cap of the detonator and the "initiator" or main filling of the detonator. Detonators have the length of delay written in the head and each type has a distinguishing colour band. Weights of explosive are given in Notes on Naval Guns and Armament Stores.

Detonator-Burster.

729. This is a special detonator for use in practice bombs. In addition to acting as an initiator it carries a charge powerful enough to open the bomb case.

BOMB TAILS.

730. Tails for bombs of 100-lbs. and heavier are supplied as separate components; they are not assembled to bombs until required for service. Tails are designed to be readily attached to the bomb by turnbuckle clips; these clips must be fastened to prevent the tail becoming displaced. Tails used in conjunction with pistols have arming vanes which are freed by the withdrawal of a spring safety clip when the bomb is released. The vanes revolve the arming spindle at whose inner end is a fork, which engages a second fork on the arming nut of the pistol.

Tails used in conjunction with fuzes do not require arming vanes as these are components of the fuze.

TYPES OF BOMBS.

731. Bombs may be classified broadly in the following groups :—

- | | | |
|------------|---|---|
| H.E. Bombs | { | <ol style="list-style-type: none"> (1) Semi-armour-piercing (S.A.P.) or armour-piercing (A.P.) (2) General Purpose (G.P.) (3) Medium Capacity (M.C.) (4) Anti-submarine (A.S.) (5) Anti-personnel. (6) Incendiary. (7) Practice. (8) Drill. |
|------------|---|---|

S.A.P. (Plate 32) and A.P. Bombs. Examples—250-lbs. and 500-lbs. S.A.P.

732. S.A.P. bombs are designed for attack on armour plate of ships or on other highly resistant targets. They are made of good quality steel, heat treated to give a hard penetrative point and have tough walls. The shape is streamlined to offer low resistance to air flow and to obtain high striking velocity. Their capacity is about 15 per cent. The damage caused will be due to fragmentation rather than blast. Detonation is initiated by a pistol and detonator or by a fuze in the tail. The fuze or detonator embodies a delay sufficient to allow perforation of an armoured deck before detonation.

Armour-Piercing bombs are similar to S.A.P. bombs, but have more heavily built heads and a relatively smaller capacity.

General Purpose Bombs. Example 250-lbs. G.P.

733. These bombs are used for attack on a variety of targets against which the perforating qualities of S.A.P. bombs are not essential. They have a thinner body than the S.A.P. bomb and a

capacity of approximately 25 per cent. The blast effect is greater than with S.A.P., but the main damage is caused by fragmentation. A pistol and detonator is inserted in either the nose or the tail of the bomb. A nose pistol must function before it is broken or crushed by impact, and for this reason an instantaneous detonator is fitted with it. This arrangement reduces the crater effect. When a delay is required the suitable detonator should be used along with a tail pistol.

Medium Capacity Bombs. Example, 500-lbs. M.C. Plate 32.

734. These bombs have a greater capacity than G.P. bombs; and consequently have an increased blast effect and produce smaller fragments. Their pistol and detonator arrangements are similar to those of G.P. bombs.

Anti-Submarine Bombs. Example, 100-lbs. A.S.

735. These are special-purpose bombs as their name implies, but they may be suitable for other targets if a greater blast effect than that given by G.P. bombs is required. Depending on type, either a nose fuze or a tail pistol and detonator may be employed.

Anti-Personnel Bombs.

736. These are small bombs of 20-lbs. to 40-lbs. designed to give a large number of small fragments on detonation. The 40-lb. G.P. bomb is suitable for this purpose; it is fitted with a nose pistol and detonator only, but in other respects is similar to the larger G.P. bombs. A parachute attachment may be fitted.

Incendiary Bombs.

737. The main filling of these bombs is incendiary. In the 25-lb. Incendiary bomb the pistol is built into the bomb at the tail end. Other types have a nose fuze.

PRACTICE BOMBS. Plate 32.

738. These are small bombs (about 10-lbs.). They have a cast-iron or plastic moulded nose screwed to a container filled with either a smoke composition for day practice or a flash or flare composition for night practice. Night practice bombs are supplied filled. Day practice bombs may be supplied without the smoke filling, which is issued separately. The bomb is filled locally before use. The pistol is built into the bomb, and on impact the striker shears a wire and fires a detonator-burster.

Drill Bombs.

739. Any of the above types of bomb are supplied for instructional and drill purposes and differ only from service bombs in that their filling is inert.

Markings on Aircraft Bombs.

740. Stencil markings on the bomb give the following information :—

- (i) Nomenclature and mark.
- (ii) Gross weight.
- (iii) Where filled and date of filling.
- (iv) Lot Number.
- (v) Date and place of last examination.
- (vi) Design number of method of filling of Bomb (where applicable).

741. Colour markings are used as follows :—

- (i) H.E. bombs are coloured green (earlier bombs were yellow).
- (ii) A red band near the nose indicates that the bomb is filled.
- (iii) A white ring adjacent to the red identifies an S.A.P. bomb.
- (iv) Two white rings, one either side of the red, denotes A.P.
- (v) A plain green band denotes a T.N.T. filling—"T.N.T." is stenciled on or near the band.
- (vi) A criss-crossed green band, with a fraction below, denotes an amatol filling of high grade.
- (vii) A plain green band, with a numeral above and a fraction below, denotes an amatol filling of low grade.
- (viii) Incendiary bombs are painted a dull red.
- (ix) Practice bombs are painted white; two green bands denote a smoke composition filling and two black bands a flash composition.
- (x) Drill bombs are painted black with a yellow band.

Note.—The new system of colour marking, common to all Services, to denote the explosive filling will be found in B.R. 1202.

CHAPTER XXII

AMMUNITION PACKAGES

SECTION 1.—GENERAL REMARKS

745. For the purpose of this chapter Ammunition Packages are grouped as follows :—

- (1) Packages stowed on board with their ammunition (*e.g.*, Cases for cartridges, B.L. ; Q.F. Cartridge and Ammunition boxes).
- (2) Packages for the transport of ammunition (which are not stowed in the ship).

The weight, dimensions and contents of the various packages are included in "*Notes on Naval Guns and Armament Stores.*"

746. Packages containing ammunition must be handled with great care, and the instructions in the N.M. & E.Rs. carefully observed. Rough usage of packages may result in :—

- (i) Damage to the contents. This may cause missfires, hang-fires or prematures.
- (ii) Loss of air-tightness. This will cause a loss of efficiency.
- (iii) Jamming of lids of cases. This will cause loss of time and possibly a reduction in the rate of fire in action.

747. Ammunition packages must not be raised or lowered quickly. Ample time should be allowed. Embarking and disembarking ammunition should never be treated as an evolution or as a matter of competition between ships. If a package catches or jams in such a way that damage may be caused to it or its handles the package should be set aside and carefully examined ; if there is damage or suspicion of damage, the package must be returned to an Armament Depot for test.

Care must be taken to prevent water getting into packages, particularly packages of aluminium-silicon or galvanised iron ; filled packages should not be exposed to heavy rain.

Packages are rendered weather-tight and air-tight by the use of luting, dermatine rings or rubber rings.

Luting is a thick paste which does not dry easily ; it is placed between metal surfaces or in channels to form an air-tight joint. It is also used to render metal or tin lined cases and cartridge and ammunition boxes water-tight. If possible, luting should be examined at intervals of six months to test its efficiency ; lids of packages are not to be removed specially for this purpose.

Dermatine is a rubber composition ; when a ring of dermatine is pressed into the groove around the lid or opening of certain cases it forms an air-tight seating for a flange.

748. The sealing devices of packages must be examined on embarkation and packages with broken tapes or seals are to be returned to the Naval Armament Depot with a report of the circumstances. When returning filled ammunition packages those with broken seals are to be kept separate and the Armament Depot informed.

CH. XXII—SECTION 2.—PACKAGES STOWED ON BOARD WITH THEIR
AMMUNITION

CASES.

749. Cartridges, B.L., are packed in cylindrical or rectangular flashproof cases of aluminium alloy, steel or brass. The cases are stowed to permit easy access, *i.e.*, so that the contents can be withdrawn without moving the case in its stowage. The abbreviated nomenclature denotes the shape, *e.g.*, "C.E."—Cylindrical "E," "R.N."—Rectangular "N." Cases are usually sealed by affixing two station monogram labels over the joint of lid and body ; some cases have sealing labels fixed over the ends of tapes. "C.E.," first supplies of "C.F." and "R.N." cases have their own individual sealing arrangements.

Cases and certain cartridge and ammunition boxes require metal keys to open and close them. The keys vary in shape according to the type of lid ; they are usually hung in a convenient position in the magazine. A list of keys is set out in *paragraph 772*, with illustrations in the Schedule of Keys on *page 131*.

CASES, POWDER, CYLINDRICAL. Plate 34.

750. Fractional charges for B.L. 14-inch, 15-inch and 16-inch guns are packed in cylindrical cases with the ignited end of the Cartridge, B.L. towards the lid. The cases are of sheet brass or steel, jointed with rivets or welded and strengthened by circular bands. The lid is secured by feathers or lugs taking under recesses in the rim of the case ; it is rendered air-tight by a rubber or dermatine ring. The bottom of the case is strengthened. Cylindrical cases should never be rolled along the deck.

"C.E." Case. Plate 34.

751. This case holds three 1/6 charges for a B.L. 16-inch gun. The case is of brass and strong end rings improve the flashtightness. It has three handles. Cardboard liners provide further anti-flash protection and facilitate the withdrawal of cartridges. (To assist withdrawal the lifting band of the second cartridge is attached to that of the third.) The lid is secured by a locking ring whose six lugs drop into grooves in the end ring. A screwed ring revolves inside the locking ring.

Sealing is effected by two lead alloy seals each passing through a hole in the end ring of the case. The head of the seal bears the monogram of the closing station; the other end is riveted into a countersunk recess in the end ring and impressed with the monogram of the station. The air testing plug is covered with a small brass disc bearing the monogram of the closing station and is soldered in position.

752. *To open.*—Ship the "Key, Case, Magazine, No. 1" over the bar running diametrically across the screwed ring and turn in an anti-clockwise direction until the lugs in the locking ring are in line with the slots in the end ring of the case. Remove the lid. If the locking ring is not moved when the spring catch is in contact with its stop, the catch should be withdrawn and rotation continued until it is again in contact with its stop, when a further attempt to move the locking ring should be made. If the lid is difficult to withdraw when the lugs on the locking ring are in line with the slots in the end ring the "lever, opening, C.E. case" should be used to prise the lid and free the dermatine ring from the joint face.

753. *To close.*—Place the spring catch anti-clockwise to its stop. Insert the lid into the end ring of the case, ship the key and turn in a clockwise direction until the locking ring reaches the limit of its travel. Withdraw the spring catch and continue the rotation until the lid is hard down. The spring catch should be depressed again if more than one revolution is needed to close the case.

"M" Case. Plate 34.

754. This case holds two 1/4 charges for a B.L. 15-inch gun. The case is of brass or steel and has a handle of copper wire covered with leather; later Marks have a metal handle. Strengthened end rings improve the flashtightness; cardboard liners provide further anti-flash protection and facilitate the withdrawal of cartridges. Cases were originally designed with a lid at each end, but were converted by having one end permanently closed; this end is painted blue. The set screw in the end ring at the lid end can be screwed home to prevent the lid falling off during transport. This screw is removed before opening the case and must be readily accessible; during hostilities, all the screws should be removed. There are two small holes in the case and one in the lid and the sealing label is secured by tapes.

755. *To open.*—Remove the set screw (if fitted). Ship the "Key, Case, Powder, Cylindrical 'L' and 'M' No. 4 or 5 or 'M' No. 6" (as supplied) and turn in an anti-clockwise direction until the lugs on the locking ring are visible in the slots in the end ring of the case. Remove the lid. If Key No. 6 is supplied the lid can be lifted clear with it. A lever is provided to assist opening.

756. *To close.*—Place the lid in the mouth of the case so that the lugs on the locking ring enter the inclined grooves in the case. Turn the lid in a clockwise direction using the Key provided. Undue force should not be used, but an airtight joint is essential. The lid is prevented from turning by screwing home the set screw.

"C.F." Case. Plate 34.

757. This case holds two 1/4 charges for a B.L. 14-inch gun. The case is of brass or steel with a solid bottom. It has only one handle. First supplies have a brass body with strengthening bands; modern cases have circumferential corrugations. All "C.F." cases have two locating bands to engage the wriggle bars of the magazine stowage. The case is sealed by affixing two linen station monogram sealing labels on opposite sides over the junction of lid and end ring.

758. *To open.*—Remove the locking pin by pulling the toggle. Ship the "Key, Case, Magazine, No. 4" and turn the locking ring in an anti-clockwise direction. When the lugs on the locking ring are visible in the slots in the end ring of the case, the lid with the locking ring attached will be held on the key by the two spring catches and can be withdrawn from the case.

759. *To close.*—The lines on the locking ring and the lid should be opposite before the lid is shipped on the case. Ship the key on the lid and insert the lugs of the locking ring into the slots in the end ring of the case. Make sure that the slot for the locking pin is opposite the holes in the end ring when the lid is fitted. Turn the locking ring in a clockwise direction until the lid is secured. Before unshipping the key make sure that the locking pin can be inserted in one or other of the holes in the end ring and, if necessary, adjust the position of the locking ring. Unship the key and insert the locking pin, open out the ends of the split pin (locking pin) so that the pin is held in position. Stick a piece of adhesive tape over the wire to keep the toggle in position.

RECTANGULAR CASES. Plate 34.

760. Charges for B.L. guns 8-inch and below and Charges, Aircraft, Catapult, are supplied in rectangular cases of aluminium alloy or sheet brass, corrugated or indented to give strength. The ends are solid and are secured to the body by various means. Wood linings are fitted in some old type cases to prevent irregular fittings in the ends of the cases injuring the cartridges. Wood or cardboard packing pieces in the shape of stools, cylinders, etc., may be supplied for convenience of

BOXES FOR Q.F. AMMUNITION.

773. Boxes for Q.F. separate loading cartridge cases are called "Cartridge Boxes," and boxes for Q.F. fixed ammunition are called "Ammunition Boxes." The boxes are rectangular and are of wood, aluminium alloy or steel. They have various methods of locking. These and other boxes are marked with a code letter to identify the contents; the number after the code letter denotes the series in the class. The code of letters is as follows:—

P.	Projectiles.
F.	Fuzes.
C.	Q.F. cartridge cases and Q.F. fixed ammunition.
B.	Bombs and accessories.
G.	Grenades and accessories.
H.	Small Arms Ammunition (A.S.A.).
M.	Miscellaneous.
T.	Tubes, Vent.

The letter and a number are branded or engraved on each end of the box.

CARTRIDGE BOXES.

774. All cartridge boxes (except C.185) are of teak or other hardwood and are lined with tinned copper or tinned plate. Strengthening bands are fitted as necessary. The handles are of galvanised iron, steel wire rope or grummets with leather or canvas grips. The lid of the older type of box is secured by a locking plate which engages four metal bolts; the plate has an eccentric action and is operated by a rectangular key. The modern box lid is fastened by catch levers which are held down by split pins or by a hasp secured with a turn buckle. Lids are rendered watertight by filling luting into the recess around the top of the lining.

Box, Cartridge, C.23 Mark II. Plate 35.

775. This box holds six cartridges for Q.F. 4-inch, Marks V-V** guns. It is of hardwood and has a metal lining. It is fitted with two wire handles. The lid is secured by four catch levers which are held down by split pins.

Box, Cartridge, C.185. Plate 35.

776. This box holds four cartridges for Q.F. 4.7-inch guns. It is of galvanised steel and its lid screws down on to a rubber or dermatine joint. The two wire handles are at the sides. Three steel diaphragms retain the cartridges in place and a stop (which fits over the bases of the cartridges) prevents lengthwise movement. Tape is threaded through the handle and round the centre pin of the lifting plate and knotted. A linen sealing label is affixed over the knot and the ends of the tape.

777. *To open.*—Turn the handle in the centre of the lid anti-clockwise and remove the lid. Remove the cartridge stop by unscrewing the wing nut in the centre; use Key, Box, Cartridge, No. 2, if necessary. Withdraw the cartridges from the box.

778. *To close.*—Insert the four cartridges in the box and assemble the cartridge stop on the centre spindle. Tighten up the wing nut, using Key No. 2. Assemble the lid and tighten up on the handle in a clockwise direction.

AMMUNITION BOXES.

779. All Ammunition boxes (except C.190) are of teak or hardwood and are lined with tinned copper or tinned plate. The handles are of steel or wire rope with leather grips. The lids are secured by catch levers held in place by split pins.

Ammunition Box C.163. (Plate 35). C.163C, C.273.

780. Each of these boxes holds two rounds of Q.F. 4.7-inch ammunition. They are of hardwood. The lid is secured by two hinges and is fastened by catch levers held down by split pins. A frame with diaphragms and suitable packing pieces is fitted inside to prevent movement of the rounds. Instructions for replacing fired cartridge cases are on the inside of the lid of the box. C.163C and C.273 boxes differ from C.163 only in that they are longer in order to accommodate rounds fitted with No. 211 fuze. The C.163C box is a converted C.163.

Ammunition Box C.190. Plate 35.

781. This box holds 30 rounds for Q.F. 2-pdr., Mark VIII and XIV guns if packed in bulk (the rounds stowing heads and tails) or 28 rounds belted in two articulated belts. The belted rounds will only stow properly in one way, *i.e.*, the way in which they are packed on issue. If unloaded and not used they must be stowed in the same way or the box will be strained on closing. The box is of galvanised steel. The lid is the complete top of the box, and it hinges on and is fastened by two hasps. The loaded box should be kept upright as otherwise the weight of the ammunition may break the internal watertight seal.

Linen monogram sealing labels are affixed over the hasps.

CH. XXII.—SECTION 2.

Ammunition Boxes C.216 and C.219.

782. Ammunition Q.F. 40 mm. (Bofors) is packed in boxes C.216 and C.219. Each is a rectangular steel box with a hinged lid which is fastened by two spring clips. A piece of tarred string is passed through the loop of each clip, knotted on each side, passed through a hole in the stud and secured.

The C.216 box holds 24 rounds in 6 chargers. The C.219 box holds 24 rounds, each in a cardboard container.

CASES, POWDER, METAL OR TIN-LINED.

783. These packages are used for small combustible stores and for boat work. They are of wood and are lined with tinned copper or tinned plate. The lids of the older cases are secured by two screw bolts which are withdrawn by a special key. Lids of the later marks are secured by a brass catch which engages into a slot in the side of the case. There are three sizes of metal and tin lined cases—Whole, Half and Quarter. The following types of ammunition may be contained in these cases:—

Whole Case:—C.118 (Plate 35) and C.122.

- 7,680 rounds 0.303-inch rifle, blank.
- 10 rounds 4.7-inch B.L. or Q.F. blank.
- 130 rounds 4-inch Q.F. blank charges.
- 96 rounds 3.7-inch Q.F. blank charges.

Half Case:—C.119 (Plate 35) and C.123.

- 3,400 rounds 0.303-inch rifle, blank.
- 50 rounds 3-pdr. Q.F., blank, charges 11-oz.
- 37 rounds 6-pdr. Q.F., blank, charges 15-oz.
- 30 rounds 12-pdr., 12-cwt. blank charges.
- 20 rounds 6-pdr. Q.F., blank cartridges.
- 25 rounds 3-pdr. Q.F., blank cartridges.
- 30 rounds 3-inch H.A., blank charges or 4-inch blank reduced charges.
- 5 belts Maxim, filled.
- 168 rounds cartridges, signal, 1½-inch.
- 306 rounds cartridges, signal, 1-inch.

Quarter Case:—C.121 (Plate 35) and C.124.

- 1,200 rounds 0.303-inch rifle, ball, for boats.
- 840 rounds 0.303-inch rifle, ball, in chargers.
- 1,450 rounds 0.303-inch rifle, blank.
- 10,000 rounds 0.22-inch R.F.
- 66 rounds cartridges, signal, 1½-inch.
- 120 rounds cartridges, signal, 1-inch.
- 100 rounds cartridges, safety fuze.

SMALL ARMS AMMUNITION BOXES (A.S.A.).

784. Small Arms Ammunition is provided in various types of wooden boxes which have a tinned plate lining or tinned plate containers. The lining is liable to deteriorate, and the oldest ammunition in the ship must be used first. Linings of all boxes passed up for firing practice should be lifted out and examined. If a lining is defective boxes of the same date are to be examined and, if necessary, the ammunition is to be exchanged at the first opportunity. Exposure to damp may cause discoloration or corrosion of Small Arms cartridge cases in chargers; discoloration does not affect the serviceability of the ammunition, but where there is marked corrosion, the ammunition should be returned at an early opportunity.

The following may be considered typical of A.S.A. boxes generally.

Box A.S.A. G.S., H.4. Plate 35.

785. This is a "Whole" A.S.A. box. The sliding lid is attached to the box with whipcord and is fastened with a split pin. The short length of twisted copper wire attached to the split pin lies in a groove and the seal label is superimposed. A loop of leather is attached to the wire behind the seal; the end of the wire is secured to the lid and the label must be broken before the box can be opened. Galvanised iron wire handles with leather grips are fitted at each end. The lining is of tinned plate with a rip off soldered lid; if the box is opened it cannot be made watertight again except by soldering the lid.

786. The following ammunition may be contained in this type of box:—

- 270 rounds 0.5-inch M.G. ammunition in cartons.
- 96 rounds 1-inch A.R.
- 840 rounds cartridges, S.A., ball, 0.303-inch in chargers.
- 850 rounds cartridges, S.A., ball, 0.303-inch in bandoliers.
- 1,000 rounds cartridges, S.A., ball, 0.303-inch, in cartons.

A.S.A. Box, Half, Naval, H.3. Plate 35.

787. This is a "Half" A.S.A. box. It is smaller but of similar construction to the "Whole" A.S.A. box. It has a galvanised iron wire handle at one end. The lid is secured with a brass split pin which has a T-shaped handle attached. To open—withdraw the split pin, slide back the lid and tear off the cover of the lining.

788. The following ammunition may be contained in this type of box :—

- 828 rounds 0.455-inch revolver.
- 360 rounds 0.303-inch, ball, in chargers.
- 500 rounds 0.303-inch, ball, for maxim gun, in cartons.
- 480 rounds 0.303-inch, ball, for Lewis gun, in cartons.
- 500 rounds 0.303-inch, rifle, blank.
- 350 rounds 0.303-inch, ball, in bandoliers.
- 500 rounds 0.303-inch, tracer.

Box Ammunition, S.A., H.24. Plate 35.

789. This box contains three tin-plate boxes, each of which holds 100 rounds of 0.5-inch cartridges in an articulated belt. The box has two galvanised iron wire handles ; it is closed with two hasps.

Box A.S.A. H.33. Plate 35.

790. This is a special box for 20 mm. British Oerlikon ammunition and it holds 306 rounds in bulk with suitable packing pieces. It has a screw-on lid. The lining is of zinc or tinned plate with a rip off soldered lid.

Boxes, U.S. Oerlikon.

791. There are two types of American manufactured box for American manufactured Oerlikon Ammunition. One type, a wooden box similar to Box A.S.A. H.33, holds 300 rounds. The other type, a steel box somewhat similar to C.216, holds 180 rounds.

Painting of Packages.

792. All packages for gun ammunition, fireworks, torpedo, mining and depth charge explosive components, except those specified in *paragraphs* 793 and 794 below, are painted a STONE colour.

793. Packages painted the following colours contain stores as shown :—

- | | | | | |
|---------------|-----|-----|-----|--|
| GREEN | ... | ... | ... | Target smoke ammunition. |
| GREEN (stain) | ... | ... | ... | A.S.A., bundled, belted, or in cartons or Signal cartridges. |
| BROWN | ... | ... | ... | R.A.F. stores for F.A.A. |
| BROWN (stain) | ... | ... | ... | A.S.A., in chargers. |
| RED | ... | ... | ... | Blank gun ammunition. |
| RED | ... | ... | ... | Cases, transport, detonator and explosive. |
| BLACK | ... | ... | ... | Drill and dummy ammunition. |
| YELLOW | ... | ... | ... | Bombs. |
| GREY | ... | ... | ... | Floats, lachrymatory, and generators. |

794. The following packages are not painted externally or internally apart from special markings :—

- Cases, magazine, made of aluminium-silicon alloy.
- Cases, wood, packing.
- Boxes, projectile.
- Packages of galvanised steel.

The following packages are not painted internally :—

- Cases, magazine.
- Cases, powder, cylindrical, and rectangular.
- Cases, cordite.
- Cases made of galvanised steel.

Special Markings on Packages.

795. The following markings will be found :—

- | | | | | |
|--------------------------------|-----|-----|-----|---|
| TWO RED BANDS | ... | ... | ... | All packages containing explosives except those painted RED. |
| DARK BLUE BANDS | ... | ... | ... | Packages for non-explosive Naval armament stores, including drill and dummy ammunition boxes. |
| PRACTICE (BRIGHT) YELLOW BANDS | ... | ... | ... | Q.F. target smoke ammunition boxes. |
| TWO LIGHT BLUE BANDS | ... | ... | ... | Boxes, cartridge, aircraft, catapult. |
| H.V. | ... | ... | ... | Packages for Q.F. 2-pdr. High Velocity Ammunition. |
| WHITE CROSS | ... | ... | ... | Packages containing a full charge of Flashless cordite (not Star shell charges). |
| GREEN BAR | ... | ... | ... | Packages containing American Propellant. |
| BLACK OR WHITE "ZIG ZAG" | ... | ... | ... | Packages containing H.E. (Radar) Shell. |

CH. XXII.—SECTION 3.

796. To assist rapid identification of the TYPE of projectile contained, all packages for FIXED AMMUNITION are marked with a coloured bar; the bar is painted on the centre cross batten of the lid or on the side bearing the label and on packages for 4-inch and under, where practicable, at an angle to an edge. The colours are as follows:—

LIGHT BLUE	H.A. Practice	} Not applicable to Wartime packages.
DULL YELLOW	Common, H.E.	
PRACTICE (BRIGHT) YELLOW	Practice	
RED	Shrapnel	
WHITE	S.A.P.	
BLACK (broken bar)	C.P.	
BLACK	C.N.F.	

Other Markings.

797. Containers, filled with explosives, which are removed from packages during use and handling in H.M. ships will have the word "Explosive" overprinted in red on the label and will not have red bands (vide paragraph 795). Cardboard containers for cartridges, B.L., and Charges, Aircraft, Catapult are painted with two red bands and will bear an N.13 label.

Wooden packages of new manufacture for fireworks will be fireproofed and the letters "F.P." cut or branded on each end.

One end of "M" cases is painted blue to indicate that this end is permanently closed, as stated above.

Markings on A.S.A. Boxes.

798. Small Arms ammunition in chargers is packed in brown-stained boxes; ammunition in bundles, cartons or belts is packed in green-stained boxes.

A definite indication of the type of ammunition packed and its Mark can only be obtained from the labels; for classification labels are printed in the following distinctive colours:—

Group VI (except blank)	Green on white ground.
Blank	Red on blue ground.
Group IX...	Blue on white ground.
Group XII	Brown on white ground.
Drill or dummy	Black on cerise ground.
Incendiary ammunition...	Red star on white ground.

799. Each type of small arms cartridge up to and including 0.5-inch is identified by a symbol. The symbol is printed on the label in the proper group colour and is overprinted in black with the code letter and, where necessary, the letter indicating the nature of the propellant. The symbols are displayed on large distinguishing labels, one on each side of the box. The labels also contain the following information:—

- The number of rounds.
- Nomenclature.
- Method of packing.
- Date and inspection mark (for new type boxes).

A small distinguishing label is also affixed at each end of the box. On these are printed the symbol and (except ball and signal) the characteristic name, *i.e.*, tracer, armour-piercing, etc.

800. To facilitate identification in the dark of 0.303-inch charger packed ammunition and of 0.303-in. ammunition packed in other than the normal method (*e.g.*, ball and tracer belted together) raised metal letters are affixed to the end of A.S.A. boxes so packed.

The identification letters will be:—

- CC ... charger packed.
- X ... any other unusual packing.

This will be additional to the method at present in force for identifying ammunition in the dark *i.e.*:—

- Belt packed—A "V" shaped wood piece at each end.
- Carton packed—One batten at each end.
- Bandolier packed—No battens at end.

CH. XXII—SECTION 3.—PACKAGES FOR THE TRANSPORT OF AMMUNITION
(WHICH ARE NOT STOWED IN THE SHIP)

BOX, AMMUNITION, Q.F., 4-INCH, MARK XVI* GUNS.**Ammunition Box C.222. Plate 35.**

801. This box holds two rounds of 4-inch, Mark XVI* fixed ammunition. It is of steel and consists of two halves in which cradles to support the rounds are secured. It is jointed longitudinally and the joint is made by a rubber gasket. The package is secured by three wing nuts, the centre nut being drilled and sealed by a wire seal. The wire is threaded through the hole in the small bracket

LABELS



N. 157
28 CARTRIDGES Q.F., 2 PDR., H.V., MK VIII GUN
 (IN LINKS)

CORDITE H.B.E.T. 134-983		FOIL		CASES	PRIMER PERC.	ONE P.V. H.E. MARKED 4 & 13 or T & (but not both)	IGNITER (3-5 SECS. or 7-8 SECS.)	TRADER AND IGNITER (3-5 SECS. or 7-8 SECS.)	FUZZES
LOT	DATE	NO.	T. FOIL						
FILLED	DATE	NO.							
28 LINKS AMMUNITION		NO.							
2 LINKS CONNECTING AMMUNITION		MAKER							
PLUG, BASE, SHELL		DATE							
NO. 14 WK.									
EXPLODER, T.A.T. 3 DRS.									

* EXCEPT WHEN FITTED WITH NO. 15 TRADER AND IGNITER OR PLUGGED

P. Hd

and the wing nut and the ends of the wire are sealed with a lead disc which is impressed with the Station Monogram of the Naval Armament Depot which sealed the package. Two wooden packing pieces are fitted, one at each end of the box. The packing pieces ensure that the tapes of cartridge clips are not caught in the joint of the box and the clips pulled off. Packing pieces must always be kept in place during handling and transport and the tape tucked down before closing the package.

To Open.

802. To prevent damage to the packing pieces the package should be opened as follows:—

Slack back and remove the three wing nuts. Key, Box, Ammunition, No. 3, should be used if necessary. Remove the lid by lifting both handles simultaneously; lifting one handle only will split the packing pieces. Remove the packing pieces and the rounds and then replace the packing pieces in the box.

To Close.

802a. Place the rounds in the cradle. Fit the packing pieces in place, making sure that the tapes on the clips are well tucked down. Fit the lid of the box and screw down evenly on each wing nut. Key, Box, Ammunition, No. 3, should be used as necessary.

Ammunition Box C.290.

803. This box holds two rounds of Q.F. 4-inch, Mark XVI*, fixed ammunition. It is of steel, and is of similar shape to the C.222, which it supersedes.

The lid is at the end and is secured by four bolts; these are tightened or released by a "high speed," or brace type spanner.

Container, Ammunition, Q.F., 4.5-inch Gun. C.217. Plate 35.

804. This container holds one round of 4.5-inch fixed ammunition. It is of rolled paper and its lid is secured by a webbing harness and quick release buckle; sealing eyelets are provided in the buckle and securing straps. The container is sealed by a wire threaded through the eyelets and secured by a lead disc.

Containers, Cartridge, Q.F., 5.25-inch Gun, C.227. Plate 35.

4.7-inch Mark XI Gun, C.228.

4.5-inch Gun, C.279.

805. These containers each hold one cartridge of Q.F. separate ammunition. They are of rolled paper and are similar in design to the container C.217.

CH. XXII—SECTION 4.—LABELS.

806. All packages containing Government explosives have a Station label or lead seal and a combined Group and Government Explosive label. Usually they have also a Contents label affixed to them.

Station Label. Diagram 5.

807. This white linen label has two parallel black stripes with the Station monogram between them. Two of these labels are placed on each package by the packing or repacking station to indicate where the package was sealed. The labels are affixed to cover the joint between the lid and the body, over a hasp or the knot of the sealing tapes; so long as both labels are intact the contents may be accepted as correct.

Group and Government Explosive Label. Diagrams 1, 2 and 3.

808. The size of packages used for the public conveyance of explosives is limited by the Board of Trade, but the limitations do not apply to packages containing Government Ammunition Stores. These packages have Group and Government Explosive labels to indicate that they contain Government explosives of the Group number specified in N.M. & E.R's. The Group number is in the centre of the label.

Sometimes Group Stowage ashore and afloat are not identical, and in this event a Composite label is affixed. (*Diagram 1*). The explosive is classified for general purposes under the Group number which forms the numerator and for the special purpose of stowage in H.M. Ships under the Group number which forms the denominator.

Contents Label. Diagram 4.

809. A Contents Label is affixed to Q.F. Cartridge and Ammunition boxes and to most packages containing stores filled with explosive giving full particulars of the contents. It is put in the most convenient place for reading, stowage ashore and afloat being taken into consideration.

CHAPTER XXIII

AMMUNITION EMBARKATION AND SUPPLY

EMBARKATION OF AMMUNITION.

815. Ammunition is as a rule embarked from lighters but in certain conditions embarkation may be carried out with the ship alongside a jetty.

Embarkation involves :—

- (1) Lifting the ammunition on board and
- (2) Striking it down to magazines and shell rooms.

Hoisting inboard is usually by an ammunition derrick or a general service derrick. Aircraft cranes are also used for hoisting in the smaller packages. In small ships, shell may be embarked through side scuttles and packages embarked through wooden chutes.

Hoisting Inboard.

816. Arrangements for hoisting inboard include :—

- (i) Screw-grabs for shell above 6-inch calibre.
- (ii) Scale-boards for shell of 6-inch calibre and under and for Q.F. ammunition in containers. Scale boards are wooden trays slung from the four corners by wire ropes led to a central ring. Various sizes are used according to the maximum load which can be lifted by the derrick or crane.
- (iii) Special slings of various kinds for cordite cases and for the larger boxes.
- (iv) Steel cargo nets for the smaller packages.
- (v) Webbing straps or two-legged slings for pom-pom and similar boxes.

After the ammunition has been placed on deck it is struck down a line of hatches to the magazines or shell rooms. An additional operation may be necessary, for example, boxed Q.F. ammunition to be stowed in bottle racks must first be unboxed.

Main armament ammunition for capital ships requires special arrangements for striking down. Shell or cordite cases are lowered inboard and placed on a transporting trolley or on a "perambulator" which is wheeled along the deck to the embarking hatch. The perambulator is placed over the open hatch and the shell or the cordite case lifted by a fixed davit; the perambulator is removed and the shell or the cordite case is struck down.

817. Arrangements for striking down include :—

- (i) Screw grabs for horizontal handling of 15-inch shell in older battleships.
- (ii) Six-legged slings for 15-inch cordite cases in older battleships.
- (iii) Combined slings and screw grabs for main armament shell and cordite in *Nelson*, *Rodney* and later battleships.
- (iv) Mechanical endless chain or wire hoists in reverse and operated by hand.
- (v) Various types of slings, bags or strops for other ammunition rounds or boxes.
- (vi) Carriers, hand, for 4.7-inch shell.
- (vii) "Cruets" or carriers, ammunition, quadruple, and quadruple shell bars. (See para. 828).
- (viii) Carriers, ammunition, single or double. (See para. 826.)

818. Typical ammunition arrangements, e.g., for a modern cruiser of the *Fiji* Class, are as follows :—

Six-inch shell are hoisted inboard by ammunition derricks and struck down in bags by whip and power bollard through a run of hatches direct to shell room. Cordite cases are hoisted inboard and struck down in slings in a similar manner.

Fixed ammunition for the 4-inch guns is hoisted in by the aircraft crane and struck down by means of the endless chain hoists (made reversible for this purpose) or in cruets through hatches by whip and power bollard.

Boxes of pom-pom and small arms ammunition are hoisted in with the ammunition derrick and struck down by power or hand-operated whips through hatches and scuttles to the magazines.

AMMUNITION SUPPLY.

819. The supply route from magazine or shell room to the gun is usually broken and transport is in one or more stages in a horizontal or vertical direction.

Means of horizontal transport include :—

- Trolleys or barrows.
- Overhead rails fitted with travelling grabs which may be moved by hand or by power.
- Conveyors, hand or power operated.
- Hand-through scuttles.

Means of vertical transport include :—

Hand-ups and Vaughan chutes, *i.e.*, steeply inclined chutes passing through the decks up which the ammunition is pushed by hand. For 4.5 inch fixed ammunition power operated hand-ups are used.

Whips. Ammunition may be hoisted through one or more decks either by hand or by means of an electric bollard.

Hoists forming part of the gun mounting.

Endless wire hoists.

Endless chain hoists.

Endless whips.

820. In capital ships overhead rails are fitted in the shell rooms for conveying main armament shell from the bins to the hoist in hydraulically-operated grabs. Special facilities are also provided for conveying cordite charges to the scuttle. In *King George V* and *Nelson* classes inclined chutes with shaped wooden rollers are fitted, and in *Queen Elisabeth* and *Royal Sovereign* classes special trolleys carry four charges.

821. Ammunition for Q.F. guns 4-inch, and 4.5-inch, and for 4.7-inch guns other than those in turrets is supplied direct from the magazine to the deck below the gun or to a compartment on the gun deck. The rounds are transferred from the top of the hoist by way of "hand-ups" and "shell chutes" to the gun deck and into the ready-use lockers.

822. In small ships where ammunition has only a short journey to the gun deck, an endless whip is fitted which extends from the deck of the magazine to the deck head at the top of the hoist. The whip has two hooks arranged so that one travels up when the other is on its way down; two rounds at a time can be hoisted using either bags or single carriers.

823. Difficulty in arranging a rapid supply of ammunition to close-range armament may arise through :—

- (i) Inconvenient location of the magazines in relation to the guns. In allocating space such items as main machinery and main and secondary armament ammunition take precedence.
- (ii) The necessity for stowing more than one type of ammunition in the same magazine.
- (iii) Ammunition being packed in boxes. Boxes must be hoisted singly by whip (usually worked by an electric bollard).

To overcome this delay a proportion of ammunition is stowed unboxed in Ready-Use Lockers and in boxes in Ready-Use Magazines and/or Magazine Lockers. (*Paras. 867 and 868.*)

824. Alternative supply arrangements vary according to the ship and to the restrictions imposed by considerations of weight and means of operation. In large ships, where the primary method of supply is by power, the secondary supply arrangements are through a line of hatches using a single whip with bags or carriers hoisted by a bollard hoist (where possible) or by hand. In small ships the secondary supply arrangements are often the main route of supply for pom-pom and other ammunition for close range weapons.

AMMUNITION SUPPLY APPLIANCES.

825. Various appliances and devices are used for the supply and safe transport of ammunition from magazines and shell rooms to gun positions. A list of the principal devices is set out below with brief remarks on the purpose for which they are used. The appliances used to supply guns mounted in turrets are not included as detailed descriptions of these are given in the various gun mounting handbooks.

CH. XXIII.

APPLIANCE	DESCRIPTION	PURPOSE FOR WHICH USED
Power operated :—		
Dredger hoist ...	Horizontally placed buckets attached to motor-driven endless chains	Hoisting B.L. 6-inch shell and cordite (in Clarkson's cases)
Chain hoists (E.C. hoists) and Endless wire hoists	Ammunition hoisted vertically by "heads" attached to motor-driven endless chains	Hoisting Q.F. fixed ammunition, Q.F. cartridges (separate), Q.F. 4.7-inch shell
Motor bollard hoist (double or single drum)	Single whip with— (i) Shell or cartridge bags (ii) Carriers, ammunition, single, double and quadruple (iii) Carriers, shell, hand, and carriers, shell, quadruple (iv) Slings (for boxed ammunition)	Various, including the following :— B.L. and Q.F. shell and cartridges Q.F. fixed ammunition Q.F. 2-pdr. and S.A. ammunition in boxes
Mechanical hand-up	Chute with motor-driven sprocket wheel and belt. Angle of chute 45° approx.	Supplying Q.F. 4.5-inch fixed ammunition
Mechanical conveyor	Horizontal chute with motor-driven belt	For transporting Q.F. 4-inch or 4.5-inch ammunition
Hand operated :—		
Hand-up chutes ...	Chute with cam and handworked wire haul up, fitted between decks. Angle of chute 45° approx.	Supplying Q.F. 4.7-inch shell to gun positions. Not considered practicable for a weight heavier than 62 lbs.
Hand conveyor ...	Chute, generally portable, fitted at a convenient inclination determined by the maximum supply height and minimum delivery height permissible	For supplying 4.5-inch ammunition to gun casemates in positions where a fixed mechanical conveyor would be unsuitable
Ammunition hand-up	Chute fitted between decks. Rounds are pushed up by hand. Angle of chute 45° (approx.)	Supplying Q.F. 4-inch fixed ammunition suitable for deck heights of 7-9 ft.
Vaughan chute ...	Chute and hand worked pulley. Angle of chute 45° (approx.)	Supplying Q.F. fixed ammunition. In some cases the chute has been adapted for use in hoisting Q.F. 2-pdr. ammunition in boxes
Carrier hand-up ...	Whip with a carrier at one end and a balance weight at the other	Hoisting Q.F. 4-inch or 4.5-inch fixed ammunition from a lower to an upper magazine
Endless whip ...	Endless whip with hooks attached, and sheaves at top and bottom of hoist (diameter of sheave, 7 inches)	Suitable for hoisting shell and cartridges in bags or a round of Q.F. fixed ammunition in a carrier, ammunition, single
Hand-up platforms	Built-up or hanging platforms, usually fitted with back rest and body belt for the safety of the operator in a seaway	For positions where owing to restricted space it would not be possible to fit a chute hand-up
Hand-down ...	Sloping chute with spring buffer at the lower end	For supplying ammunition from an upper to a lower magazine or shell-room
Miller's flaps ...	Hinged half plates or gratings (flaps) fitted with return springs. Usually a toggle or lead ball on the whip opens the flaps; when the ammunition which is being hoisted has passed through, the springs close the flaps. Arrangements are made for pinning the flaps in the open position	Fitted in ammunition trunks where there is a possibility of rounds falling down the trunk when unhooking. They are not fitted where Q.F. cartridges or fuzed shell are hoisted unless provision is made to prevent the flaps coming into contact with, and damaging, the ammunition
Hand-through supply scuttles	Shuttered openings in bulkhead through which ammunition is passed and placed on a tray (where fitted) on the receiving side	Fitted where necessary through bulkheads of shelters and deck houses to gun positions in destroyers and sloops. Used also in some magazines where a bulkhead divides the magazines into two separate compartments

Note—(i) Where exposed to the weather, coamings and watertight covers are fitted to the openings in the deck through which chutes are worked. The covers should be so fitted that they can be placed in position, if required, while the chute is rigged.

(ii) In general, the chutes are portable and suitable stowage is to be provided for them when unrigged.

CARRIERS, AMMUNITION AND SHELL.**Carriers, Ammunition.**

826. The designs in general service hold the following quantities of ammunition :—

Single type—One round of fixed ammunition.

Double types—Two rounds of fixed ammunition.

Quadruple types—(i) Four rounds of fixed ammunition.

(ii) Four Q.F. cartridges.

(iii) Two Q.F. cartridges and two projectiles.

The quadruple type is commonly known as an ammunition "cruet." The double and quadruple types have fittings for guide and hoisting wires and arrangements for retaining the ammunition. The cartridges rest on rubber pads.

827. There are three designs of quadruple carrier for fixed ammunition and cartridges :—

(i) *The "all-round" type* : Rounds are loaded into and removed from either side. This design cannot conveniently be used where space is restricted on one or two sides and is therefore being superseded.

(ii) *The "one-way" type* : Rounds are loaded into and unloaded from one side only.

(iii) *The "straight-through" type* : Rounds are loaded into and unloaded from either one or two sides.

The guide wires of (ii) and (iii) may be so arranged that the carrier in transit revolves through an angle up to a maximum of 90° in order that the rounds may be unloaded where required if restriction of space will not permit the orthodox arrangement. The double and quadruple carriers are hoisted by a whip and bollard and the hoist is usually trunked up.

Carriers, Shell.

828. Two designs of carriers have been introduced into the service :—

(1) *Carriers, Shell, Hand, Steel*, for Q.F., 4.7-inch and Q.F., 4.5-inch (separate loading) guns. The carrier consists of a tapered steel ring with a wire handle ; the handle is secured to the ring by a handle clip. The carrier is used in place of a bag or strop for hooking to the hoist whip or to a Carrier, Shell, Quadruple. With the exception of ships fitted with endless chain hoists the carriers are on the shell in stowage, thus avoiding the use of rope grommets.

(2) *Carriers, Shell, Quadruple*, Q.F., 4.7-inch, Marks IX-IX*, XII and XII* guns.

The carrier consists of a cross bar, with an eyebolt for lifting, fitted with guide tubes at each end ; on the under side are four hooks for hoisting projectiles in Carriers, Shell, Hand. The carrier is hoisted on guide wires by a whip and bollard and the hoist is usually trunked up.

Bands, Lifting, B.L., 6-inch Projectiles.

829. These are similar to Carriers, Shell, Hand. They are supplied to ships mounting B.L., 6-inch, Mark XXIII guns (except those fitted with sliding shell stowage) for removing projectiles from the upper tiers of the shell bays.

830-834.

CHAPTER XXIV

MAGAZINES AND SHELL ROOMS

GENERAL REMARKS.

835. Explosives carried in H.M. Ships are classified into Groups according to their general characteristics. A Group is identified by a number and has its own particular conditions of storage, *i.e.*, in Magazine, Shell Room, Weather Deck, etc. Where possible, each Group is to be stowed in a separate compartment, and if this accommodation is not available the Groups must be stowed in accordance with the regulations in N.M. & E.R.

Magazines and Shell Rooms in H.M. Ships are given the maximum immunity against penetration by shell and bombs by siting the compartments below the waterline where practicable and as low as possible in the ship, and by armour protection.

836. In addition, arrangements are required :—

- (i) To prevent flash from shell or bombs reaching the Magazine.
- (ii) To prevent the propagation of cordite fires outside the Magazine, *i.e.*, through the train of ammunition from gun to magazine.
- (iii) To provide suitable venting to Magazines and Handling Rooms.
- (iv) To flood the contents of the Magazine.
- (v) To spray the contents of the Magazine.
- (vi) To drench the contents of turret hoists and Handling Rooms.

PROTECTION AGAINST FLASH OR PROPAGATION OF CORDITE FIRES.

837. Protection against flash entering a Magazine is generally made in the form of :—

- (i) Flashtight arrangements in the gunhouse, working chamber and trunk of turret mountings.
- (ii) Regulations limiting (i) the number of charges in the hoists and waiting positions in course of supply, and (ii) the number of cases in the Magazine from which the lids may be removed.
- (iii) Handling Rooms for B.L. ammunition at the bottom of the trunk or hoist separated from the Magazine by flashtight bulkheads. There may be an additional Handling Room at the top of the hoist (*e.g.*, 6-inch hoists in *Royal Sovereign Class*).
- (iv) In Q.F. Magazines with hoists in the magazine the delivery end of the hoist may be either at the deck below the mounting or in a flashtight compartment on the gun deck. Endless Chain (E.C.) hoists for Separate Ammunition are flashtight, but those for Fixed Ammunition are not flashtight.

In some small ships where consideration of weight precludes the fitting of elaborate flashtight arrangements, ammunition may be hoisted by whip and electrical bollard up an open trunk from Magazine or Handling Room to the deck below the gun deck.

838. In power-worked mountings leather aprons protect the Handling Room from flash passing down the gap between the revolving trunk and the fixed structure of the ship. The doors through which ammunition is loaded into the cages of hoists are flashtight and flash can enter only at the moment when the charge is passing into the cage. Access doors, which open outwards from the Magazine, are fitted in bulkheads dividing the Magazine from the Handling Room. These doors would not prevent the entry of flash on the explosion of a charge in the Handling Room and a protective door of thin plating (also opening outwards from the Magazine) is fitted on the outer side of the access door. The protective door is larger than the access door and can be opened clear of the latter. In action the access and protective doors should be kept closed.

839. Charges are passed from Magazine to Handling Room through a flashtight scuttle in the bulkhead. Generally, the arrangement consists of a cylindrical revolving drum fitted in a fixed casing; the drum is recessed to take a charge. The fixed casing is fitted into an opening in the bulkhead, one opening of the casing facing the Magazine and the other opening facing the Handling Room.

When the recess in the drum faces the Magazine the charge (including its container, wrapper or Clarkson's case, if used) may be inserted. The drum of the scuttle is turned by hand until the recess faces the Handling Room into which the charge is withdrawn on to a tray. As the drum revolves, its surface completely closes one opening in the casing before the recessed portion reaches the other opening. The clearance between the drum and the casing is very small, and the passage of flash between Handling Room and Magazine is obstructed in all positions of the drum.

With flashtight scuttles for charges 6-inch and below the axis of the rotating drum is usually vertical; with scuttles for heavier charges it is usually horizontal, the charges rolling out on to a tray in the Handling Room. When the scuttle is not in use the watertightness of the bulkhead is maintained by fitting a W.T. door over the opening on the Handling Room side.

840. In *King George V* Class 14-inch cordite charges are passed from Magazine to Handing Room through a tube fitted at each end with flashtight covers; the covers are so arranged that only one end of the tube can be opened at a time.

Where Clarkson's cases are used in supply from Magazine to gun separate return tubes are fitted down which the empty cases are dropped from the gun decks. Usually the fall of the cases is broken by fitting a canvas sleeve which can be triced up. In some ships the return tubes are led direct into Handing Rooms, care being taken to keep the opening some distance from the Magazine hatch; a scuttle worked by a pedal is fitted on the gun deck and so arranged that it remains closed when not actually in use.

Shell must be protected from a direct hit, but there is little danger of their being ignited by flash.

VENTING ARRANGEMENTS.

841. If a certain quantity of cordite is burned in a closed compartment, *e.g.*, a Magazine, a rapid rise of pressure results, and in consequence the rate of burning is accelerated and the pressure may become so high that sealed cordite cases in the compartment will collapse, their contents become ignited and eventually the whole compartment will be blown up.

Experiments and trials in the venting of Magazines have been carried out. Valuable information has been obtained from a methodical system of reduced scale venting trials which have been verified by full scale trials. The aim of the investigations was to discover a simple method of limiting the pressure reached in Magazines by ascertaining the necessary venting area and venting pressure.

The main factors affecting the problem are :—

- (i) The quantity of cordite burned.
- (ii) The pressure at which the vent operates.
- (iii) The area of the venting aperture.

Other factors of lesser importance are :—

- (i) Whether the vent is into the open air or into another compartment.
- (ii) The volume of unoccupied space in the compartment.
- (iii) The degree of exposure of the cordite.
- (iv) The size of the cordite sticks.

Formula for Adequate Venting Area.

842. The venting pressure has the most direct bearing on the maximum pressure reached. The first requirement for safe venting is a low venting pressure; this in itself may not be enough and a second requirement is a sufficiently large area of vent. A detailed analysis of the trial data indicates that an adequate venting area is given by :

$$A = \frac{1}{8} W^2/a$$

where *A* is the area of vent in square feet and *W* is the weight of cordite in pounds. A venting area of this amount under usual magazine or handing room conditions will prevent the maximum pressure exceeding about 35 to 40 lbs. per square inch, provided the vents operate at about 25 to 30 lbs. per square inch. Magazine structures appear capable of withstanding this pressure momentarily without serious injury, but the vents will necessarily reduce the efficiency of the watertight subdivision.

Conclusions from Trials.

843. The principal lessons learnt from the trials were :—

- (i) The contents of a Magazine should be protected so that fragments or flash cannot penetrate to the Magazine.
- (ii) The amount of cordite exposed bare should be kept to a minimum.
- (iii) A strengthened venting case is required for ships not protected as in (i).
- (iv) Venting arrangements should be provided in Magazines and Handing Rooms of ships not protected as in (i).
- (v) Protected charges give a marked degree of additional safety.
- (vi) Venting plates should preferably be in single units of sufficient size to provide the venting area required. They should be sited so that the pressure cannot be deflected from them by obstacles, etc. Venting should be through the roof of the compartment wherever possible.

Present Arrangements.

844. The present position of magazine venting is that since the introduction of Cordite S.C. (and the increased care in its manufacture, inspection and tests) the risk of spontaneous ignition to a point at which it becomes dangerous is negligible. The arrangements fitted are therefore intended primarily, if not entirely, as precautions and safeguards under action conditions and are designed accordingly. The venting of Magazines into Handing Rooms is considered wrong policy, because with such an arrangement the exposed cordite in the Handing Rooms will become ignited and the

CH. XXIV.

vents between the Magazine and Handing Room now being open the pressure and flash in the Magazine will be actually increased so that the Magazine is practically certain to explode. Venting from a Magazine must therefore be direct to compartments above and so to the open air.

On this hypothesis the following is the practice in operation :—

Capital Ships.

845. The quantity of exposed cordite in the Main Armament Magazine in action conditions is such that if it becomes ignited the rise of pressure will be more than the existing cordite cases can stand unless the venting area is very large. Even with perfectly free venting it is not certain that the whole Magazine will not be blown up. The provision of large venting areas is directly opposed to the principle of providing the Magazine with the maximum protection against shell bombs, splinters and flash, and it is therefore the accepted policy not to vent the Magazines but to position them and provide them with the maximum armour protection.

Handing Rooms are in a different category because there is only a limited amount of cordite in them at any time, and venting can be arranged without prejudice to armour protection. Vent plates are fitted in the roofs of Handing Rooms and over to give venting up through the barbette.

Cruisers.

846. The quantity of exposed cordite in 6-inch and 8-inch Magazines is considerably less than in a battleship's Main Armament Magazine and the cordite cases are relatively stronger. It has therefore been found possible to arrange for efficient venting direct to the open air. If the Magazine Hatches and those hatches immediately over are secured by only two clips (*i.e.*, one on each of the sides next to the hinge) the hatch will vent before the pressure becomes explosive and the area is sufficient to prevent a dangerous rise of pressure, even if all the exposed cordite became ignited. Hatches thus secured are also sufficiently tight against flash from above. Similarly, the manholes over Handing Rooms should have only the clip opposite the hinge engaged.

Destroyers, etc.

847. In small and lightly constructed vessels of the destroyer type the Magazine structure will usually disrupt and vent before a dangerous pressure is reached. In the action state the hatches to magazines are in some cases necessarily open; at other times watertightness is considered of major importance. Furthermore, the Magazines are sometimes stowed with Fixed Q.F. Ammunition, shown by trial and war experience to be relatively safe. Thus, in these ships no venting arrangements are provided and when not open for access, passage of ammunition, etc., hatches should be fully secured.

Summary.

848. Instructions and requirements for the venting of Magazines are now summarised in *Handbook of Damage Control*: these instructions apply to all Magazines 8-inch and below, including Magazines 6-inch and below in *Royal Sovereign* Class. They do not apply to other Capital Ships. The instructions are that certain doors and hatches may be required to act as vents to Magazines. Doors in this category should be partially clipped. Hatches below the deck immediately above the deep waterline should be partially clipped and those higher up should be closed but not clipped. The hatches in question should be those in the most direct line above Magazines. In partial clipping the two clips nearest the hinged side (but not on the hinged side) should be used.

In certain modern cruisers the Main Armament Magazines communicate direct with the turret structures. As there is a sufficient vent up the turret structures it is unnecessary to leave the Magazine hatches in the venting condition and they should therefore be fully clipped and secured.

Modified locking arrangements have been introduced consisting of a lock to secure one of the two clips which are "on" in the venting state; this does not retard venting of the hatch itself.

TO OBTAIN THE MAXIMUM BENEFIT FROM THE VARIOUS SAFETY DEVICES NOW FITTED IN THE MAGAZINES AND HANDING ROOMS OF H.M. SHIPS, IT IS ESSENTIAL THAT THE QUANTITY OF CORDITE EXPOSED BE KEPT TO THE ABSOLUTE MINIMUM.

FLOODING ARRANGEMENTS.

849. Arrangements are fitted to Magazines and Shell Rooms so that each can be flooded from the sea. The system is regulated by a seacock and a flooding valve, both of which must be opened to admit water to the compartment.

One or more flooding valves are fitted to each Magazine and Shell Room. Where the seacock is used solely for flooding a group of Magazines and Shell Rooms, one flood-valve only is required for each compartment in the group, and is fitted to the flooding branch close to the compartment. If the handwheel working the seacock and the handwheel working the flooding valve can be operated from the same position both are kept closed until required. Alternatively, if the handwheels are some distance apart the seacock is opened before the ship goes into action. Where the seacock is used for other purposes additional valves are fitted to isolate each group of flooding branches from the seacock.

Recent policy for new construction omits direct flooding to Small Arms, Pyrotechnic, Pom Pom, Sub-Calibre and smaller magazines; reliance is placed solely on the spraying arrangements referred to in *para.* 853.

Gearing for Operation of Flooding System.

850. Seacocks and flooding valves are worked by rod gearing from various operating positions. Former policy in construction provided these positions :—

- (i) In the Handing Room or where there was no Handing Room the outside entrance of the Magazine.
- (ii) In the flooding cabinet or flooding locker in a position easy of access and, if possible, with protection.
- (iii) An intermediate position.

Typical arrangements are shown in *Plate 37 (King George V Class)* and *Plate 36 (H.M.S. Newcastle)*.

851. The present policy is to fit rod gearing under protection whenever possible and the various operating positions are :—

- (i) In the Handing Room.
- (ii) Above the Magazine and under protection.
- (iii) In a position separated from the Magazine in a fore and aft direction and in a different W.T. division of the ship.

Typical arrangements are shown in *Plate 36 (Fiji Class)*. It will be seen from the plate that, contrary to normal practice, the Shell Rooms are flooded from the fire main; this is because they are situated above the waterline and therefore cannot be flooded from the sea.

Under normal conditions the handwheels at the upper positions are pinned and the coupling in the lower position kept connected and locked to the shaft. In action the upper position is to be unpinned and the lock at the lower position removed; the cotter, however, is not to be withdrawn, but the pin provided is to be inserted in place of the lock to prevent the cotter working out. Flooding can then be effected from either position. The upper rod gearing can be instantly uncoupled if this is found necessary through damage or other causes, but until the necessity arises it should remain in gear.

852. In some older ships instead of the normal handwheel at the upper position a deck plate is fitted at which the gear rod terminates in a squared head for operation by a large T spanner. This arrangement is now obsolescent and is only retained where it would be inconvenient to incorporate the up-to-date arrangements.

The locking arrangements of the system are designed to guard against mistakes. Lengths of shafting can be disconnected elsewhere by removing tapered pins. The flooding valves can then be operated by any form of pipe wrench that would grip the lower part of the rod gear.

An automatic air escape valve is fitted to the crown of each Magazine and Shell Room to allow the air to escape when flooding. A pipe is led from this valve to a position well above the waterline. Where the height of the waterline above the compartment is insufficient to operate the air escape valve a simple exhaust pipe is led to the open.

An adapter is supplied for flooding when in dry dock. It is fitted externally to the seacock and connected to the shore water mains by hoses; the valves for flooding are worked as though the ship was afloat.

Suction Pumps are now fitted generally to Magazines and Shell Rooms. In some older ships only Shell Rooms are so fitted and Magazines, if flooded, must be cleared of water by means of portable pumps.

SPRAYING ARRANGEMENTS.

853. Arrangements are fitted in the Magazines of all Capital Ships and Cruisers for spraying the ammunition stowage with water. Supply is from the fire main service directly over the Magazine and is independent of the Flooding System. Shell Rooms have no spraying arrangements.

A screw-down valve (locked "open") is fitted in each branch pipe near to the fire main. A second valve called a "spraying valve" is fitted in the branch near to or inside the Magazine. Each valve is operated by rod gear and handwheel. A mud box is fitted in the branch on the fire main service side of the spraying valve. Inside the Magazine perforated copper pipes with branches and sprinklers are arranged so that the fronts and tops of all cases can be sprayed. A lead is also arranged to the cordite scuttle for spraying a charge in the scuttle and for this purpose a sprinkler is fitted on each side of the bulkhead separating Magazine and Handing Room.

Sprinklers may be detached for cleaning. A drain hole with a Saveall is fitted at the lowest point of the spray pipe between the spraying valve and the sprinklers for the purpose of detecting leakage in the valve.

To provide a ready supply of water in a Magazine a branch is led off the Spraying Service above the spraying valve. It is controlled by a screw-down valve in the Magazine and is fitted to take a hose. This arrangement also provides a test for the system as far as the spraying valve.

CH. XXIV—SECTION 2.

Gearing for Operation of Spraying System.

854. Spraying valves are operated by rod gearing from any of the following positions:—

- (i) An upper position, usually the flooding cabinet or locker.
- (ii) A position just outside the entrance to the Magazine and close to the valve.
- (iii) In the Magazine.

Present policy is to provide an operating position for each spraying valve separated from the Magazine in a fore and aft direction and in a different W.T. division of the ship.

Typical arrangements for existing ships are shown in *Plate 37* (*King George V Class*) and *Plate 36* (for *H.M.S. Newcastle*). Modified arrangements fitted in more recent ships in accordance with war experience are shown in *Plate 36* (*Fiji Class*).

The valve wheel in the cabinet is locked by a pin; the rod gear can be disconnected only in the Magazine or Handing Room. When the locking pin is in place the valve can be operated only by unlocking and entering the cabinet, Magazine or Handing Room. In action the cabinet is unlocked and the pin removed so that the spraying gear can be operated from any position. The couplings in the Magazine and Handing Room (where fitted) allow the valve to be opened from these positions if damage to the upper position has jammed the gear. This arrangement also allows personnel in the Magazine or Handing Room to disconnect the upper rod gear and close the spraying valve should it have been opened from the outside by mistake or unnecessarily.

The spraying system is partly above armour protection and may therefore be put out of action. In some ships an upper and a lower fire main are fitted, the lower main being below armour. Spraying cannot be carried out direct from the sea because Magazines, as a rule, are not sited far enough below the waterline to allow of a sufficient pressure of water.

When in dry dock a hose is connected from the ship's fire main to a shore main for spraying.

DRENCHING ARRANGEMENTS.

855. A drenching system is fitted to deal with the drenching of exposed charges in the working chamber and Handing Room. Drenching is supplied from the pressure main in 14-inch and 15-inch ships which use water as the pressure medium. Ships with oil as the pressure medium have a special lead off the fire main.

CH. XXIV—SECTION 2.—MAGAZINE STOWAGE

MAGAZINE STOWAGE.

856. The following are the methods of stowing ammunition in Magazines:—

Cylindrical metal magazine cases are stacked in tiers, and arranged so that the strengthening bands of the upper cases rest on the bands of those below. Cases are stowed at an angle of approximately 5° to the deck, being inclined downwards towards the gangway to facilitate the removal of charges. Horizontal movement is prevented by "waved battens" which are secured above each second tier of cases. These battens are metal strips and fit between the strengthening bands of the adjacent tiers of cases. *Plate 38* shows stowage in tiers in 14-inch Magazines of *King George V Class*.

Q.F. stowage may be arranged in nests consisting of cylindrical containers known as "bottle racks" which are built into a specially constructed fixed framework. (*Plate 39*). No battens are required with bottle rack stowage as a special clip is fitted which presses against the base of the cartridge case and retains it in the rack; the clip is easily moved by special tools when extracting the cartridge or round from the container. An improved design of spring-loaded retaining clip is now being fitted.

Where free access to all racks is not possible, "rolling stowage" may be fitted. This form of stowage consists of bottle racks built in a frame mounted on rollers and fitted with a steadying roller at the top; the frames occupy approximately half the gangway space. When the rounds have been removed from the frames and from the fixed bottle racks not blocked by the frames, the empty frames may be moved to give access to the remaining bottle racks.

857. With bulk stowage, *i.e.*, ammunition in cases and boxes, vertical wooden battens are fitted at the front, side and rear to prevent movement. The front and side battens are portable but the rear ones are fixed. The tops of the battens are secured by keep-pins, spring clips or other approved means. *Plate 38*.

With cases and boxes which remain stowed while the ammunition is withdrawn, *e.g.*, Cartridges, B.L. and some Q.F. ammunition, portable battens are fitted at the junction of the cases so that the lids may be readily accessible.

For other stowage the front battens are fitted at the middle of each tier of boxes so that only one tier or row of boxes is freed at a time. When this method is applied to high stowages of small boxes it has the disadvantage that in heavy weather the portable battens may require shoring in place, and when removed may expose a dangerously high tier; in these circumstances an arrangement

of fixed vertical front battens and portable horizontal battens are provided. These vertical battens (made of channel or T-bar) divide the stowage into bays, two boxes in width. The removal of a horizontal batten frees two or four boxes according to the depth of the stowage.

The stowage fitted in any magazine is not to be altered without special authority.

SHELL ROOM STOWAGE.

858. Generally, shell are stowed horizontally in bins.

The driving bands of shell are normally protected by rope grommets. These are removed just before the shell is passed up to the gun. With the exception of ships fitted with Endless Chain hoists, Carriers, Shell, Hand, Steel are used in the place of rope grommets on shell for some marks of Q.F. 4.7-inch guns.

A special form of stowage known as "sliding shell stowage," was fitted in the 5.25-inch and 6-inch Shell Rooms of some recent cruisers and in this shell are stowed vertically in trays in three tiers. The middle tray is unloaded first and when cleared the upper tray is lowered; finally the lower tray is raised to provide easier handling of the shell. Sea experience has exposed certain disadvantages in this type of stowage and it has been abandoned in the latest construction in favour of the normal bin stowage.

CH. XXIV—SECTION 3.—VENTILATING

MAGAZINES.

859. Arrangements are provided for renewing the air in Magazines and the regulations for ventilating are set out in N.M. & E.R.

The usual arrangement is a Supply trunk (fitted with an electric fan) and an Exhaust trunk. Formerly, cooling arrangements were also fitted in Magazines of Capital Ships and Cruisers. Since the introduction of the modern propellant it has become unnecessary to cool charges except those in a "hot" Magazine (*i.e.*, a Magazine adjacent to a hot compartment such as a machinery space).

Bare charges of Cordite S.C. have a tendency to give off toxic fumes which are increased by humidity and heat and may cause rapid exhaustion of personnel under extreme tropical conditions. To protect personnel from these effects modern Capital Ships are fitted with an Air Conditioning Plant to supply air which is partially dried and cooled to the Magazine.

860. The Air Conditioning Plant treats air drawn (1) from the open, or (2) from the Magazine itself, *i.e.*, when the plant is operated on "closed circuit." *Plate 40* shows typical ventilating arrangements.

Static Dehumidifiers

861. Static dehumidifiers, Type "B" (Pattern No. 955) are to be installed as necessary to reduce the humidity in the magazines and thereby assist in maintaining the contents in a dry state. Dehumidifiers should be installed on a scale of one per 600 cubic feet of magazine space.

In order to achieve maximum efficiency from the dehumidifiers, it is desirable that hatches to magazines should be dropped whilst inspections are in progress. Loose water on the deck or in buckets, derived from the periodic tests of spraying or flooding or from any other source, should be removed completely. Dehumidification is best accomplished by preventing ingress of water or moist air and not by frequent reactivation of units.

Each dehumidifier is fitted with a sighting port, the space under which is filled with indicator gel. This gel is normally blue when dry, but turns pink when saturated with moisture. The routine for reactivating saturated dehumidifiers is laid down in N.M.E.R., Article 170, clause (6).

To reactivate, the dehumidifiers are placed in an armature baking oven or the like for two hours at 250° F. Galley ovens must not be used.

(G. 8188/54.—Amendment No. 22.)

CHAPTER XXV

WEATHER DECK MAGAZINES AND LOCKERS

865. These types of stowage may be grouped as follows :—

- (1) Experimental explosives magazines.
- (2) Ready-use magazines.
- (3) Ready-use lockers and racks.
- (4) Miscellaneous explosives lockers.
- (5) Weather deck magazines.

EXPERIMENTAL EXPLOSIVES MAGAZINES.

866. These magazines are fitted exclusively in aircraft carriers for the stowage of various explosive aircraft stores which, until their characteristics have been determined by experience at sea, are not classified as belonging to any particular Explosive Group.

READY-USE MAGAZINES.

867. As a rule, ready-use magazines are compartments fitted for the stowage of ammunition for multi-barrelled guns; they are usually fitted with protective plating. On bulkheads exposed to the direct rays of the sun they are lagged internally with 2-inch thick asbestos. Vent plates are fitted in suitable bulkheads and are provided with a special rubber joint which combines watertightness with ease of venting. Flooding arrangements (and sometimes spraying arrangements) are provided, supply being from the ship's fire main service.

The objects of the ready-use magazine are to provide a rapid and continuous supply to ready-use lockers and to economise in the number of personnel required for ammunition supply.

The compartments stow as much ammunition as is considered adequate for an action, and they should be replenished from the between-deck magazines during a lull.

READY-USE AMMUNITION LOCKERS AND RACKS.

868. Steel lockers and racks are fitted to provide stowage at gun positions (other than turrets or between deck mountings) for a ready-use supply of ammunition. The lockers are flashtight and watertight and are designed to stow unboxed ammunition, *i.e.*, Fixed rounds, Q.F. Cartridges and Cartridges, B.L. in Clarkson's cases. Lockers or racks for ammunition in cases or boxes may still be found, but they are being replaced by those mentioned above.

Ready Use Lockers for close range armament usually stow linked or belted ammunition or magazine drums.

It was formerly the general practice to stow shell in racks at the gun positions with the result that, especially in smaller vessels, shell were exposed to the weather. Fuzes were thus rendered unserviceable and in Arctic conditions shell were frozen in their racks and were useless as a ready use supply. Watertight lockers now replace shell racks for 4.7-inch shell and below, in destroyers and smaller vessels.

The lockers now fitted are usually of $\frac{1}{2}$ -inch plating. Trial and experience have established that these lockers will vent before the contents explode. Light type lockers have no protective value against shell fire or air attack and they are enclosed within the protective screen of the gun wherever practicable.

MISCELLANEOUS EXPLOSIVE LOCKERS.

869. Lockers are provided for explosives which, on account of their Group classification, are not to be stowed below the weather deck or with other explosives. They are usually of light plating and watertight and in certain instances are fitted with flooding arrangements.

Typical examples are :—

- Target Smoke Shell.
- Smoke Floats.
- Smoke Grenades.
- Bombs, Incendiary.
- Bombs, Practice, Smoke.
- Rockets "U."

WEATHER DECK MAGAZINES.

870. Weather Deck Magazines are fitted for the stowage of explosives and pyrotechnic stores which, according to the Regulations, must not be stowed between decks.

CHAPTER XXVI
TARGET AMMUNITION

FALLING TARGET SHELL

875. This is a close range anti-aircraft target.

Externally, the shell resemble normal service base ejection star shell. They are in supply for 12-pdr., 4-inch, Marks V and XVI, 4.5-inch and 5.25-inch guns.

They can be used both as a visual and a Radar target in calibres 4-inch to 5.25-inch. The Tracer should be visible in bright sunshine. The Radar target is provided by the Reflector unit. The 12-pdr. can, however, be used as a visual target only.

4-inch, 4.5-inch and 5.25-inch.

876. These shell are fitted with a time fuze No. 401, below which are a 1-oz. (G.12 gunpowder) burster and a reflector unit. The reflector unit consists of three dipole steel tubes filled, half with tracer composition and half with lead to increase the rate of fall. The tubes are linked in series by a flexible wire to a central column; the column head has a copper disc obturator at its top end to assist ejection.

877. The fuze initiates the burster. The resulting explosion ignites the tracer composition in the reflector unit and blows off the base of the shell. The reflector unit is ejected and the tracer composition burns while it is falling.

The normal burning time is 65 seconds.

12-pdr.

878. This shell has a fuze No. 198, a 2 dr. (G.12 gunpowder) burster, and a long steel star case filled with star composition.

879. The fuze initiates the burster. The resulting explosion ignites the star composition and blows off the base of the shell. The burning star is ejected.

BACK FIRING TARGET SHELL

880. This new type of unrotated shell is intended for practice firings with radar installations and to a limited degree simulates a dive bombing attack; it gives radar indication which can be recorded on the installation.

The shell are in calibres 4-inch, 4.5-inch and 5.25-inch and can be identified by the marking, viz.: black body, a yellow zig-zag band broken with the letters B.F.; and the word "FLARE" stencilled in white.

Special reduced charges *only* must be used with these projectiles. The cartridges can be distinguished by the mouth of the case being closed with a leatherboard cup and the base stencilled B.F., T.G.T.

881. The shell consists of a cylinder fitted with an adapter on to which screws, at one end, a removable-flat ended head, and at the other end, a fabricated tail. The overall length is approximately five feet. On the tail drum, four small loading stops are fitted to take up against the shot seating of the gun chamber.

The shell, whose time fuze No. 390C is fitted in the adapter under the head, has a powder burster, a cordite ejection charge in a celluloid container, and a pressure plate (floating piston). Below this the target flare (which contains the rocket) is contained in split supports, the rocket tail tube being forward of the flare. Fixed to the rocket tail is a wire mesh radar aerial secured to three arms which when free from the split supports are actuated by three springs thereby spreading the wire mesh.

882. (1) Before the projectile is loaded into the gun, the set screw in the head is to be slacked back sufficiently to allow the head to be unscrewed and removed, the fuze is to be set and the head screwed back in place, particular care being taken that the set screw is screwed hard home.

(2) The vent screw, to which a label is attached, must next be removed from the head. The head of this screw is sufficiently proud of the main diameter to preclude final loading, and its removal is also necessary to ensure correct functioning of the fuze by allowing the escape of the gases from the burning of the fuze powder time rings.

(3) The projectile must be handled and loaded carefully into the chamber and pushed home with the appropriate rammer until the stops on the tail engage the shot seating; no undue force should be applied.

The fuze setting and angle of elevation for a particular practice will be determined by the appropriate trajectory charts.

CH. XXVI.

883. The functioning of the fuze magazine ignites the powder burster and cordite ejection charge, and in turn the rocket tail, cordite and target flare are ignited.

The target flare is ejected under action of the pressure plate; the split supports, driven to the rear, shear the threads securing the fabricated tail which falls away, as do the split supports.

The burning target flare speeds towards the firing ship, the radar aerial being extended under action of the springs.

ROCKET GLIDER TARGET

884. The target is a model glider with a wing span of 45 inches, and is used on a shore range. It was originally designed for firing practice with Thompson sub-machine guns.

885. The equipment consists of (1) A Model glider with a rocket motor, and (2) a special launching catapult.

The fuselage, wings, tailplane and fins of the glider are covered by a strong outer skin of special material; its tailplane mounting is hinged so that it can be adjusted for trim. The rocket motor, fitted in the underside of the fuselage, consists of a rocket tube, adapter and striker sub-assembly venturi, percussion cap and a cordite charge.

The catapult performs the following action:—

- (1) The rocket motor is initiated by its firing mechanism.
- (2) Impetus from the elastic cords launches the glider. Once launched, the means of sustained propulsion is provided by the rocket motor.

BRITISH 2-INCH ROCKET, TARGET

886. This rocket provides a moving target whose speed is from 250 to 400 knots. The range is approximately 5,000 yards. The means of launching the rocket are:—

- (1) On board ship.—From a Modified projector, which has a heavy wooden cross as a base.
- (2) On shore.—From an Unmodified projector, which is secured by pressing the feet and spade into the ground.

The Target Handbook should be referred to for general instructions, maintenance and detail.

887. A round consists of the following main parts:—Propelling unit, Target Head and Fins (4). The order of assembly is:—

- (1) Fins to Propelling Unit.
- (2) Target Head to Propelling Unit.

Dismantling is done in the reverse order.

THE PROPELLING UNIT is a shortened 2-inch Rocket U. The tube is 2¼-inches in diameter and 20¼-inches in length.

THE TARGET HEAD is a body tube with a weight and a ballistic cap attached to the forward end and a socket containing the detonator and the igniter at the rear end. Two candles, each with a priming composition are contained in the body. There are four vent holes in the casing for each candle and for protection the holes are covered by lassolastic strips.

888. After launching, the pressure of gas developed by the cordite in the rocket operates a reversible diaphragm and striker, and the detonator is exploded. This ignites priming compositions and in turn the candles are ignited. (A burster ensures the satisfactory ignition of the forward priming composition.) The candles burn simultaneously, the lassolastic strips are burnt off and the gases and flames escape through the vent holes. The flaming rocket travels at a high velocity to the end of its run.

ROCKET TARGET, PRACTICE, 1 lb. See Para. 689.

KEYS FOR FUZES AND PRIMERS

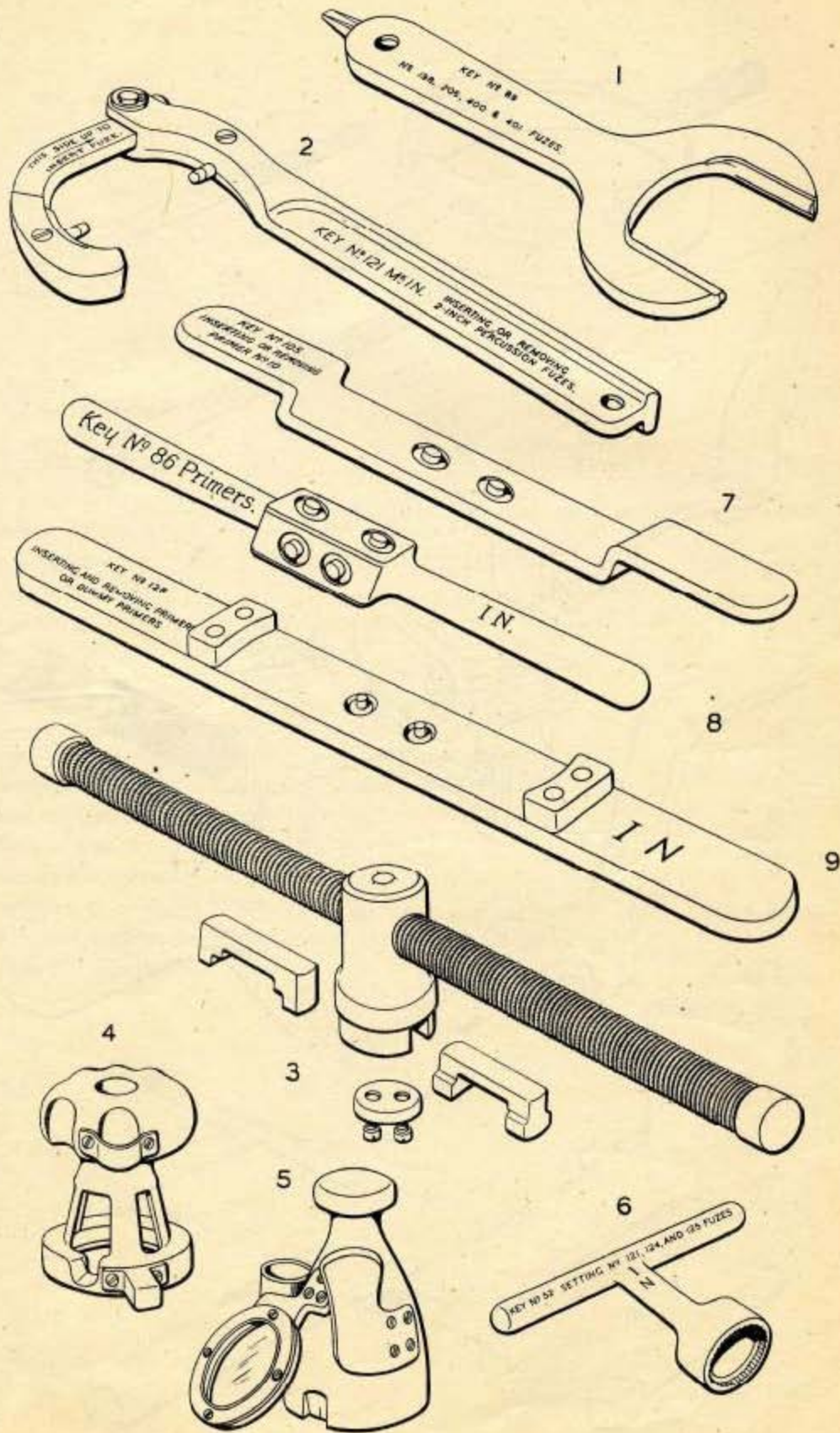

IMPLEMENTS, AMMUNITION A. D KEYS, CASES

10

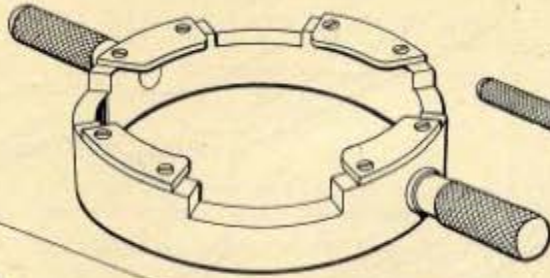

11

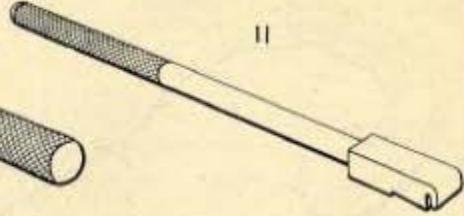

12

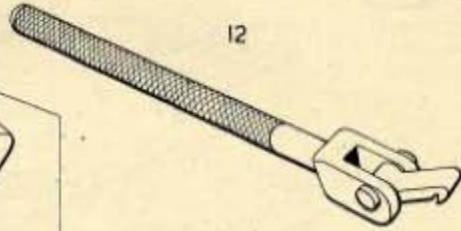

13

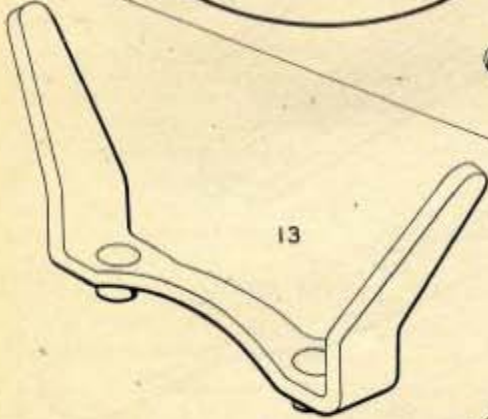

14

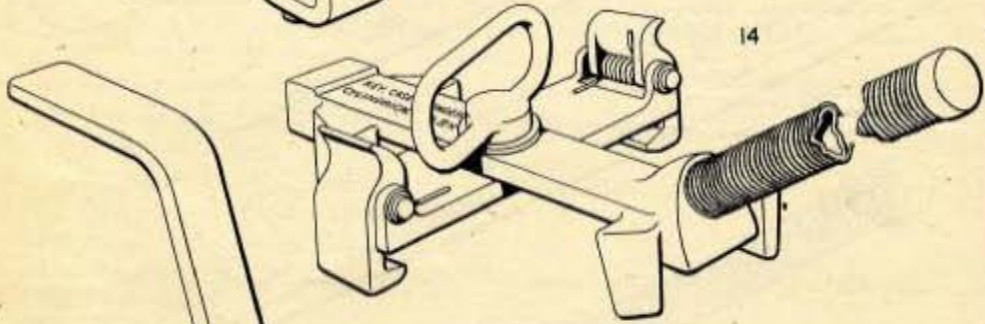

15

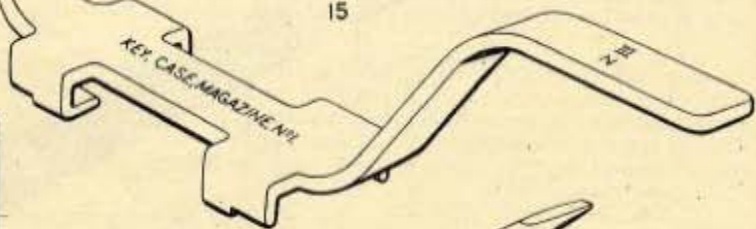

17

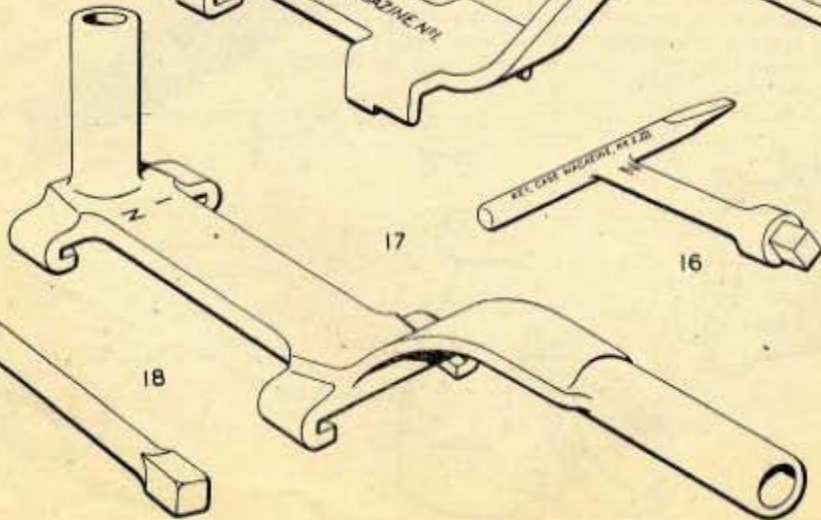

16

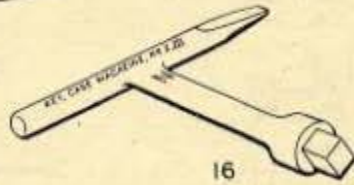

18

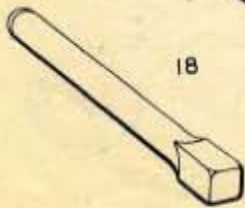

	Para.		Para.
Fuze(s)—Percussion, D.A.— <i>cont.</i>		High Explosive(s)	55
Safety arrangements	347	Chief requirements of Service	56
No. 45P	348	Classification for Service purposes	11
44	353	Initiation of	57
118	358	Initiators	65
230	359	Intermediaries	71
360	364	Shell and bomb fillings	85
241	365	Table of, used in the Service	577
246	370	Hispano, 20 m.m.	654
248	369	Hofman Projector, Mk. III, Cordite Cartridge for... ..	383
251	374	Hotchkiss, Mk. IX Fuze	
253	577		
254	561	I	
255	375	Igniter Covers... ..	123
258	561	Non-removable	126
720	596	Removable	124
259	378	Tear-Off Discs	125
Percussion, Base	379	Igniters for Cartridges, B.L.	122
Delay Fitting and Setting Devices	381	Markings on	122
Safety Arrangements	380	Igniter(s), Shell	329
Hotchkiss, Mk. IX	383	No. 1	330
Nos. 500, 501, 502, 551	387	Igniterless Charges	116
" 159, 346, 480	391	Illuminating compositions	97
TIME, COMBUSTION	397	Incendiary Compositions	100
Clamping	403	Thermite	100
Drill	455	Incendiary Aircraft Bomb	737
Escape holes	410	Lockers for	869
Fuze Powders	399	Inertia Pellets, Description of	341
Safety Arrangements	398	Initiation, Explosive compositions and propellants	11
Setting	408	Sensitive high explosives	11
Tensioning	403	Less Sensitive High Explosives	11
Fuze(s)		Results of poor	11
No. 125	411	Initiators	57
198	417	Cap Compositions	62
400	424	Fulminate of Mercury	58
402	425	Lead Azide	60
TIME, MECHANICAL	429	Intermediaries	65
For Bombardment	433	C.E.	66
Safety Arrangements	431	Picric Powder	68
Setting	429(a)	T.N.T. Crystals	70
No. 206	435		
206, Mk. II	436(iv)	K	
207	440	" K " Device	274
211	441	Keys for Cases	772
215	446	Kit Plasters	482
TIME and Percussion	447		
No. 93, Mk. I	448	L	
Fuzing Shell		Labels	806
Instructions	485	Lead Azide	60
To fuze with No. 211	488	Lead Foil	119
" " " No. 230 over Gaine No. 9 or 10	489	Leather Aprons	838
" " " 14 and 16-inch H.E. with D.A.	492	Lids, Cartridge, Q.F.	159
" " " " " Time Com-	493	Markings on	188
" " " " " bustion... ..	494	Lifting Bands, B.L. 6-inch Projectiles	829
" " " 15-inch H.E. with D.A.	494	" " " for Cartridge bags	121
" " " " " Time Combustion	495	" " " buckets for Cartridges, B.L.	121
(See also Unfuzing Shell)		Lights, Short G.S.	695
Universal Cavity	495a	Line-Carrying rockets	710
G		Line-Throwing guns	713
Gaines	457	Lockers, Miscellaneous Explosive	869
Detonators	467	Lotting of Cordite	20
No. 10	458	Definition of a " Lot "	20
No. 9	462	Luting	747
No. 11	463	Lyddite	72
Gig's Magazine	763	Method of filling shell with	265
G.P. Aircraft bombs	733		
Grenade No. 36M	630	M	
" No. 69, Mk. I	636	Magazines	835
Group and Government Explosives Labels	808	Flooding Arrangements	849
Guncotton	85	" " " in Dry Dock	852
Gunpowder	90	Spraying Arrangements	853
Gunpowder, Sulphurless	94	" " " in Dry Dock... ..	854
H		Stowage	856
Hand Conveyor	825	Ventilating Arrangements	859
Hand-Down	825	Venting	841
Hand Grenades	630	Markings on:—	
Handing Rooms	837	Adapters for Tube Groups	231
Drenching System in	855	B.L. Blank Cartridges	245
Venting of, in Capital Ships	845	Boxes, A.S.A.	798
Venting of, in Cruisers	846	Bombs, Aircraft	740
Hand-operated Ammunition Supply Arrangements	825	Cartridges, B.L.	128
Hand-through Supply Scuttles	825	" S.A. (American) for rifles, etc.	539
Hand-up Chutes	825	" (British)	511
Hand-up Platforms	825	" " 20 m.m. Hispano	578
H.E. Shell (see also Projectiles).	289	" " " Oerlikon	562

	Para.		Para.
Q.F. Cartridges— <i>cont.</i>		Stations Labels	807
Safety Clips	166	Submarine Smoke Candles	685
Separate	151	Sulphurless Gunpowder	94
Special Gunnery School Charges	181	Super Charges	133
Star Shell	171		
Tinfoil in	157		
Quick Match	693		
		T	
R		Table of:—	
R.D.X.	79	Fractional Charges, Reduced Charges, Igniters	139
R.D.X./B.W.X.	266	Fuzes	491
R.D.X./T.N.T.	266(a)	High Explosives	85
Ready Use Lockers and Racks	868	Tail Pistols, Aircraft, Bombs	724
Magazines	867	Tails, Aircraft, Bombs	730
Reduced Charge firings	109	Target Ship Practice Projectiles	305
Reduced Charges for B.L. guns	131	Target Smoke Shell	302
Table of Approved Charges	139	Lockers for	869
Reduced Charges for Q.F. Cartridges	169	Tear Off Discs	125
Instructions to convert 5.25-inch Cartridges	170	Tetryl	68
Removable Igniter Covers	124	Time and Percussion Fuzes (<i>see also</i> Fuzes)	447
Revolver and Pistol Cartridges, S.A.	530	Time Combustion Fuzes (<i>see also</i> Fuzes)	397
Return Tubes for Clarkson's Cases	840	Time Compositions (Fuze Powders)	399
Rifle Grenades	641	Time Mechanical Fuzes (<i>see also</i> Fuzes)	429
Cartridges, S.A., 0.303-inch.		Tinfoil in Cartridges, B.L.	119
Ballistite H, Mk. IZ	528	in Q.F. Cartridges	151
Cordite, Mk. II	529	T.N.T.	74
Rifle M.L.E. Line-Throwing	715	Beeswax	76, 264
Rim-Fire Cartridge, S.A., 0.22-inch, Mk. I	553	Block. Method of filling	263
Rocket Flare, 2-inch	598	Crystals	70
Illuminating, 9 lbs. (Snowflake)	603	Poured. Method of filling	262(a)
1 lb. Magnesium Star	681	Tracer, Cartridges, S.A.	519
" " Red. Green	674	Tracer(s), Shell	322
" " Signal	671	No. 1, Mk. VI	324
" " Target Practice, 1lb.	689	No. 2, Mk. VI	326
" " Glider Target	884	No. 8 and No. 9	328
" " 2-inch Target, British	886	No. 13	325
" " Target parachute	889	No. 16	327
" " "U"	590	Tracers and Igniters, Shell	329
" " "U" 2-inch	592	No. 7	332
" " Lockers for	869	No. 14	333
Rolling Stowage	856	Transport Packages (<i>see</i> Packages, Ammunition)	891
		Tube, Friction	697
S		Tube Group	230
S.A.P. Aircraft Bombe	732	Tube, Cardboard Protecting	141
Cartridge, S.A.	518	Tubes, Vent	205
Shell	285	Drill	219
S.A.P.C. Shell	284	Markings on	221
S.A.P. Tracer Cartridge, S.A.	521	Means of Identification	207
Schermuly Line-Carrying Rocket, 1 lb.	712	4-inch	215
" " 2 lb.	710	5-inch	210
" " 6 lb.	712A	1-inch	218
Instructions for use	711	Packing	222
Shell (<i>see also</i> Projectiles)	250	Stowage	222
Fillings, Method of filling	262		
Shell Fuzes (<i>see also</i> Fuzes)	335	U	
Shell Rooms. Flooding	849	Unfuzing Shell. General Instructions	486
" " Stowage	858	Fuzed with No. 211	487
" " Ventilating	861	" " No. 230 and Gaine No. 9 or 10	490
Shellite	77	14 and 16-inch H.E. fuzed with Time Combustion	492
Method of filling with	265	D.A.	493
Shot	306	15-inch H.E. fuzed with Time Combustion	494
Shrapnel Shell	300	D.A.	495
Silk Cloth for Cartridge bags	120	Universal Cavity	495A
Signal Compositions	98		
Signal Cartridges	675	V	
Slow Match	694	Vaughan Chute	825
Small Arms Ammunition (<i>see also</i> Cartridges, S.A.)	505	Ventilating Magazines	859
Smoke Compositions	99	" " Shell Rooms	864
Calcium Phosphide	99	Venting. Magazines and Handling Rooms	841
Carbon Tetrachloride Compositions	99		
Famyl	99	W	
Hexachloroethane Compositions	99	Wads, Felt	158
White Phosphorus	99	Weather Deck Magazines and Lockers	865
Smoke Float, B.L., 4-inch Mortar, Mks. II and III	657	Experimental Explosive Magazines	866
Lockers for	869	Miscellaneous Explosive Lockers	869
Smoke Grenades. Lockers for	869	Ready-use Lockers and Racks	868
Smoke Shell, B.E.	298	" " Magazines	867
Smoke Shell, B.E., with a Time Fuze	298	Weather deck Magazines	870
Smoke Shell with a D.A. Fuze	299A		
Special Gunnery School Charges for B.L. guns	138	Z	
" " Q.F. Cartridges	181	Zone, Danger	12
" " Q.F. Cartridges	853		
Spraying Arrangements, Magazines	291		
Star Shell (<i>see also</i> Projectiles)	291		
" " 2-pdr.	296		
" " Charge B.L. guns	132		
" " Q.F. Cartridges	171		

CARTRIDGE, B.L. 14 INCH, 84 LB. 9 OZ.
SILK CLOTH, 1/4 CHARGE, FILLED, TYPICAL

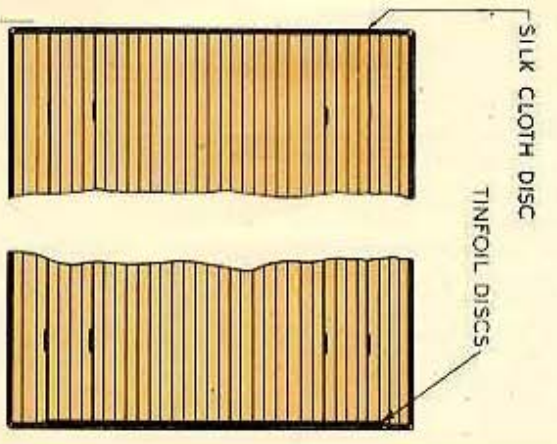
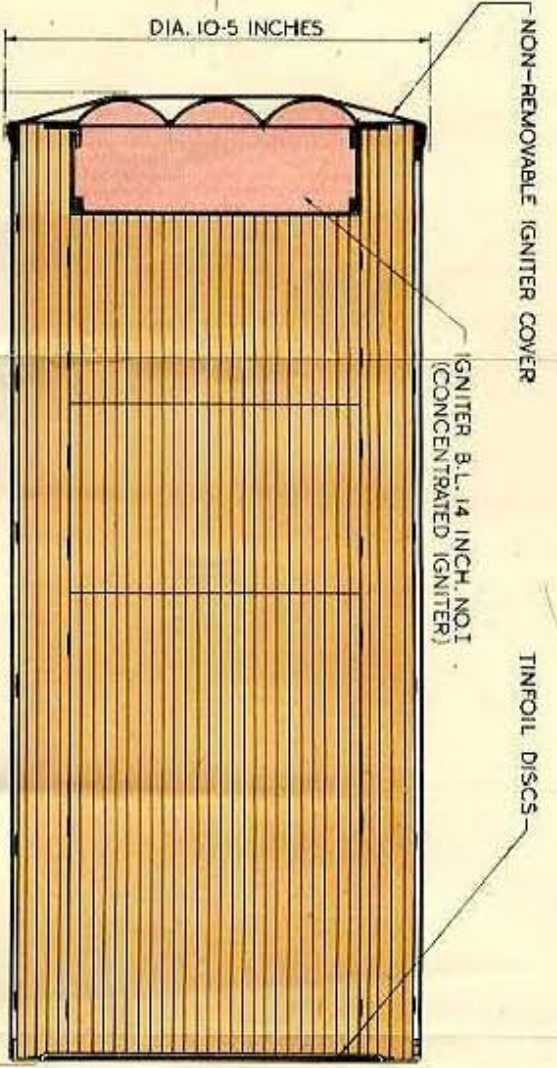
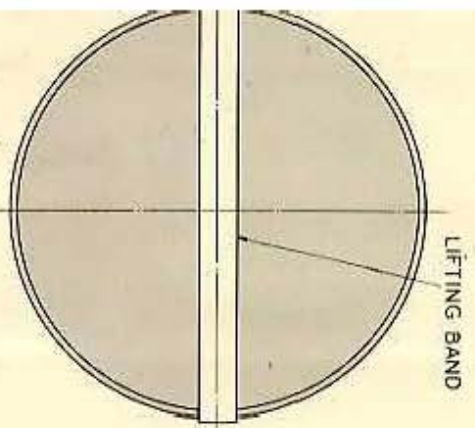

FOR CARTRIDGES WITHOUT IGNITERS

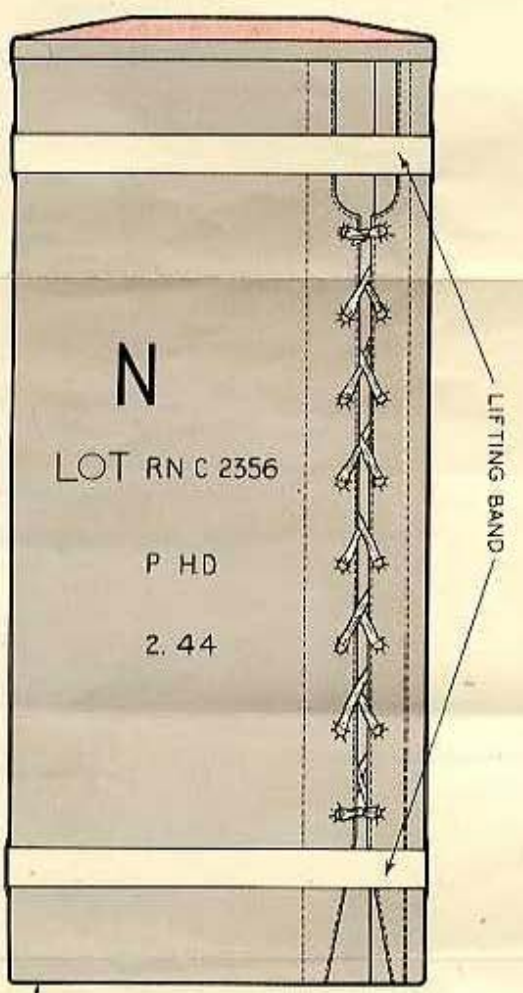
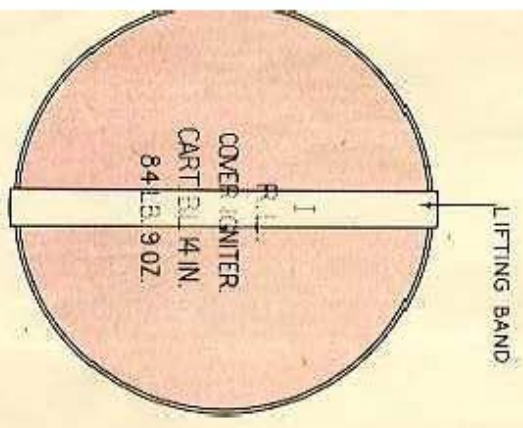

MK I FOIL (IG. N° 1)
R.L.
14 IN.
84 LB. 9 OZ.
S.C. 300
—
1/4

MARKING ON FRONT OF CARTRIDGE
RN C 2356
MARKING ON BASE

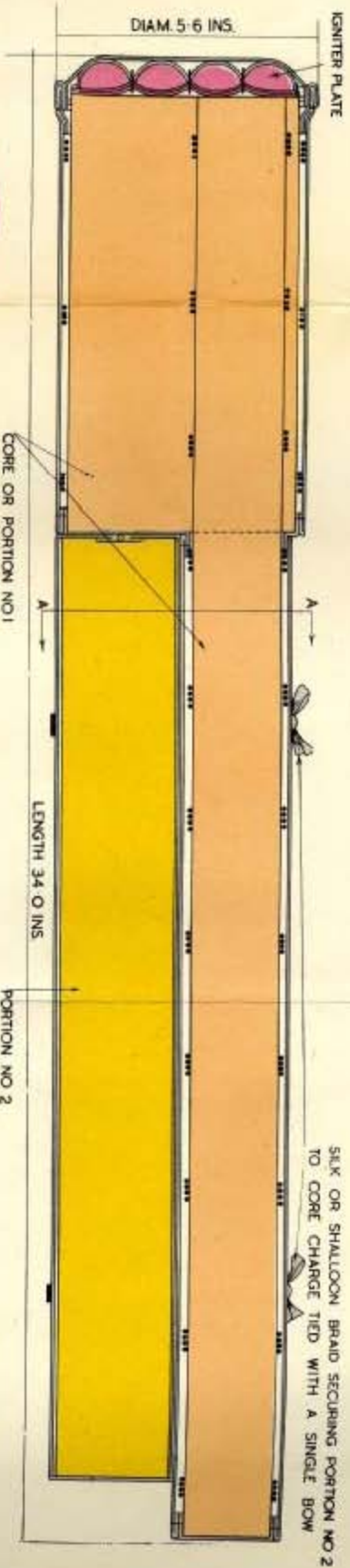

† NUMERALS OR TRACE MARK OF MARKER OF EMPTY BAG

1 + 6 IN. 5 LB. 10 OZ. 3 LB. 6 OZ. SSC. 008.

MARKING ON SIDE OF PORTION NO 1

CARTRIDGE BL. FOR 6 INCH MARK XII GUN 5 LB. 10 OZ. COROTTE SSC. 008 (PLEATED) MARK 1

MARKING ON SIDE OF PORTION NO 2

1 + 6 IN. 5 LB. 10 OZ. 2 LB. 4 OZ. SSC. 008.

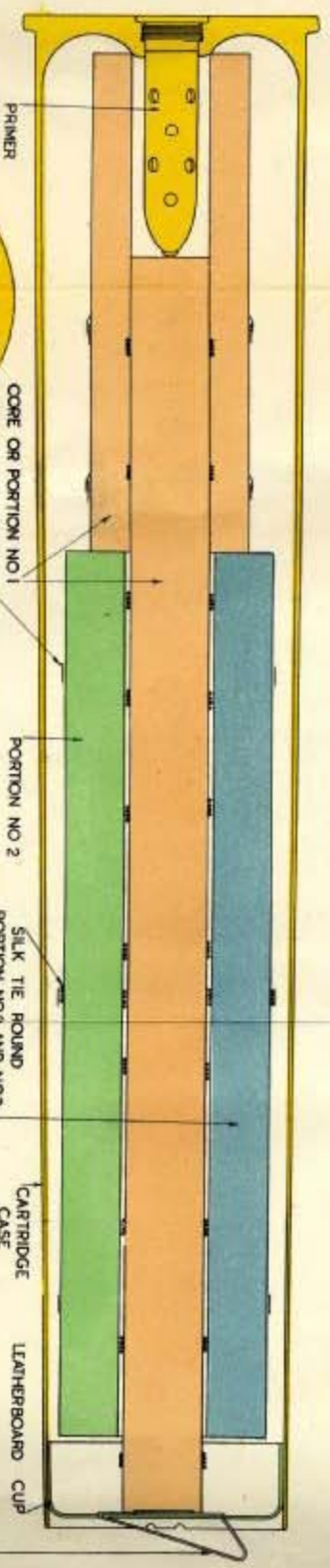
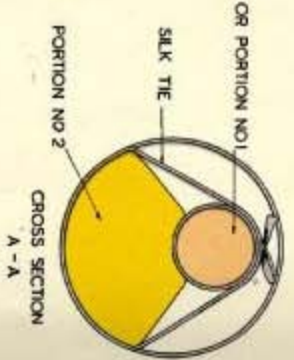

* DISTINGUISHING LETTER OF COROTTE MANUFACTURER
+ LOT NO. OF COROTTE
@ MONOGRAM OF FIRM OR STATION FILLING
@/# DATE OF FILLING

BASE MARKINGS

CARTRIDGE FOR QF 4.7 INCH MARKS IX TO IX DEF AND XII GUNS

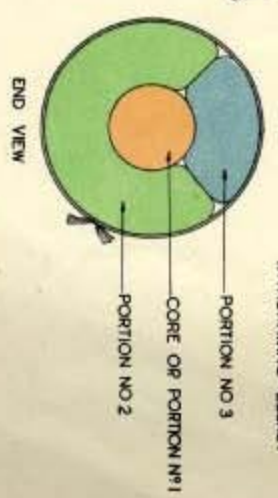

**Q.F. 4-7 IN. SEPARATE AMMUNITION
FILED N.F.O/S**

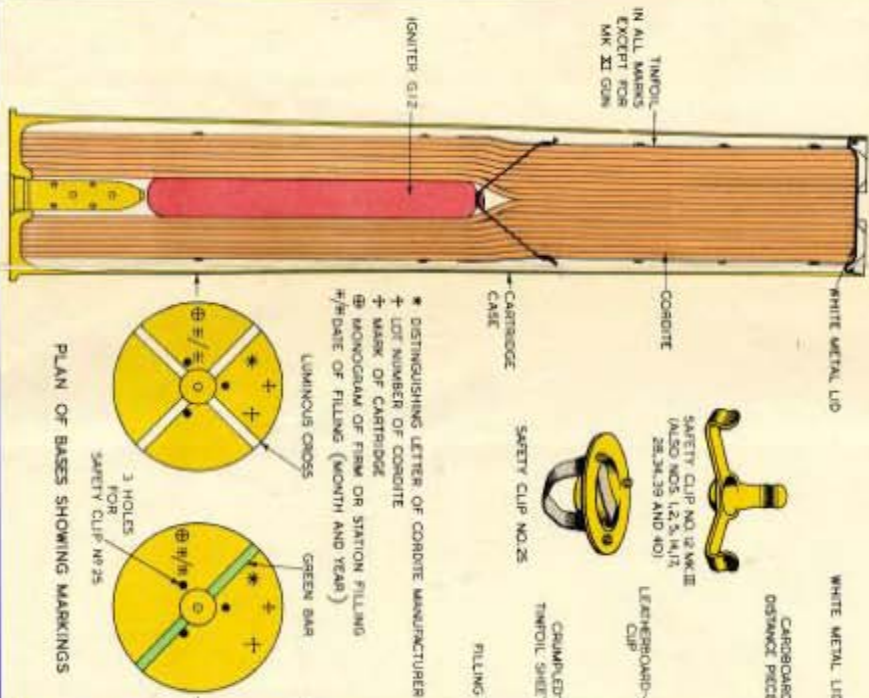

**Q.F. 4-7 IN. SEPARATE AMMUNITION
FILED N. H.**



**Q.F. 4-5 IN. FIXED AMMUNITION
FILED N.F.O/S**

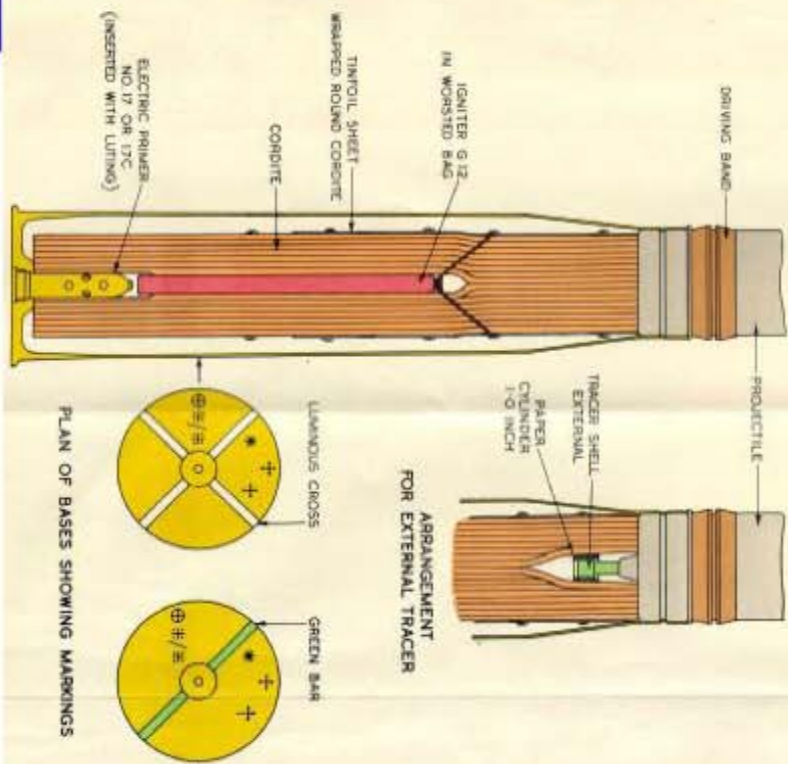

**Q.F. 4-5 IN. FIXED AMMUNITION
FILED N.H.**

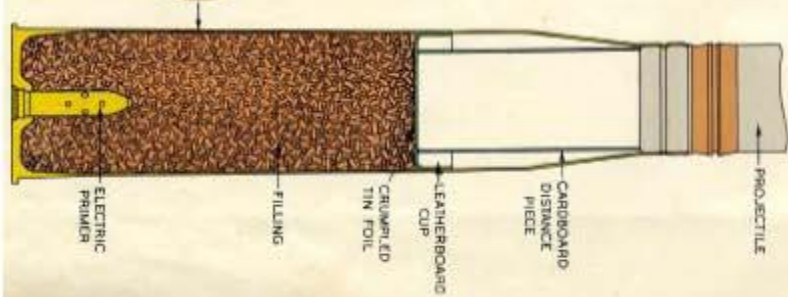

CARTRIDGE, CATAPULT, AIRCRAFT, 8 INCH AND TOOLS REFORMING. CARTRIDGE CASE

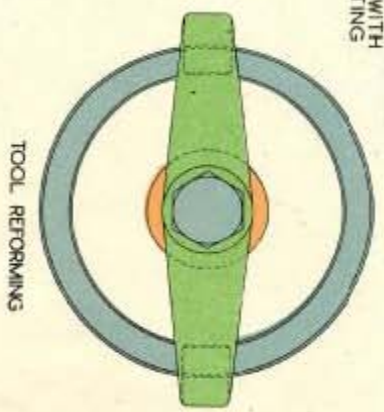
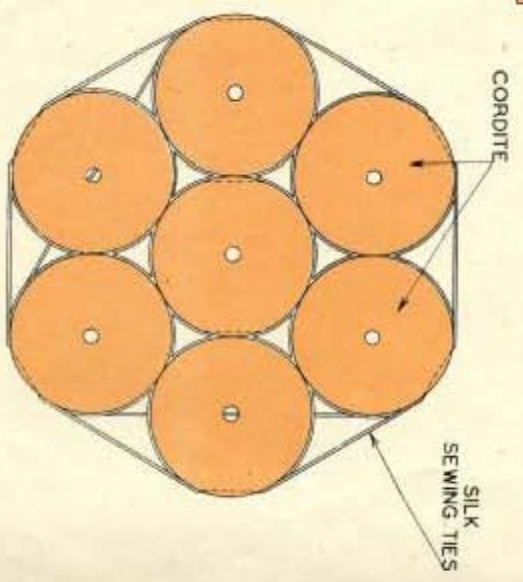
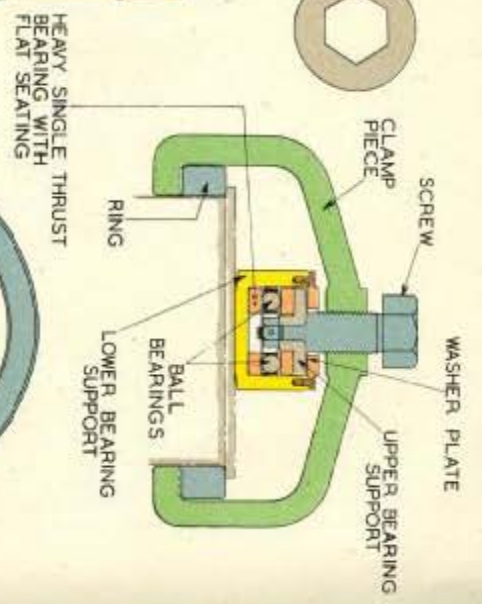
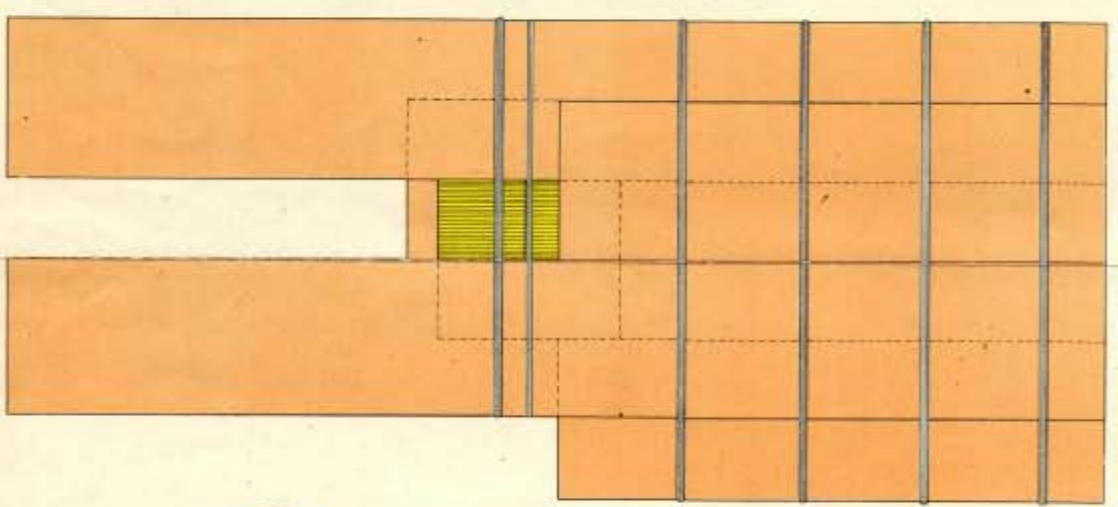
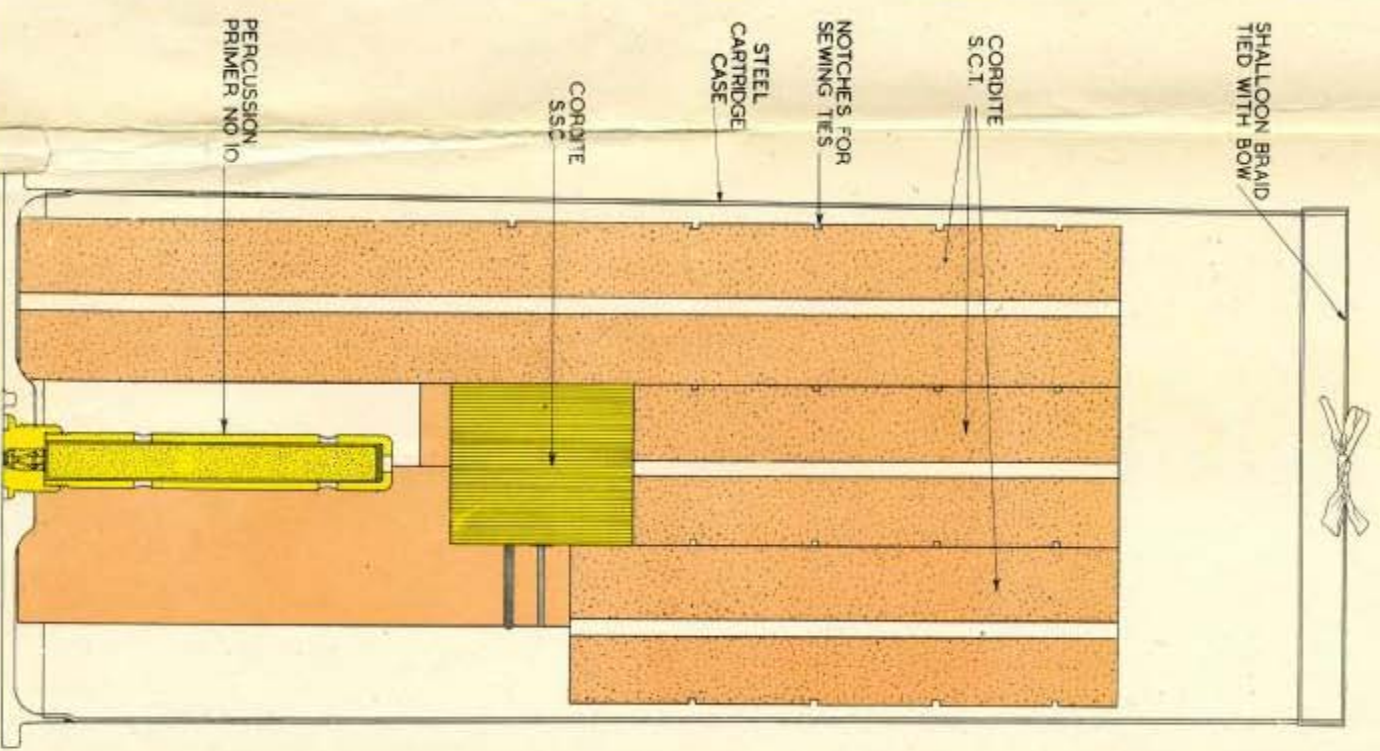

BLANK CARTRIDGES

4-7 IN. Q. F. MARKS IX, IX¹² AND XII*

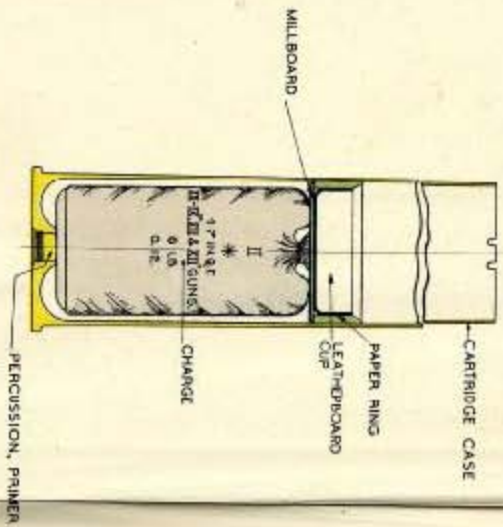

4 IN. Q. F. MARKS V, V¹², XV, XVI AND XVII* GUNS
REDUCED MARK II

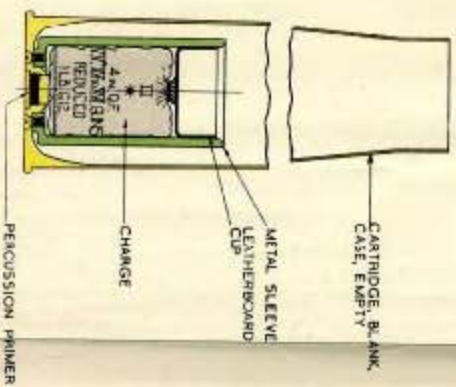

3 PDR Q.F.

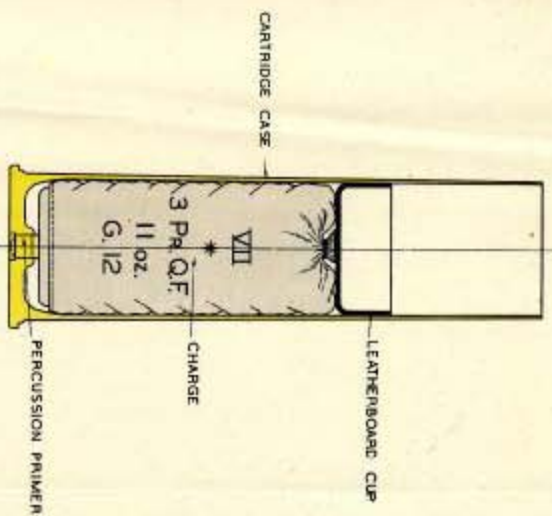

3-7 IN. Q. F. HOWITZER MARK II

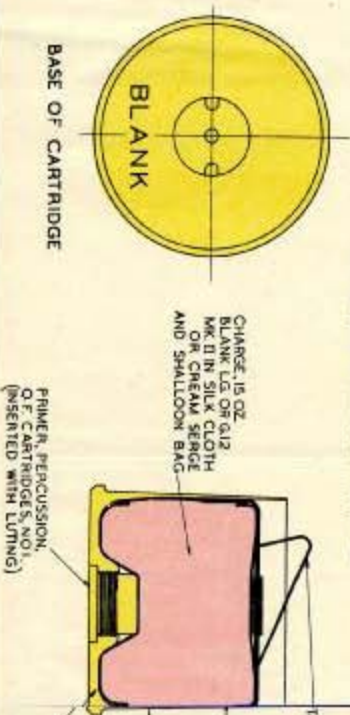

12 PDR 12 CWT

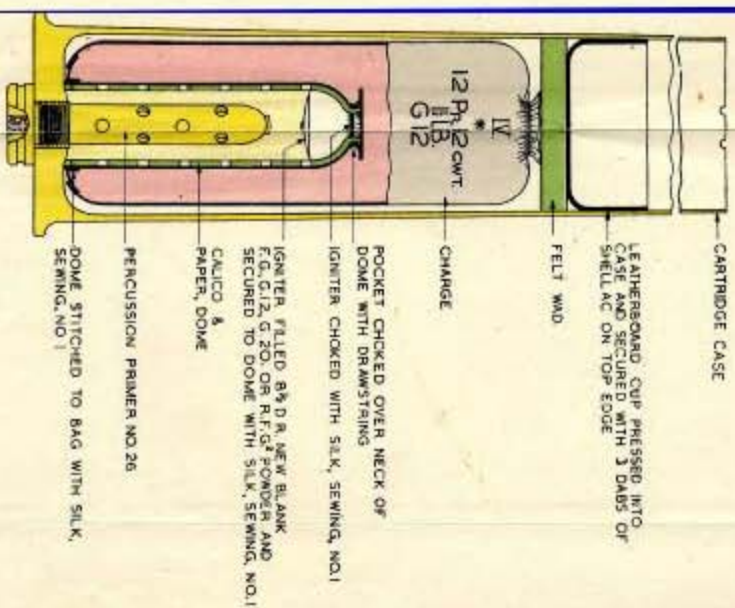

CHARGE TO BE SECURED TO BOTTOM OF CASE WITH SHELLAC IN FOUR PLACES

**SHELL BL. ARMOUR PIERCING. WITH CAP
15 INCH**

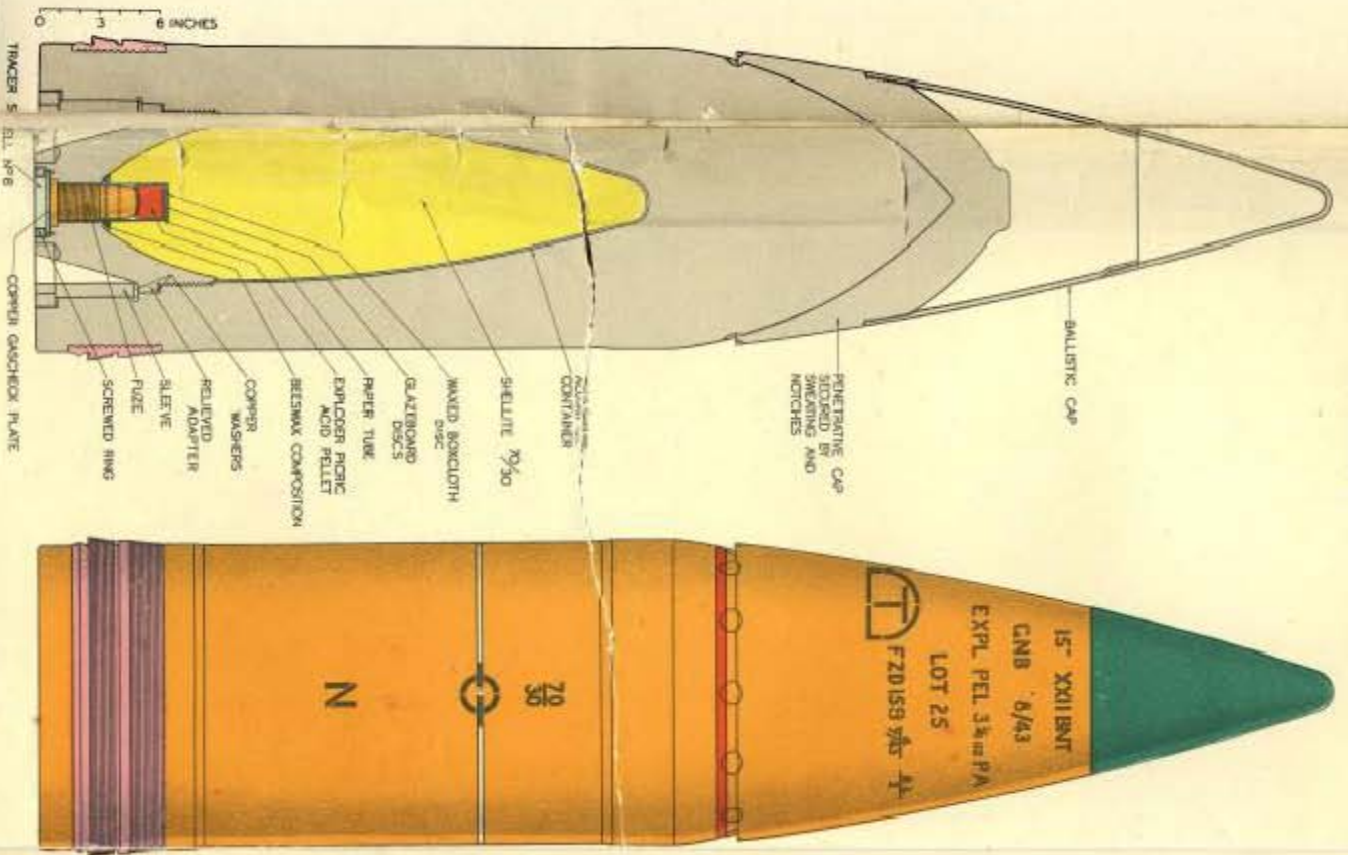

**SHELL BL. SEMI ARMOUR PIERCING. WITH CAP
8 INCH GUN 'K' MARK IB N.T.**

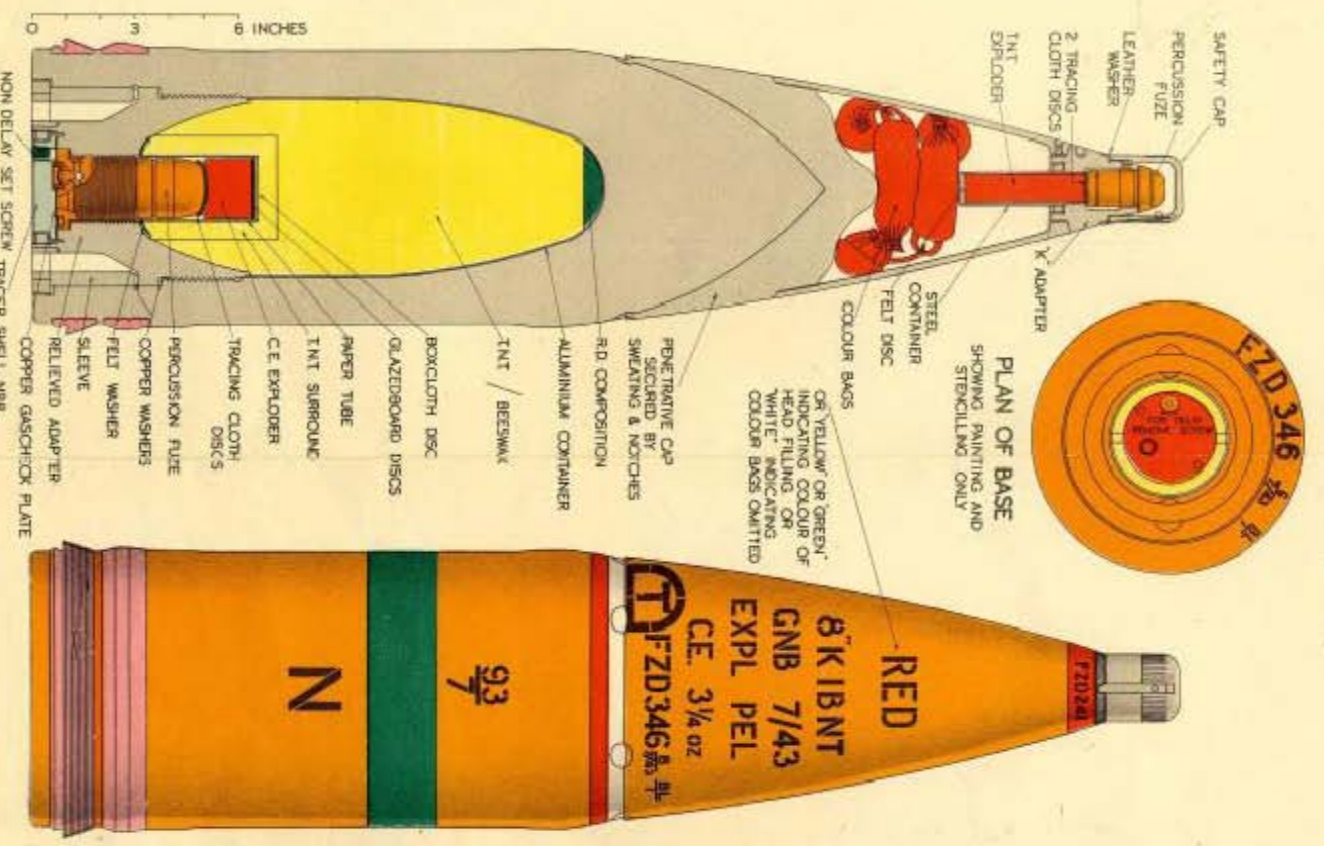

SHELL B. L.
COMMONPOINTED WITH BALLISTIC CAP
6 INCH GUN MARK XXXV B.Q.

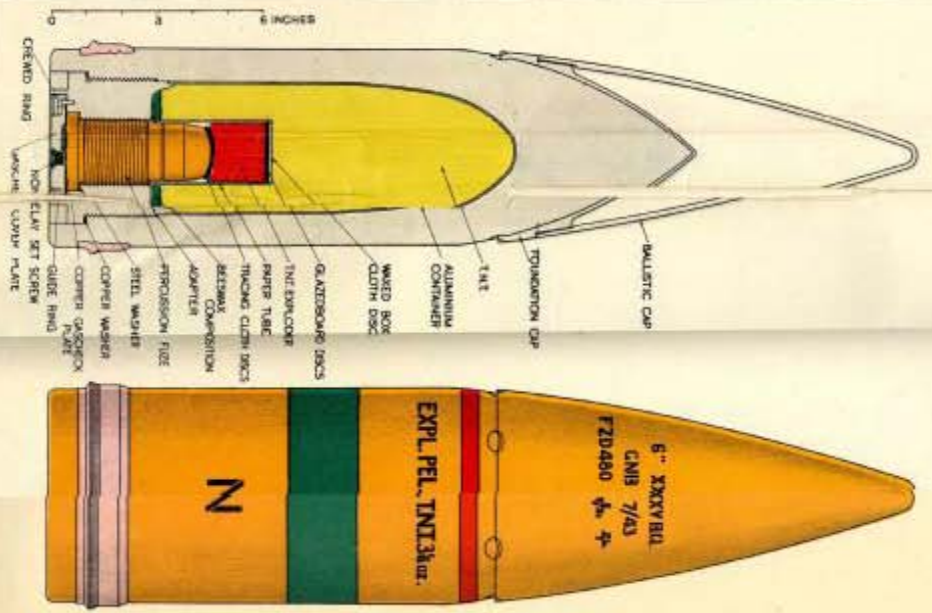

SHELL OF S.A.P. 5.25 INCH A.K. MARK II CI

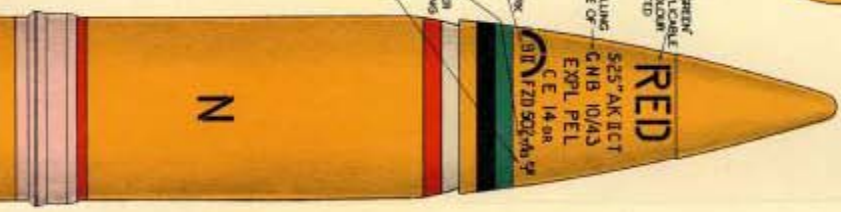
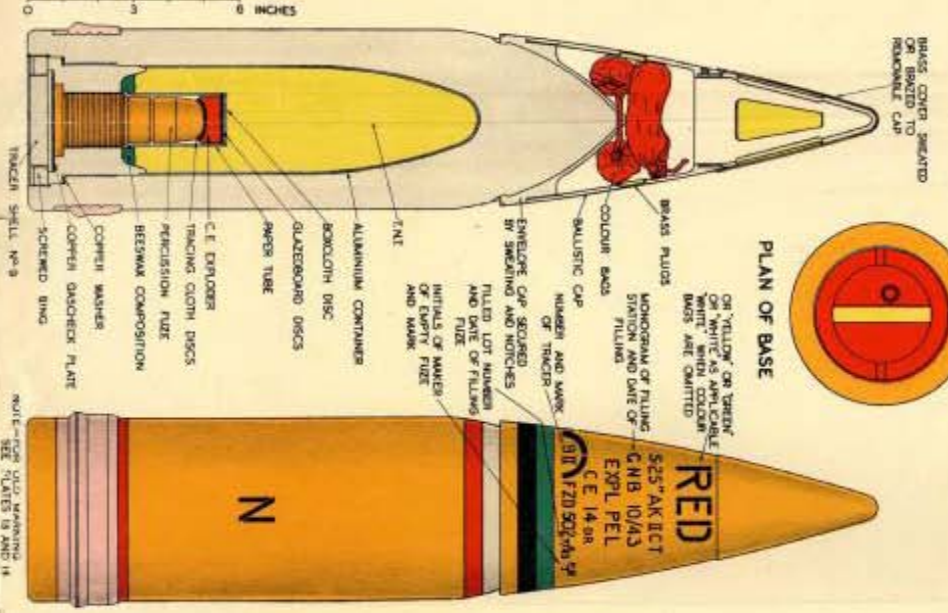

SHELL OF S.A.P. 4.7 INCH, HEAVY
MARK IZA

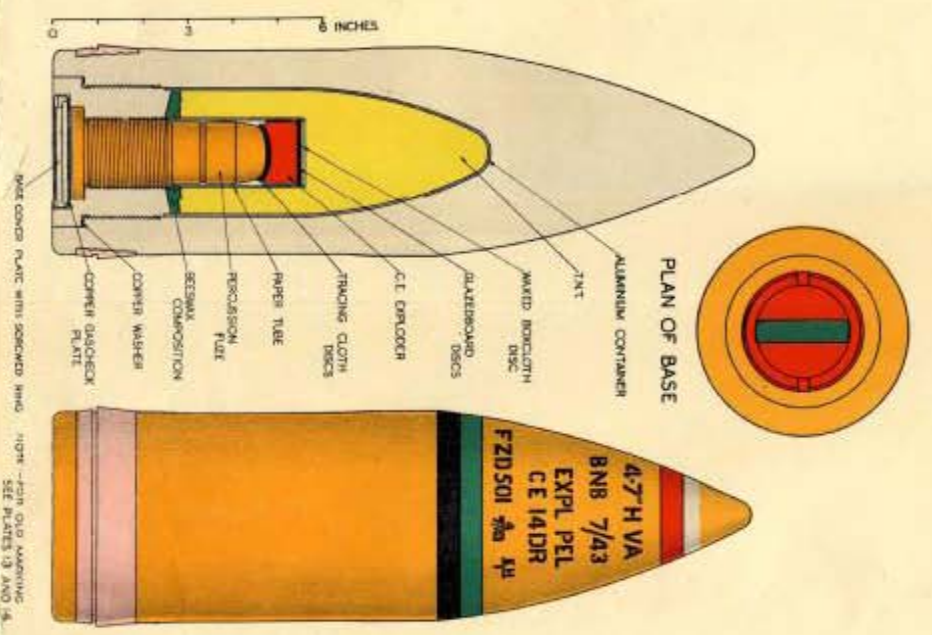

SHELL BL. HIGH EXPLOSIVE, 8 INCH

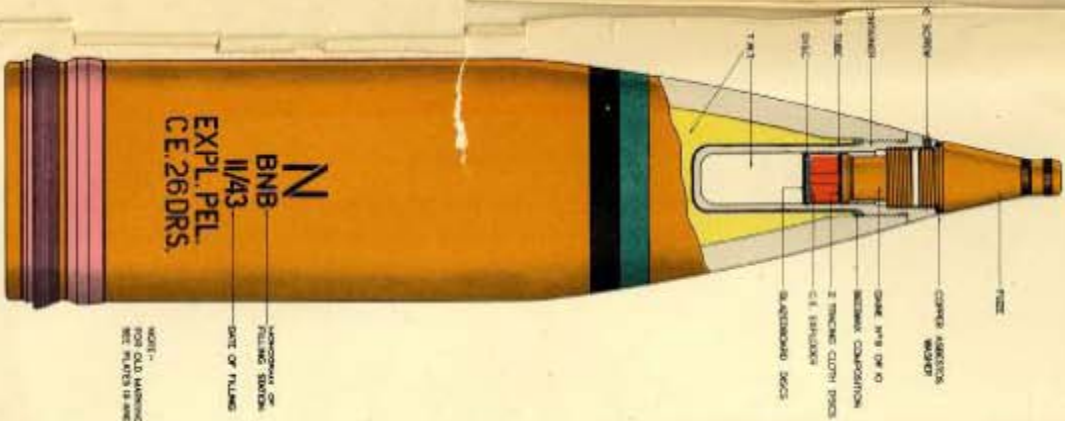

9 INCHES

SHELL, BL. HIGH EXPLOSIVE, 6 INCH GUN, MK. XII A.O. NT.

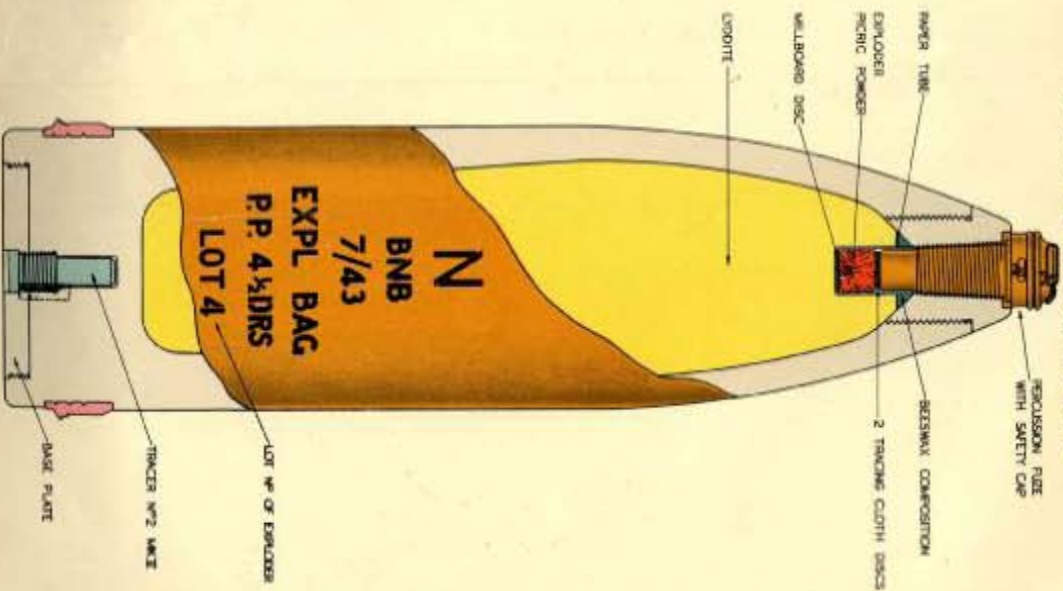

9 INCHES

SHELL BL. OR OE. HIGH EXPLOSIVE, 4.7 INCH HEAVY MARK VII A

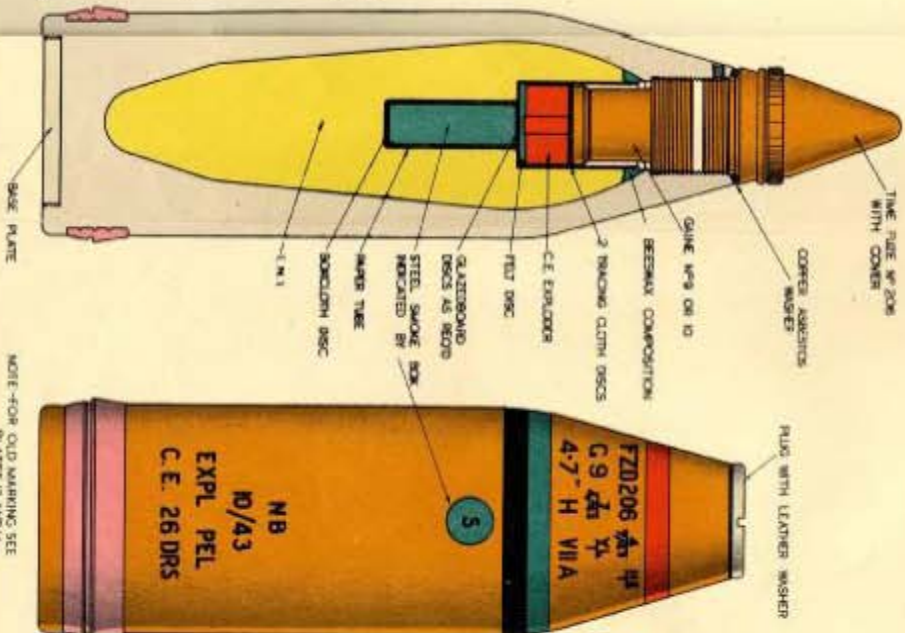

NOTE - FOR OLD MARKING SEE PLATES 13 AND 14

SHELL, O.F. HIGH EXPLOSIVE,
2 PDR. HV

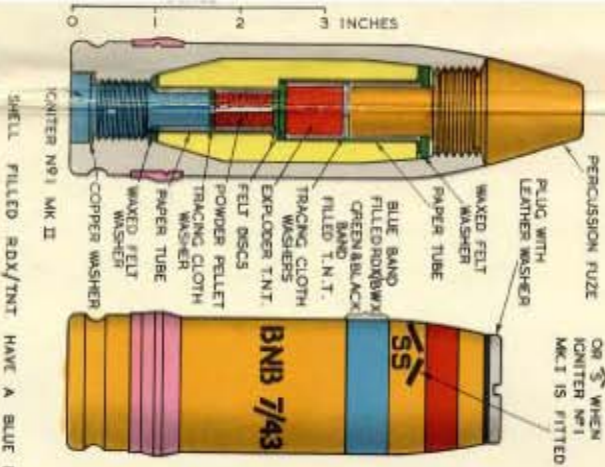

SHELL, O.F. HIGH EXPLOSIVE,
2 PDR. HV

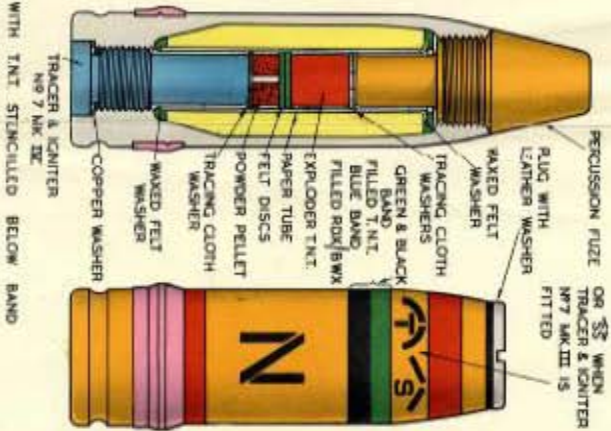

SHELL, O.F. HIGH EXPLOSIVE,
40 MM.

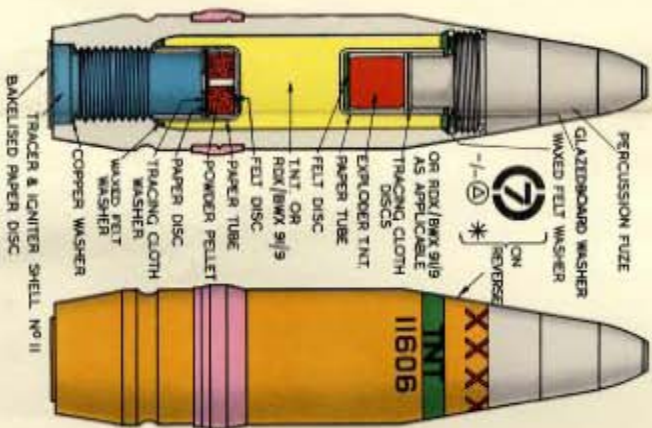

PROJ. PRACTICE, TRACER, O.F.
40 MM.

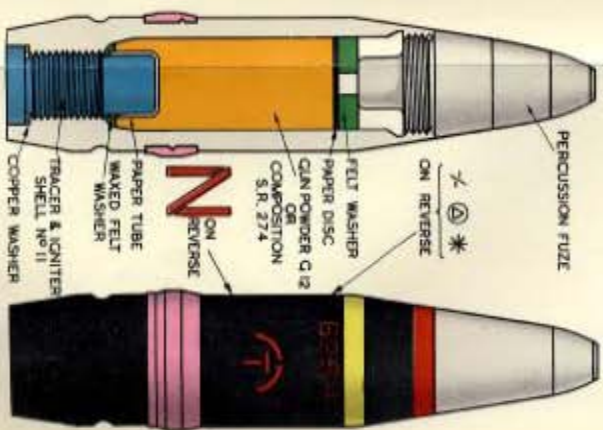

* MONOGRAM OF FIRM OR STATION FILLING
-/- DATE OF FILLING (MONTH & YEAR)

SHELL Q.F. STAR, 4 INCH, FA, 35 LB. MARK IB

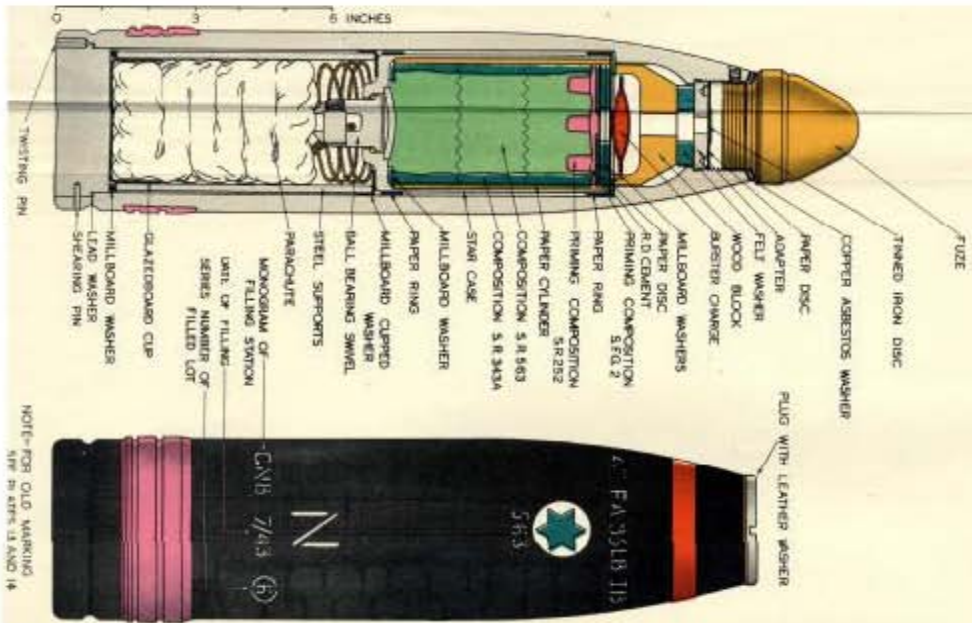

NOTE—FOR OLD MARKING SEE IN ARTS. 13 AND 14

SHELL Q.F. SMOKE, B.E., 4.7 INCH, HEAVY MARK IA

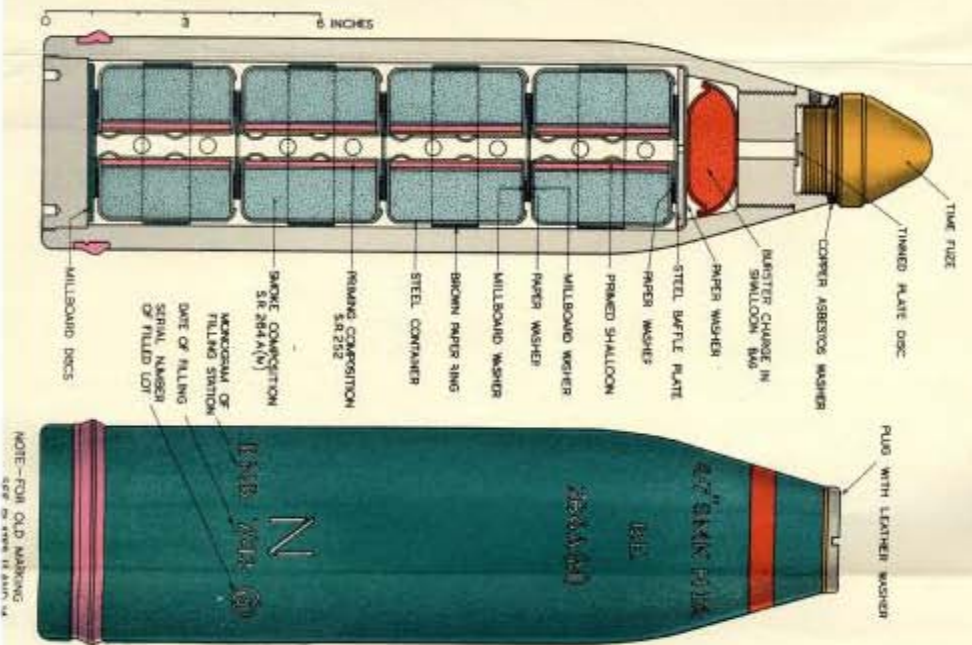

NOTE—FOR OLD MARKING SEE IN ARTS. 13 AND 14

SHELL Q.F. SHRAPNEL 12 PDR. MARK XIII

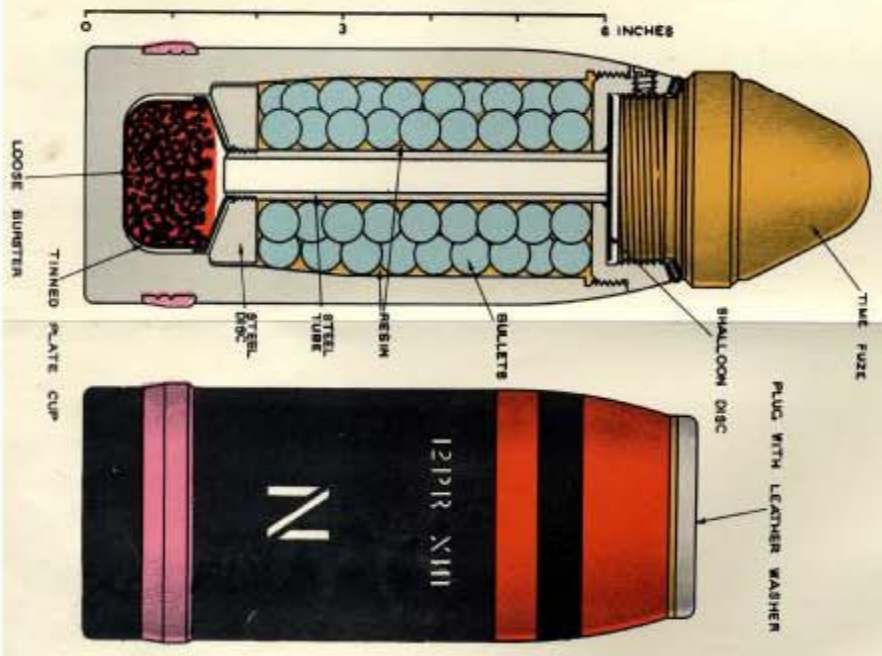

COLOURING OF PROJECTILES

OLD METHOD

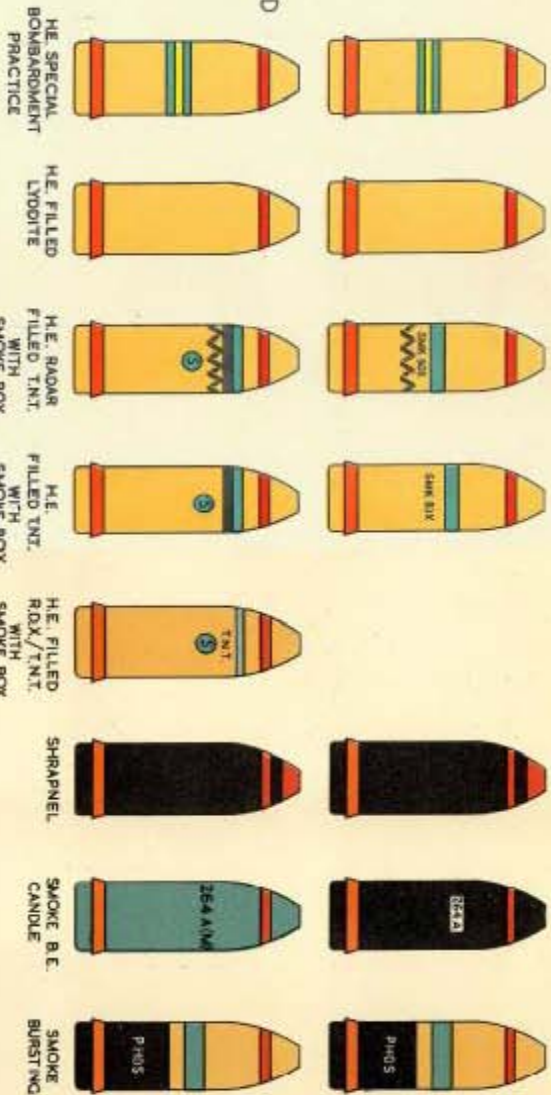

PRESENT METHOD

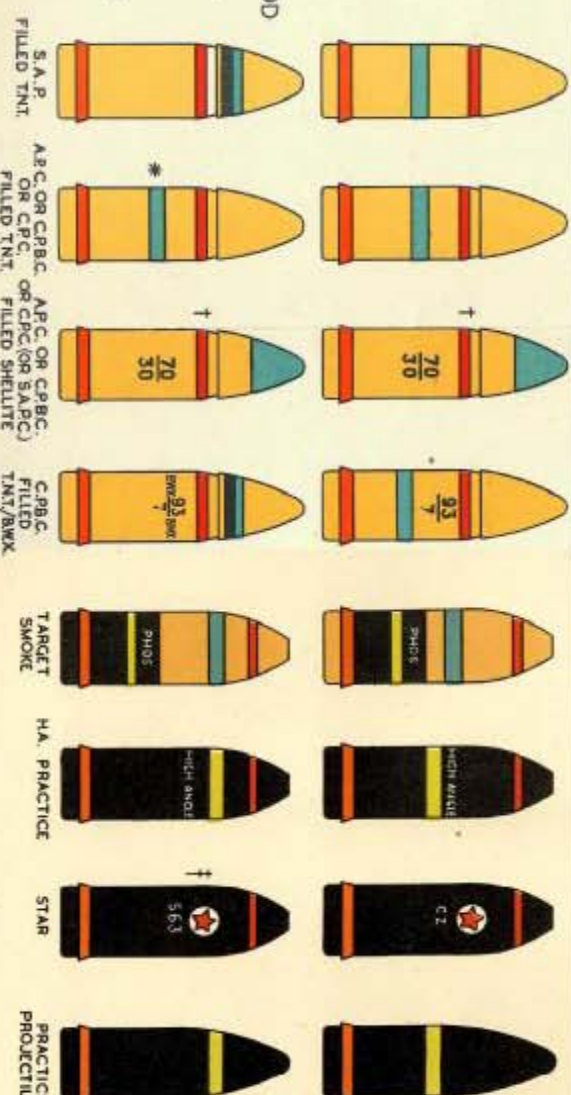

* SOME C.P.B.C. OR C.P.C. SHELL HAVE A GREEN & BLACK BAND ON BODY OR CAP

† S.A.P.C. SHELL HAVE A WHITE BAND ABOVE TAIL RED BAND

‡ GREEN STAR FOR SHELL WITH 27 INCH MATED PARACHUTE

FUZE MARKINGS ON BASE PLATE 13

SCREWED RING AND GASCHECK COVER PLATE FOR FUZE N°158A OR N° 159



SCREWED RING AND GASCHECK COVER PLATE FOR FUZE N°56 GREEN BAR ALSO APPLIES WHEN FUZES N°345 OR N°479 ARE FITTED



SCREWED RING AND TRACER SHELL N° 8 FOR FUZE N°346 OR N° 345A



SCREWED RING AND GASCHECK COVER PLATE FOR FUZE N°159 OR 158 A



COLOUR OF SCREWED RING	N° OF FUZE FITTED
WHITE	158 158A OR 159
YELLOW	345 345A OR 346
BLUE	479 479A OR 480

SCREWED RING AND GASCHECK COVER PLATE FOR FUZE N°502



COLOUR OF BAR	N° OF FUZE FITTED
WHITE	501
GREEN	500 OR 501
YELLOW	502

STENCILLING ON SHELL OLD METHOD

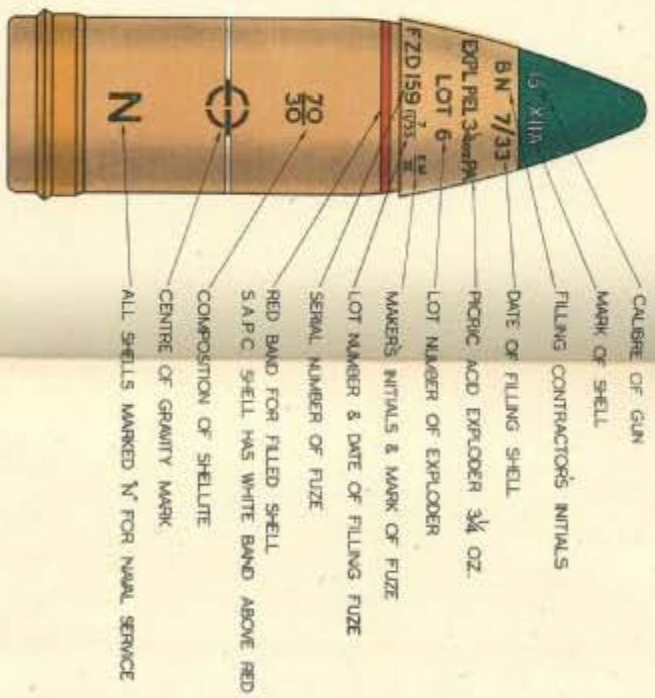

- CALIBRE OF GUN
- MARK OF SHELL
- FILLING CONTRACTOR'S INITIALS
- DATE OF FILLING SHELL
- PICRIC ACID EXPLODER 3 1/4 OZ.
- LOT NUMBER OF EXPLODER
- MAKER'S INITIALS & MARK OF FUZE
- LOT NUMBER & DATE OF FILLING FUZE
- SERIAL NUMBER OF FUZE
- RED BAND FOR FILLED SHELL
- S.A.P.C. SHELL HAS WHITE BAND ABOVE RED
- COMPOSITION OF SHELLITE
- CENTRE OF GRAVITY MARK
- ALL SHELLS MARKED 'N' FOR NAVAL SERVICE

TYPICAL BASE FUZED SHELL
A.P.C. C.P.C. OR C.P.B.C. FILLED SHELLITE

STENCILLING ON SHELL PRESENT METHOD

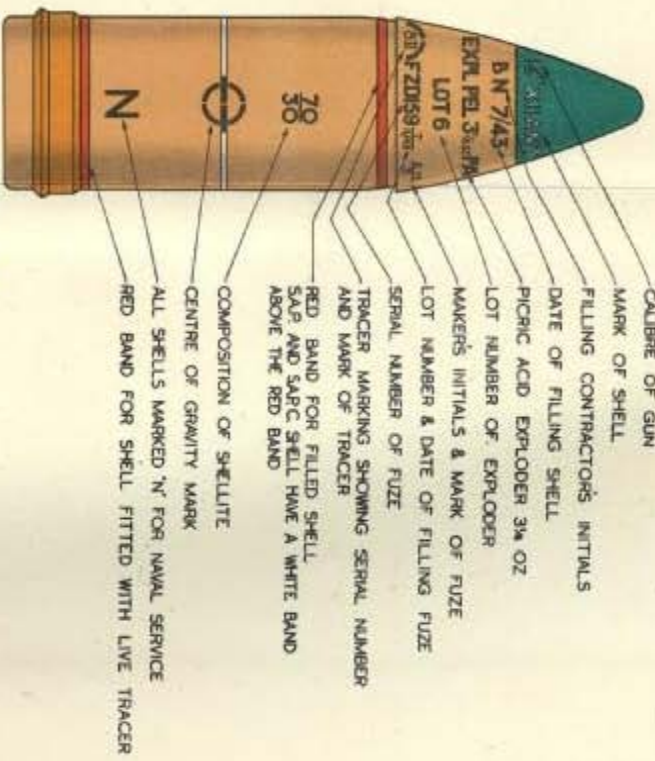

- CALIBRE OF GUN
- MARK OF SHELL
- FILLING CONTRACTOR'S INITIALS
- DATE OF FILLING SHELL
- PICRIC ACID EXPLODER 3 1/4 OZ.
- LOT NUMBER OF EXPLODER
- MAKER'S INITIALS & MARK OF FUZE
- LOT NUMBER & DATE OF FILLING FUZE
- SERIAL NUMBER OF FUZE
- TRACER MARKING SHOWING SERIAL NUMBER AND MARK OF TRACER
- RED BAND FOR FILLED SHELL
- S.A.P.C. AND S.A.P.C. SHELL HAVE A WHITE BAND ABOVE THE RED BAND
- COMPOSITION OF SHELLITE
- CENTRE OF GRAVITY MARK
- ALL SHELLS MARKED 'N' FOR NAVAL SERVICE
- RED BAND FOR SHELL FITTED WITH LIVE TRACER

TYPICAL BASE FUZED SHELL
A.P.C. C.P.C. OR C.P.B.C. FILLED SHELLITE

- RED BAND FOR FILLED SHELL
- PROJECTILES FITTED FOR TRACERS ARE STENCILED AS FOLLOWS:—
- WHEN PREPARED FOR TRACER
- WHEN FITTED WITH NIGHT TRACER
- WHEN FITTED WITH W.P.2 MAKE TRACER

- GREEN BAND FOR SHELL FILLED TNT
- CENTRE OF GRAVITY MARK
- FILLING CONTRACTOR'S INITIALS
- DATE OF FILLING SHELL
- PELLET EXPLODER
- COMPOSITION EXPLODING 26 DRS

TYPICAL NOSE FUZED SHELL
HE FILLED TNT



- RED BAND FOR FILLED SHELL
- PROJECTILES FITTED FOR TRACERS ARE STENCILED AS FOLLOWS:—
- WHEN PREPARED FOR TRACER
- WHEN FITTED WITH TRACER
- WHEN FITTED WITH DIM IGNITION TRACER

- GREEN & BLACK BANDS FOR SHELL FILLED TNT
- CENTRE OF GRAVITY MARK
- FILLING CONTRACTOR'S INITIALS
- DATE OF FILLING SHELL
- PELLET EXPLODER
- COMPOSITION EXPLODING 26 DRS
- RED BAND FOR SHELL FITTED WITH LIVE TRACER

TYPICAL NOSE FUZED SHELL
HE FILLED TNT



TRACER SHELL N°1 MARK VIIA EXTERNAL

(SCALE APPROXIMATELY 1/12)

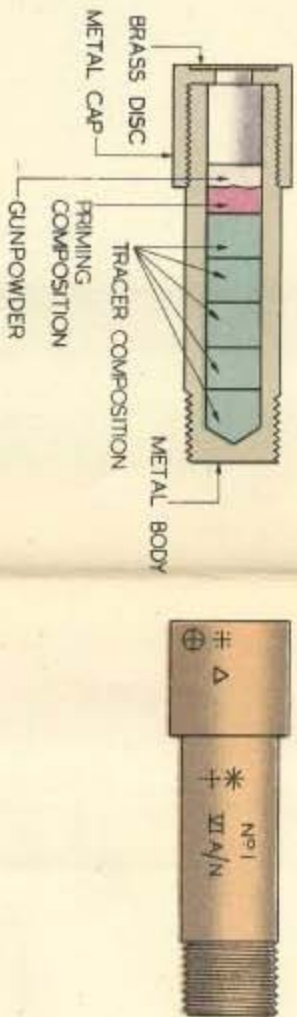

TRACER SHELL N°2 MARK VA INTERNAL

(SCALE APPROXIMATELY 1/12)

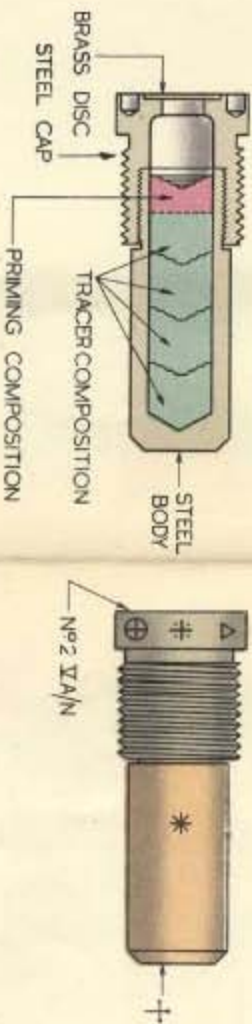

TRACER SHELL N°8 MARK I

(SCALE APPROXIMATELY 2/3)

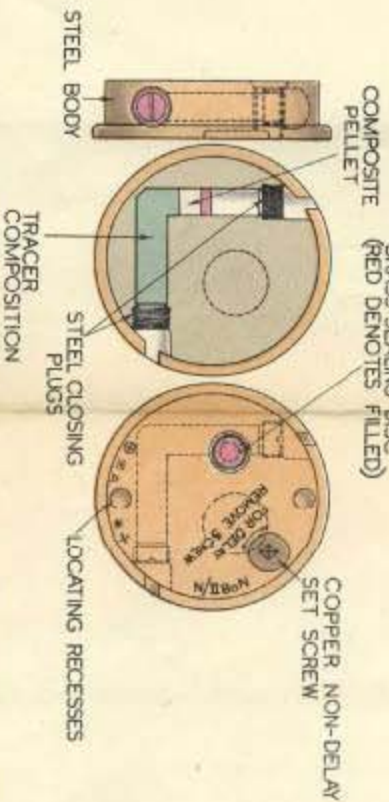

IGNITER SHELL N°1 MARK I

(SCALE APPROXIMATELY 1/12)

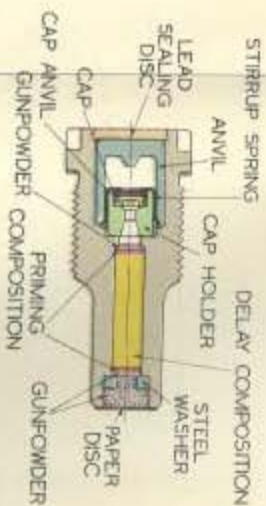

TRACER AND IGNITER SHELL N°7 MARK IV INTERNAL

(SCALE APPROXIMATELY 1/12)

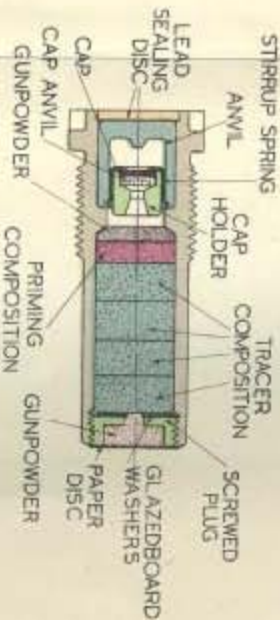

- * CONTRACTOR'S INITIALS OR RECOGNISED TRADE MARK
- †† DATE OF MANUFACTURE MONTH AND YEAR
- ††† MONOGRAM OF FILING STATION
- ⊕ FILLED LOT NUMBER
- △ FILLED LOT NUMBER

FLAT BASE TRACER
FACES OF PLUGS AND SEALING DISC
PAINTED RED AFTER FILING

FUZE PERCUSSION
D.A. NO 44 MARK X WITH CAP

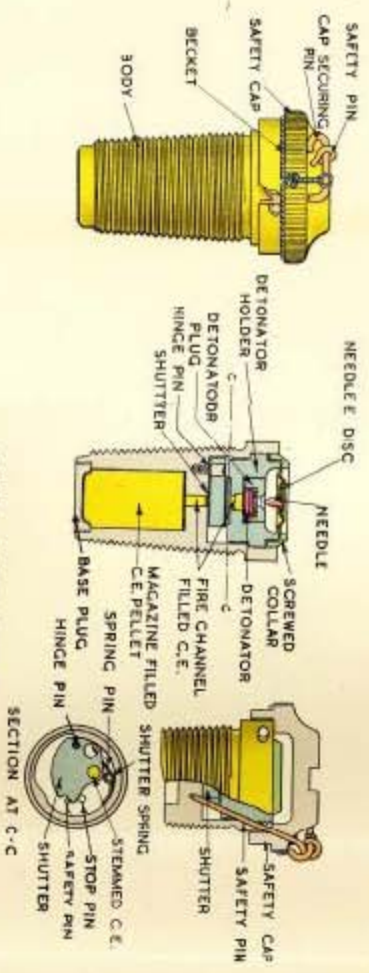

FUZE PERCUSSION
D.A. NO 45 P MARK X WITH CAP

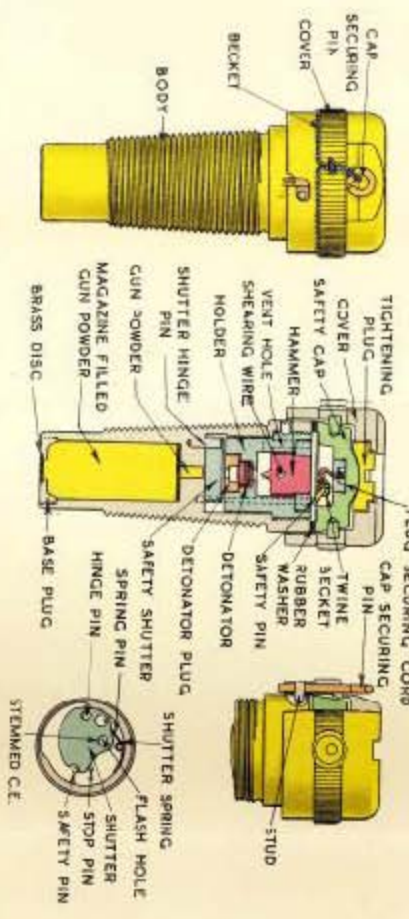

FUZE PERCUSSION
D.A. NO 118 MARK II

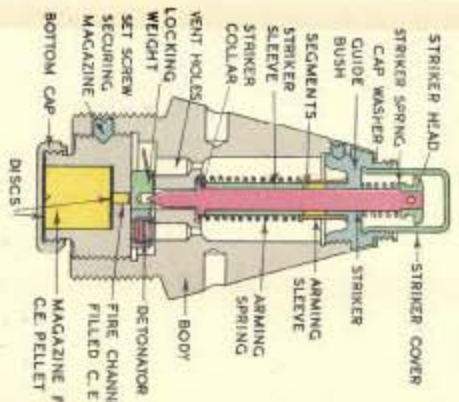

FUZE PERCUSSION
D.A. NO 230 MARK V

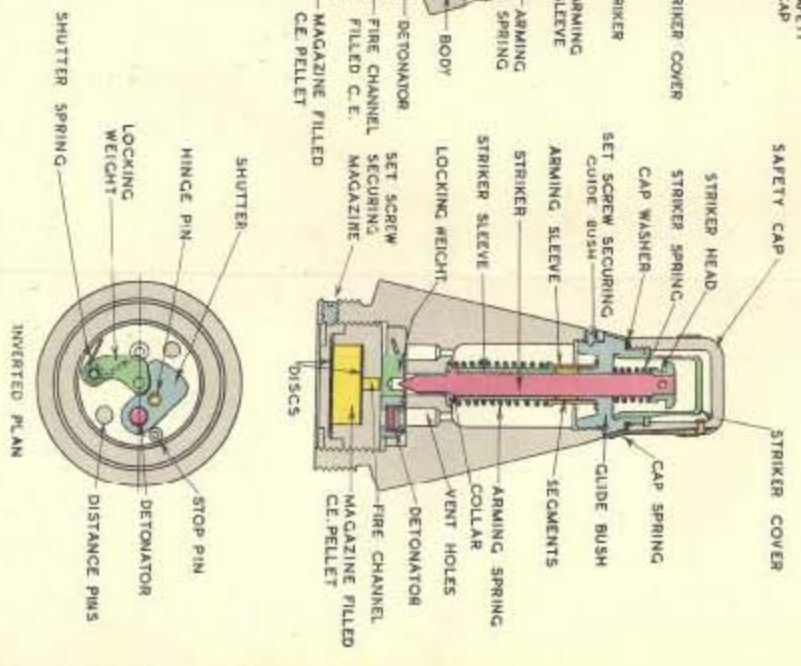

SCALE: FULL SIZE

FUZE, PERCUSSION
D. A. NO. 241 MARK I

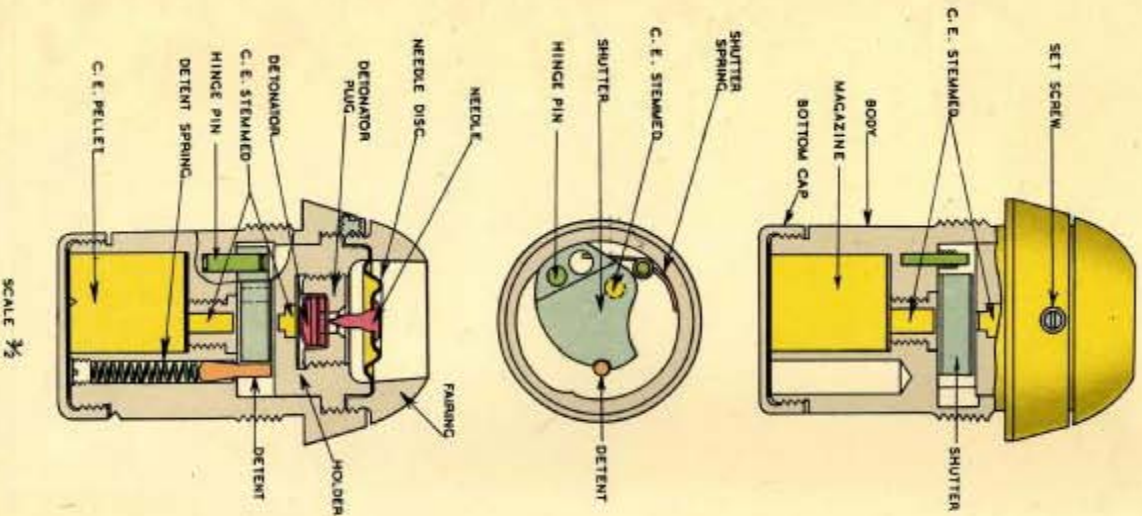

FUZE, PERCUSSION
D. A. NO. 246 MARK I

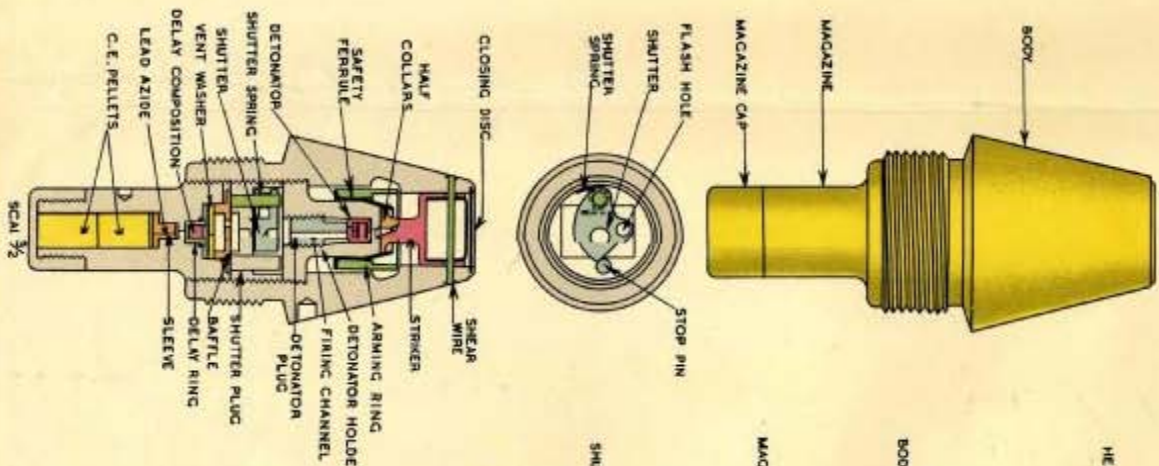

FUZE, PERCUSSION
D. A. NO. 255 MARK I

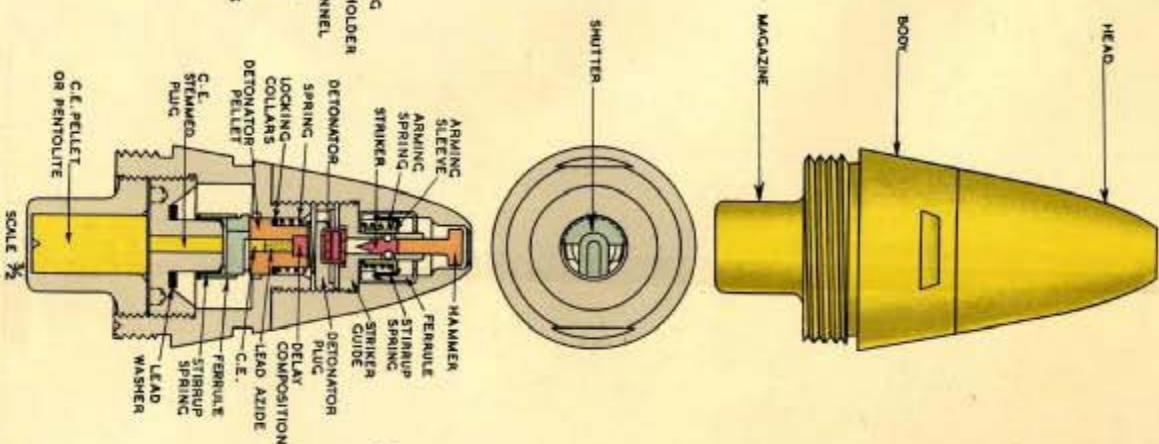

FUZE, TIME AND PERCUSSION
EO. 93 MARK I

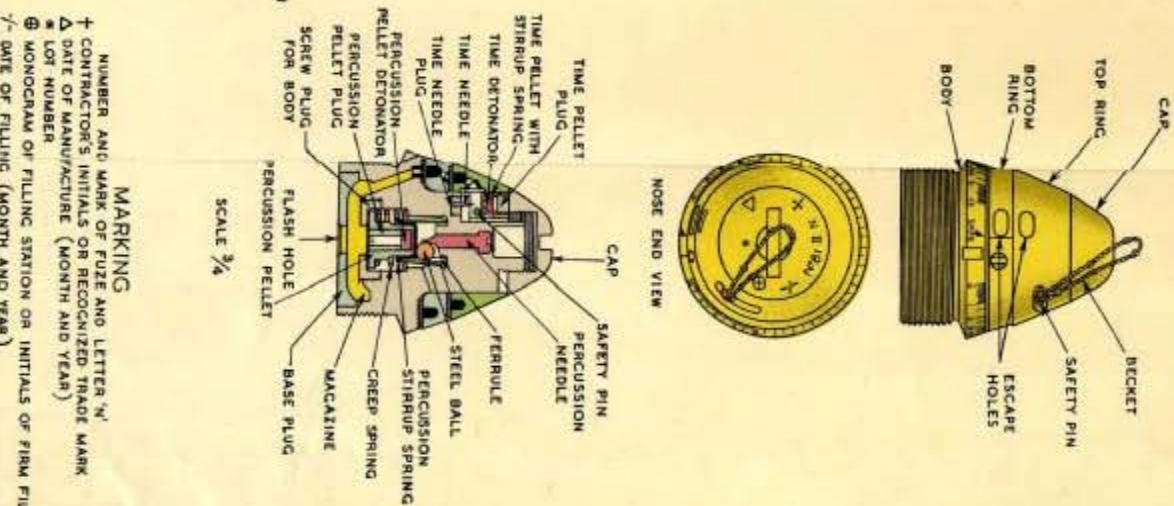

MARKING
 NUMBER AND MARK OF FUZE AND LETTER 'N'
 + CONTRACTOR'S INITIALS OR RECOGNIZED TRADE MARK
 Δ DATE OF MANUFACTURE (MONTH AND YEAR)
 * LOT NUMBER
 ⊕ MONOGRAM OF FILLING STATION OR INITIALS OF FIRM FILLING
 -/ DATE OF FILLING (MONTH AND YEAR)

SCALE 3/2

SCALE 3/2

SCALE 3/2

SCALE 3/4

FUZE, PERCUSSION
BASE, HOTCHKISS
MARK IX

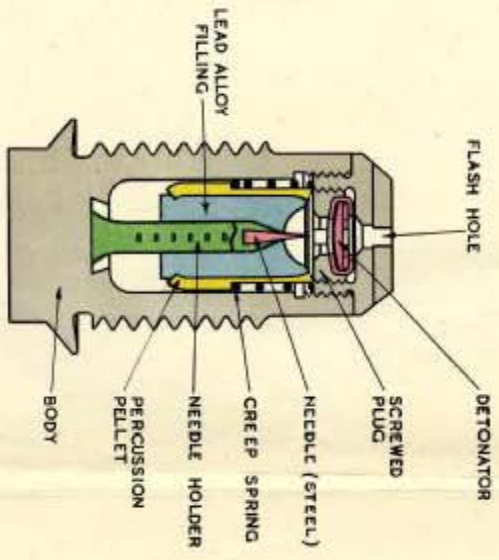
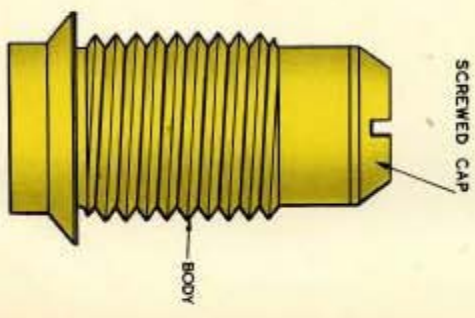

SCALE 3/4

FUZE, PERCUSSION, BASE, MEDIUM
No 501 MARK I

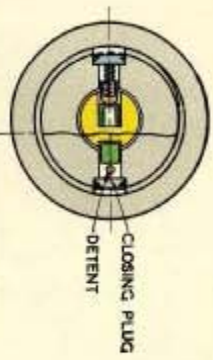
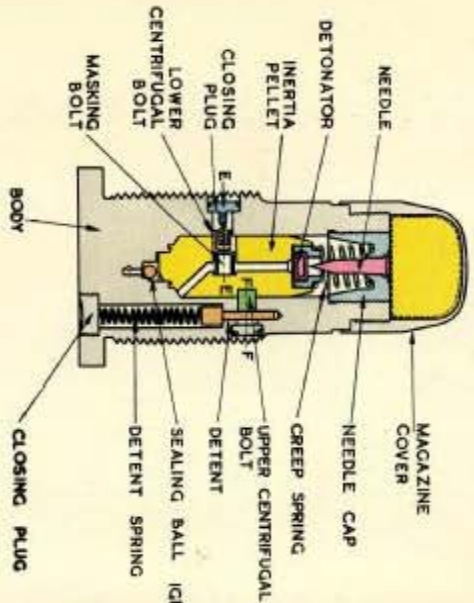

PART SECTION E E, PART SECTION F F

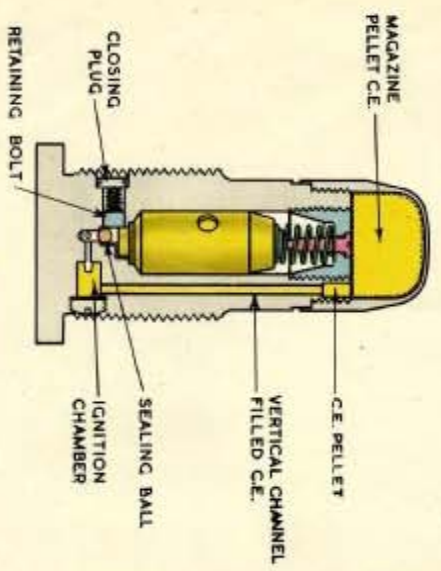

SCALE 3/4

FUZE, PERCUSSION, BASE, LARGE
No 480 MARK II

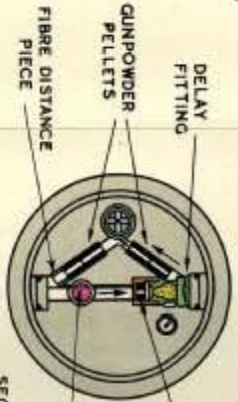
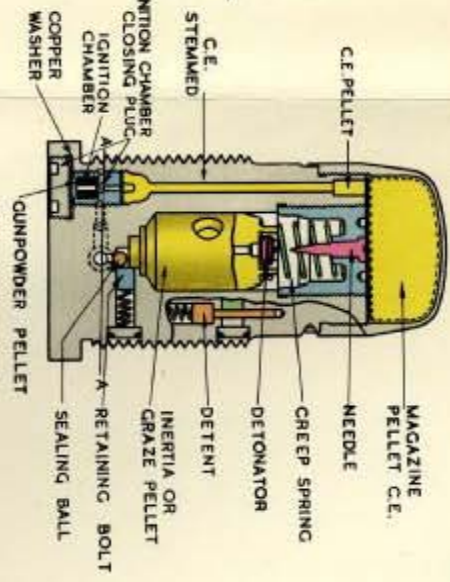

SECTION A-A SECTION OF PRESSURE PLATE

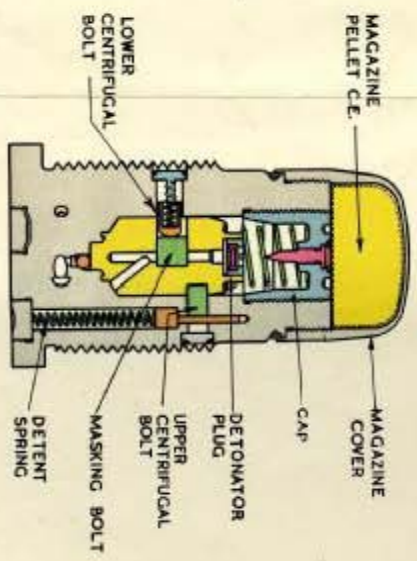
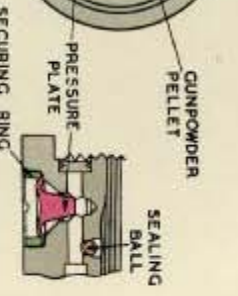

SCALE 3/4

FUZE, TIME, NO. 125 MARK I

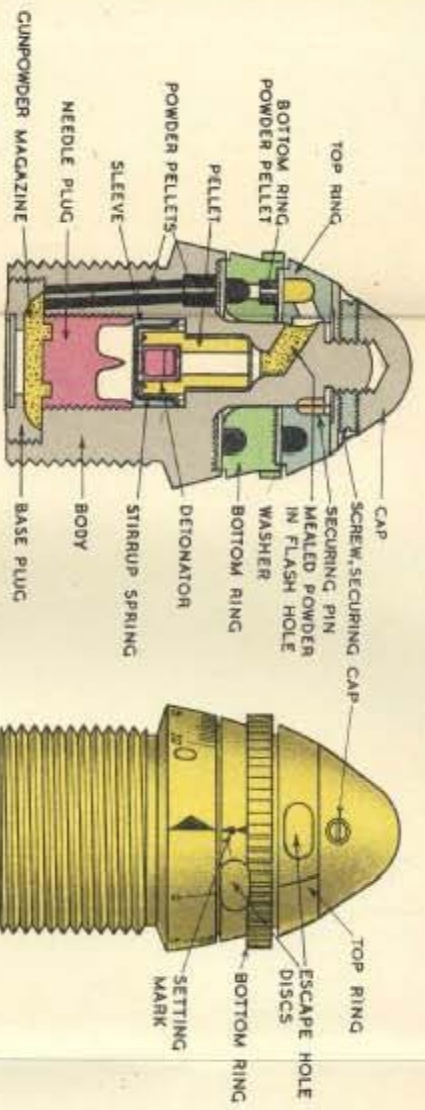

SCALE 3/2

GAINIE NO. 10. MARK I

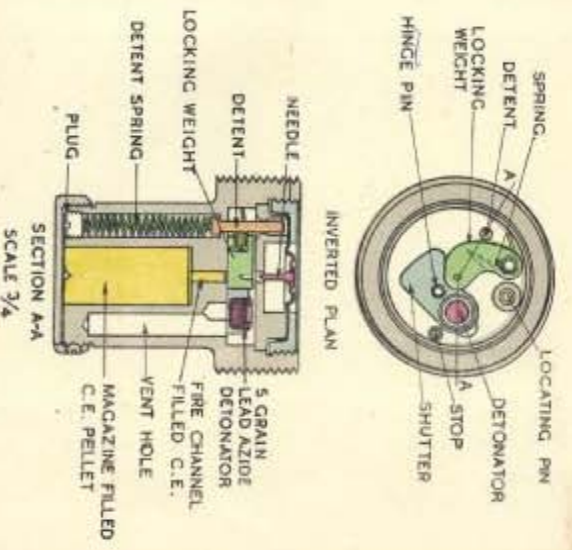

SECTION A-A
SCALE 3/4

FUZE, TIME, NO. 198 MARK II

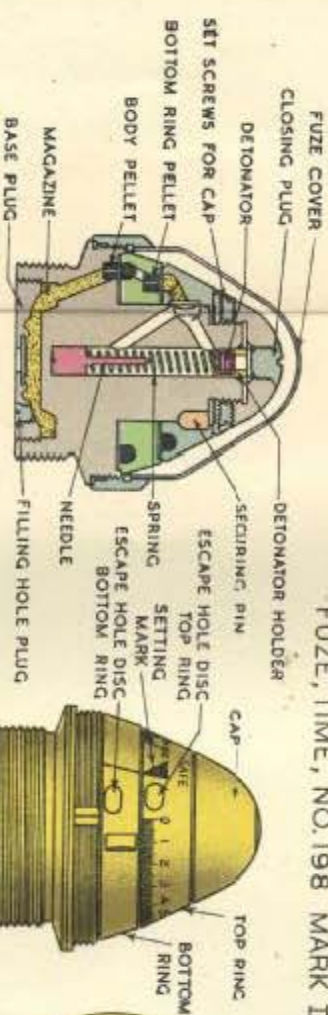

SCALE 3/4



NOSE END VIEW

† CONTRACTORS INITIALS OR REGISTERED TRADE MARK
 Δ DATE OF MANUFACTURE
 * LOT NUMBER
 ○ MONOGRAM OF FILLING STATION
 ¼ DATE OF FILLING (MONTH AND YEAR)

FUZE, TIME, NO. 402 MARK I

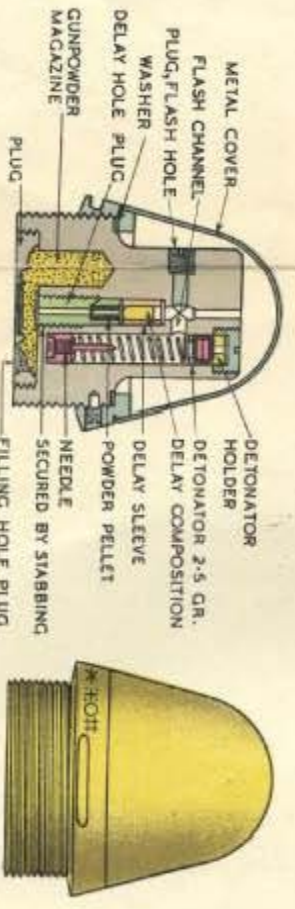

SCALE 3/4

GAINIE NO. 11. MARK II Z.Y.

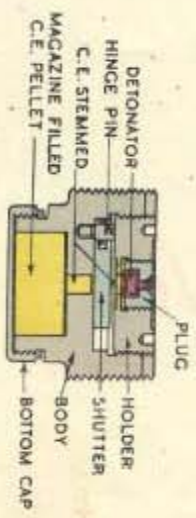

SCALE 3/4

RIFLE AND MACHINE-GUN CARTRIDGES



0.30 BALL
(AMERICAN MANUFACTURE)



0.303 BALL MARK VIII Z



0.50 BALL VICKERS MARK II Z



0.50 BALL BROWNING
(AMERICAN MANUFACTURE)

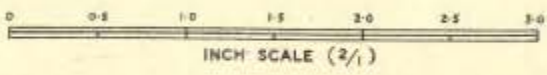
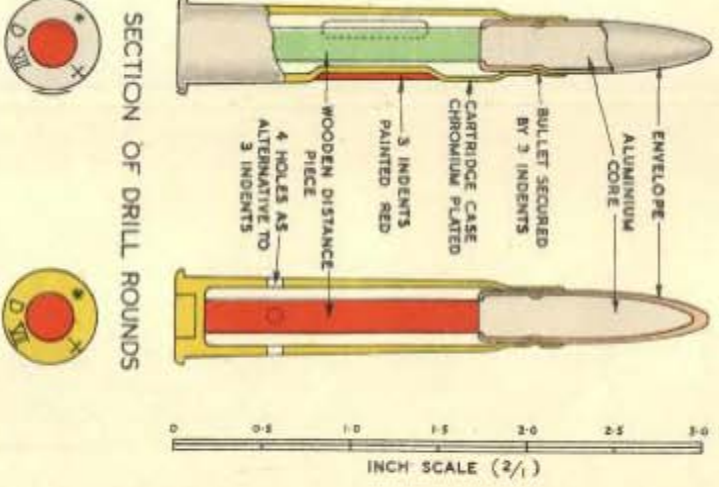
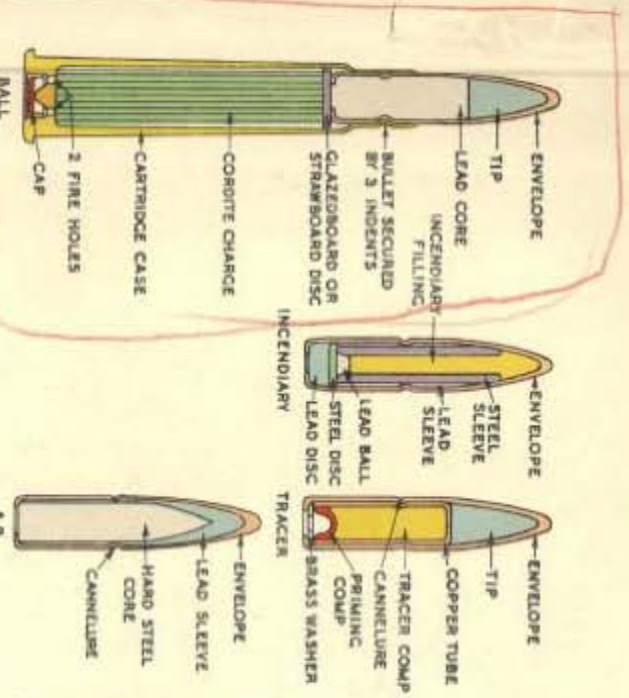

* CONTRACTOR'S INITIALS OR TRADE MARK
+ YEAR OF MANUFACTURE

REVOLVER, PISTOL AND MACHINE CARBINE AMMUNITION

SCALE 2/1

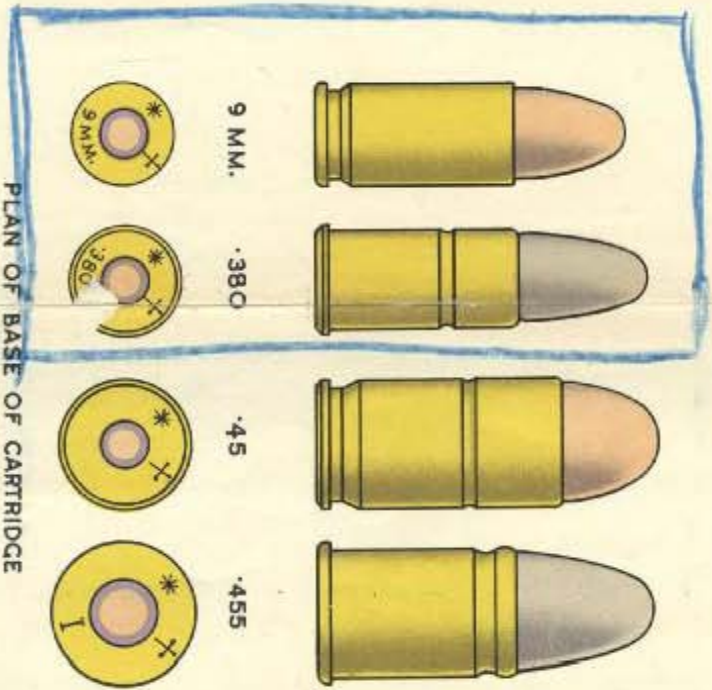
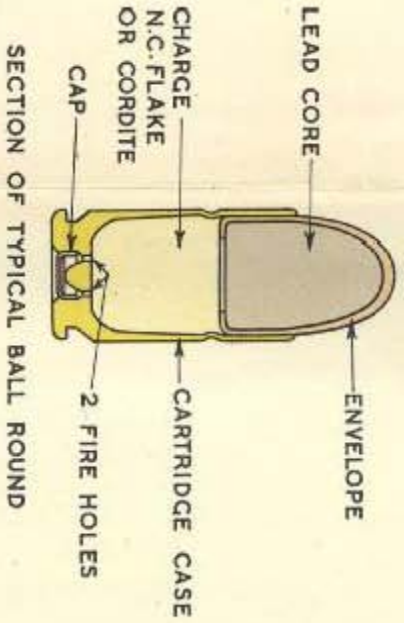

* CONTRACTOR'S INITIALS OR TRADE MARK + YEAR OF MANUFACTURE

CARTRIDGE AIMING RIFLE 1-INCH

SECTION OF ROUND AND ELECTRIC AND PERCUSSION PRIMERS

PRIMERS

SCALE 1/1

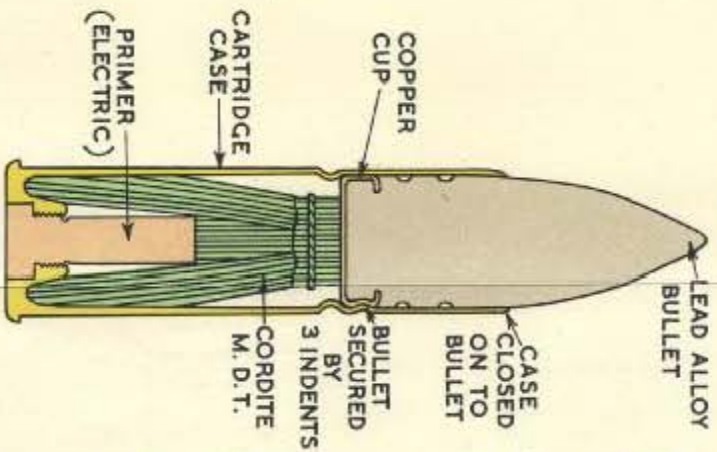

PLAN OF BASE OF CARTRIDGE

SCALE 2/1

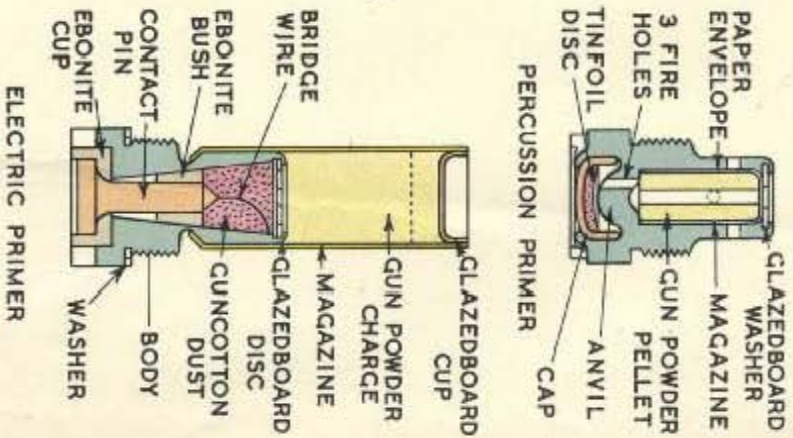

20 M.M. AMMUNITION

ORLIKON. BRITISH AND AMERICAN

COMPLETE ROUNDS

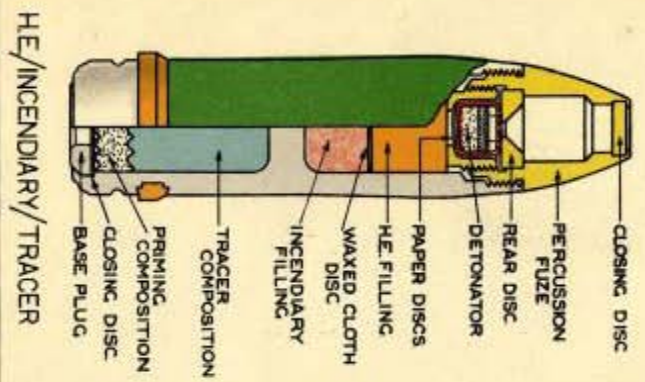
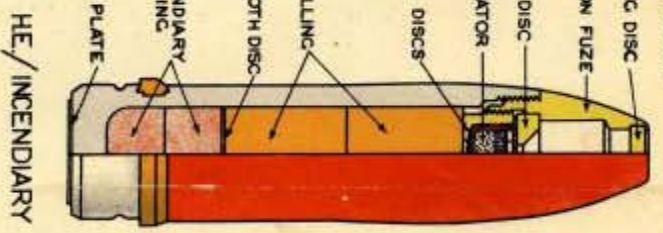
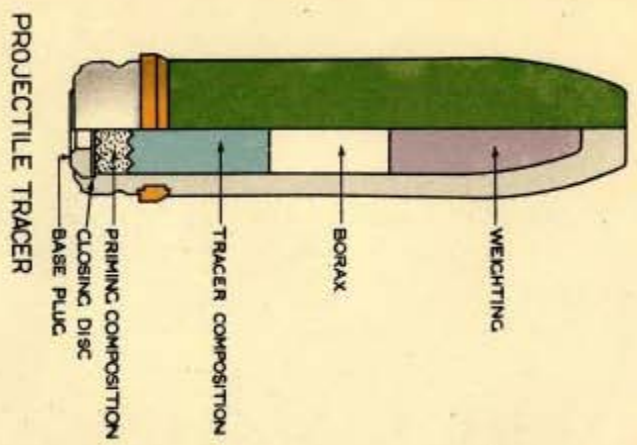

COLOUR IDENTIFICATION

BRITISH		AMERICAN	
NATURE OF SHELL	HE FILLING COLOUR	NATURE OF SHELL	HE FILLING COLOUR
H.E. TRACER	T.N.T.	H.E. TRACER	TETRYL
H.E.	T.N.T.	H.E. TRACER	PENTOLITE
PROJ. PRACTICE		H.E.	TETRYL
PROJ. TRACER		H.E.	PENTOLITE
H.E. INCENDIARY	T.N.T.	H.E. INCENDIARY	TETRYL
H. INCENDIARY TRACER	T.N.T.	H.E. INCENDIARY	PENTOLITE

MILLIMETRES
0 10 20

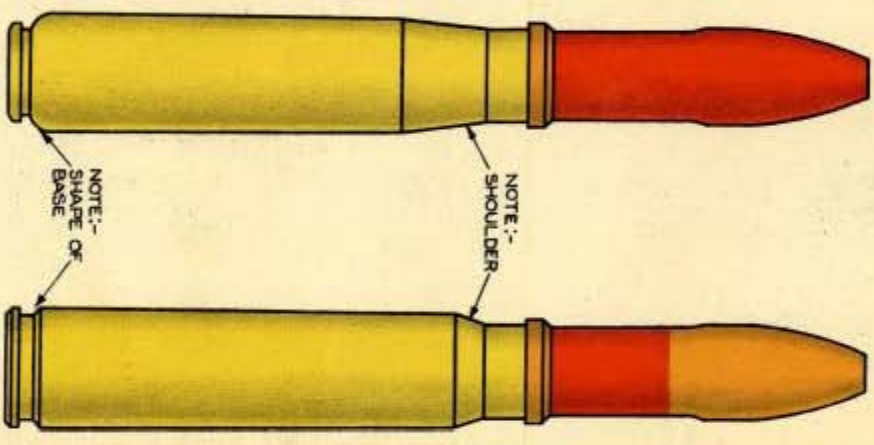

* CONTRACTORS' INITIALS OR TRADE MARK
+ YEAR OF MANUFACTURE

SCALE: FULL SIZE

APPARATUS AD TYPE 'D' (PAC)

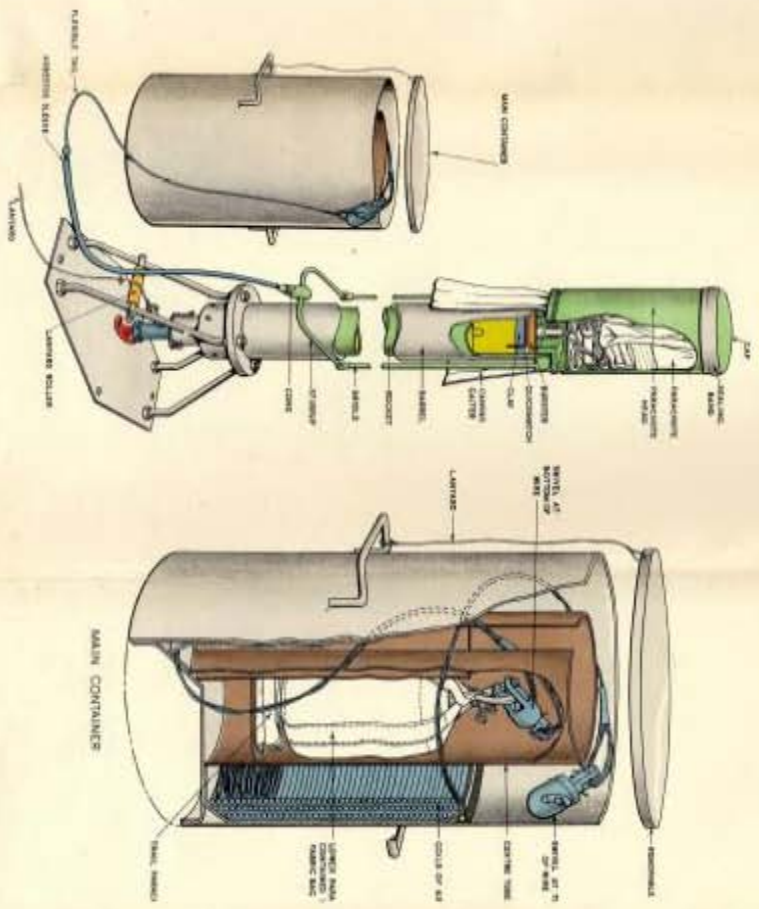

APPARATUS AD TYPE 'J'

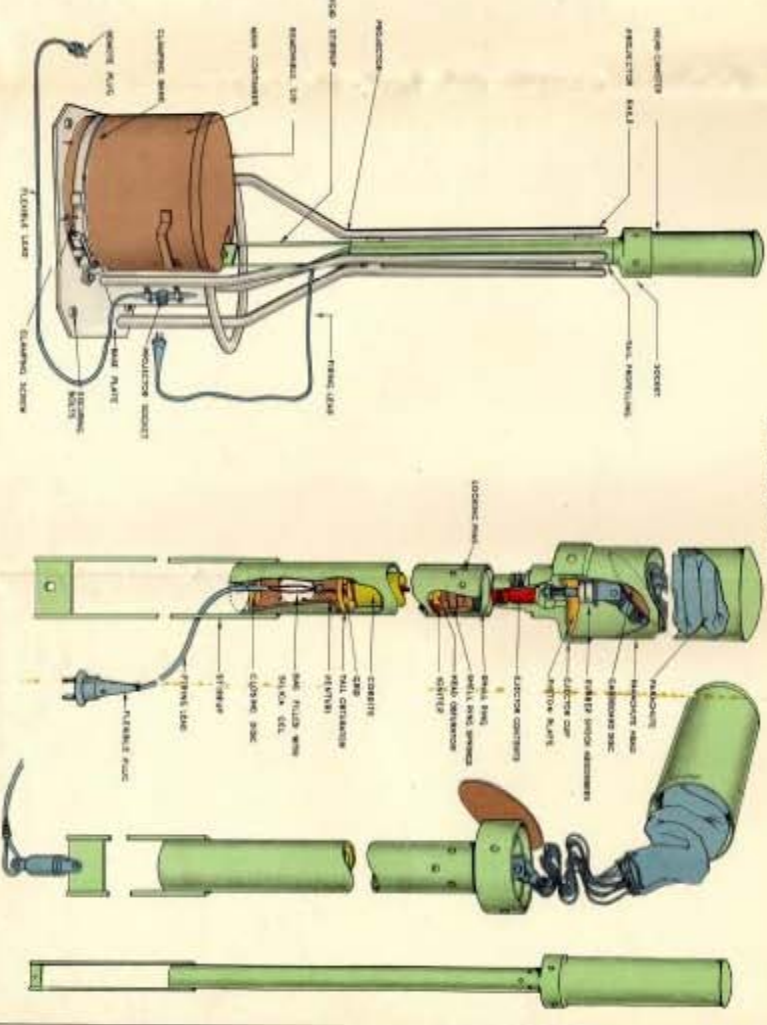

APPARATUS A. D. TYPE T MARK II

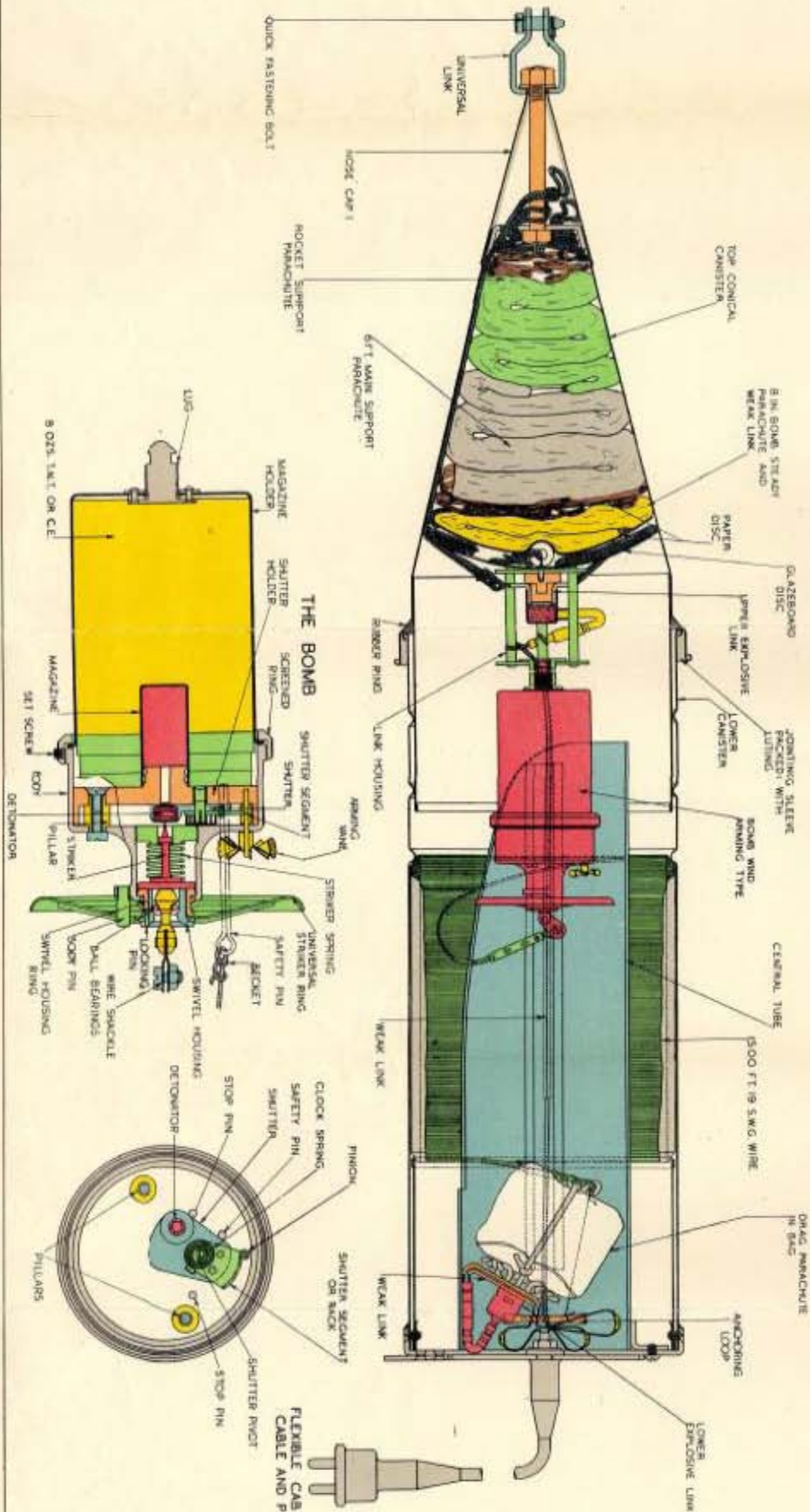

THE BOMB

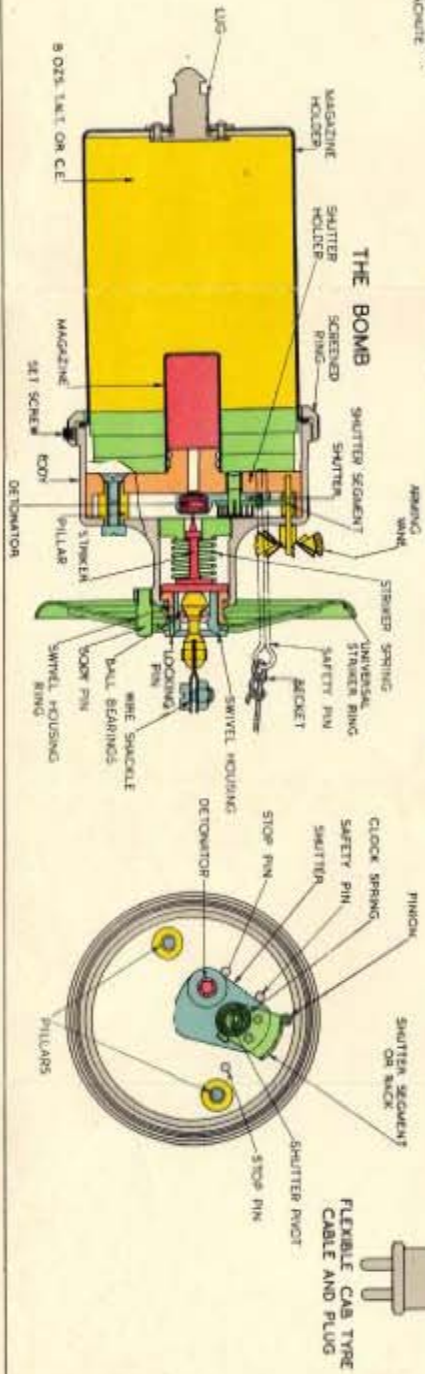

GRENADE NO 36M. MK. I.
(WITH GASCHECK FITTED)

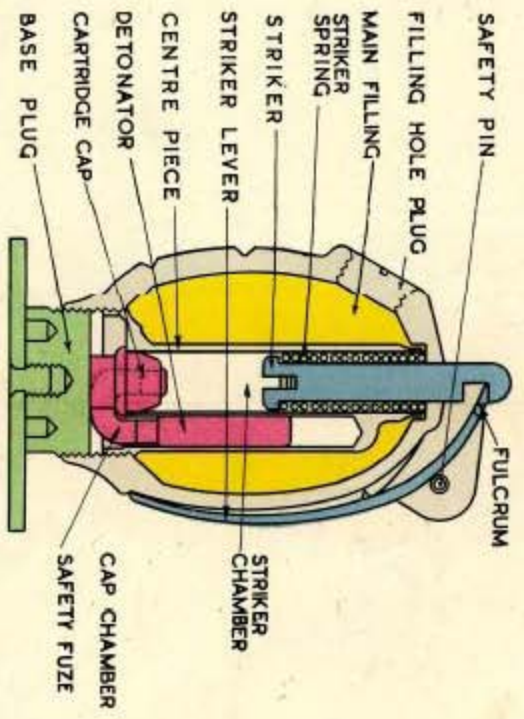
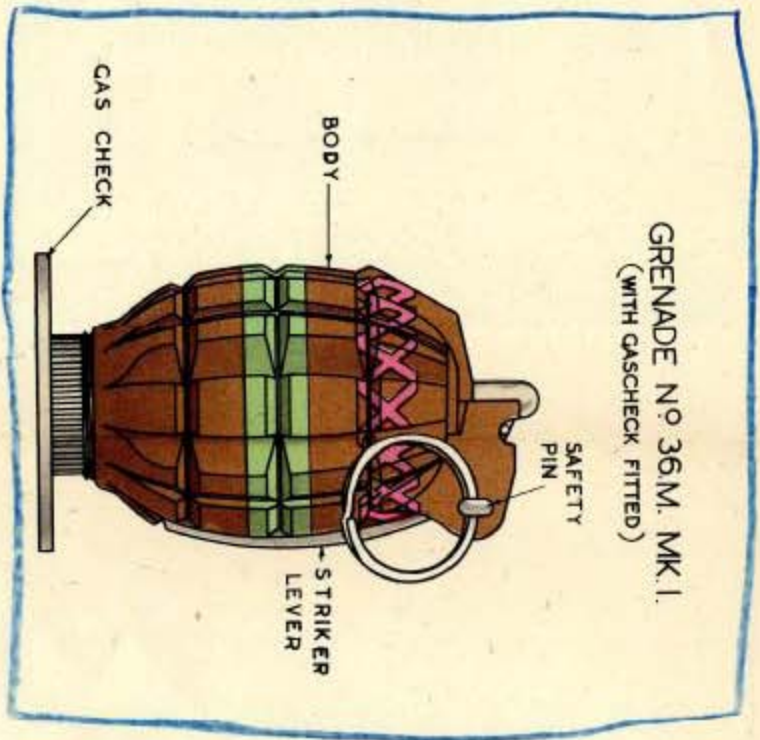

SCALE FULL SIZE

GRENADE NO 69. MK. I.

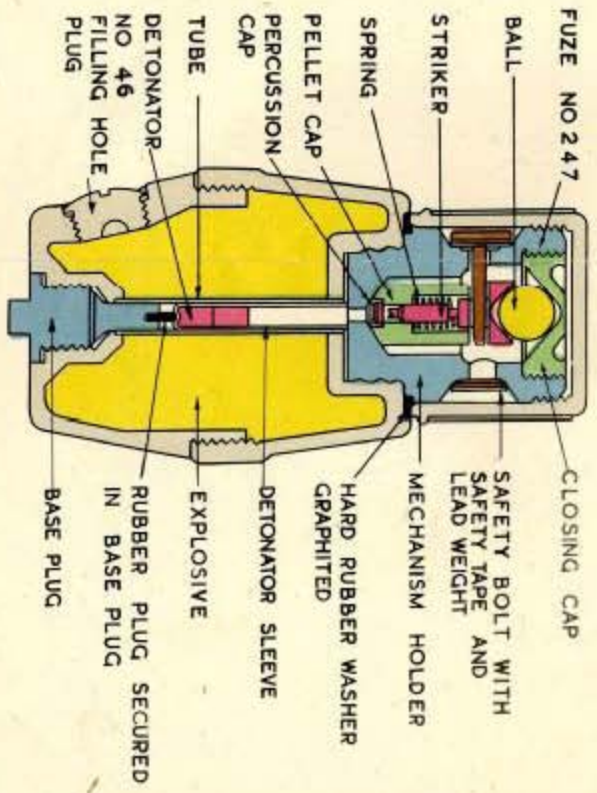
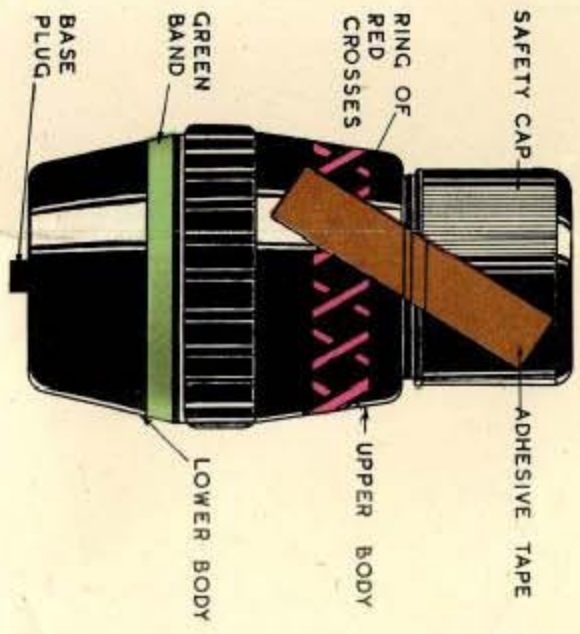

BL 4 INCH MORTAR AMMUNITION

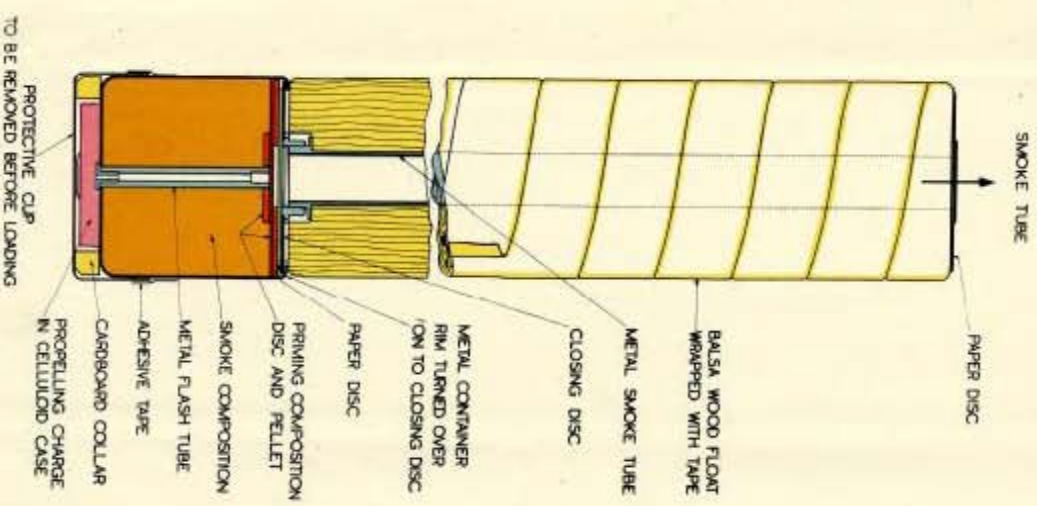

SMOKE FLOAT BL. 4 IN MORTAR MARK III

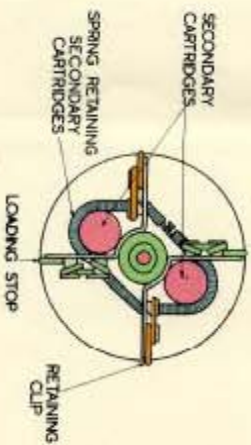
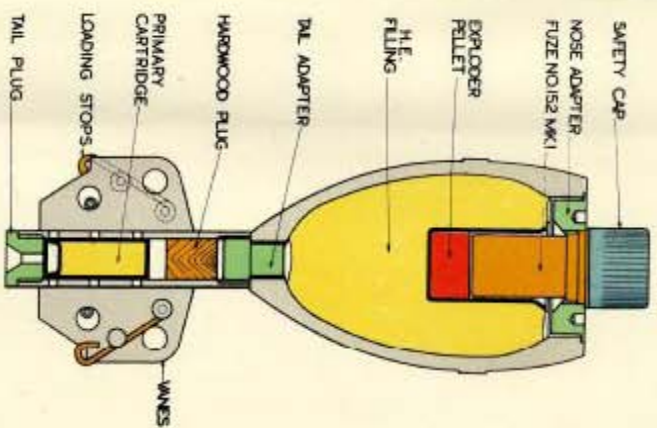

BOMB BL. HE 4 IN MORTAR 10 LB. MARK I

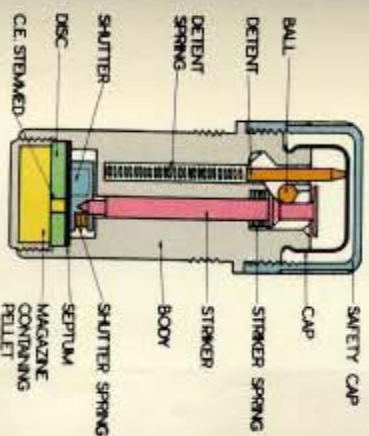
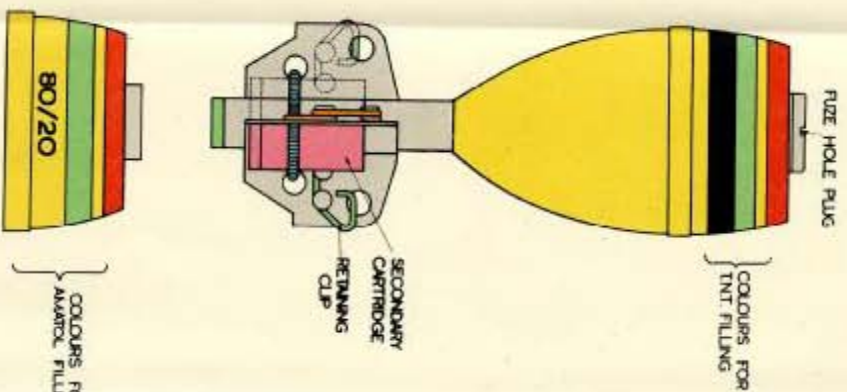

FUZE FOR BOMB BL. HE 4 IN MORTAR 10 LB. (ENLARGED SCALE)

ROCKET, SIGNAL, 1 LB. SERVICE

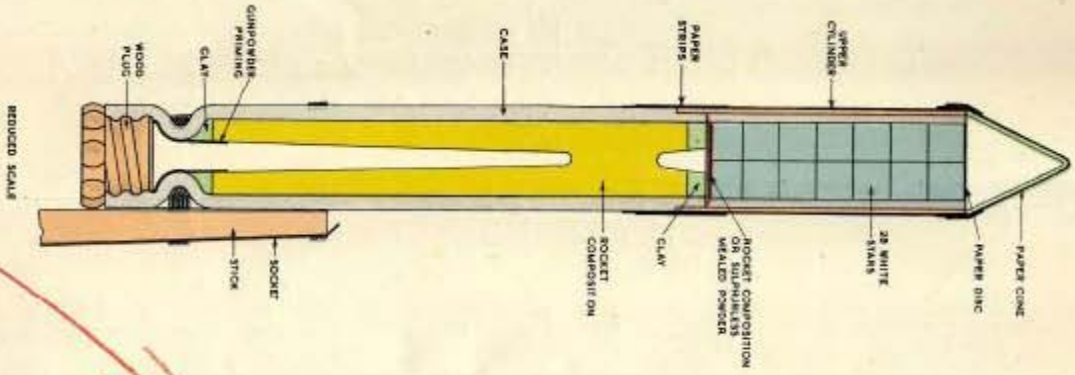

FLARE, SIGNAL, MARK II

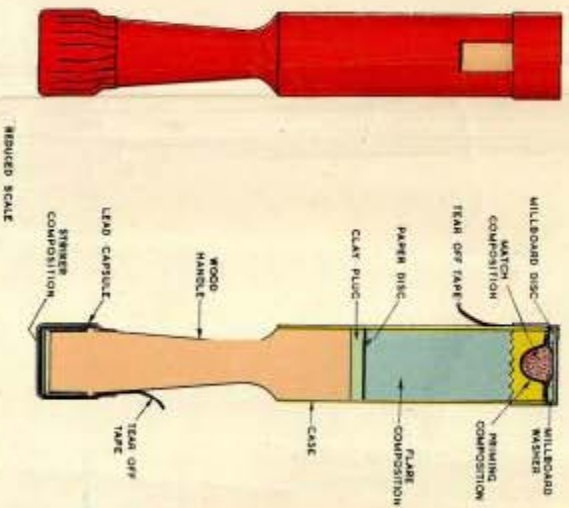

CARTRIDGE, SIGNAL, RED, 1-INCH, MARK XIXT

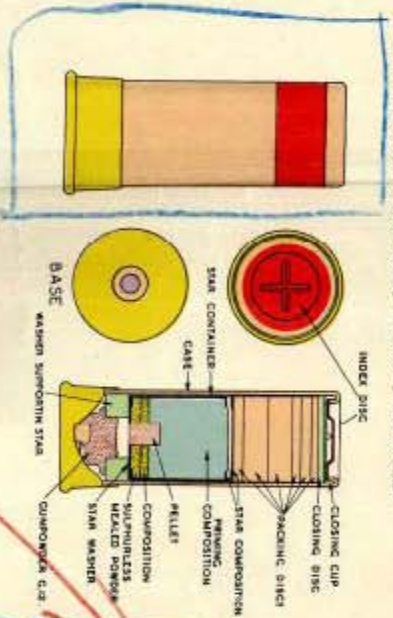

CARTRIDGE, SIGNAL, GREEN, 1-INCH, MARK XI T

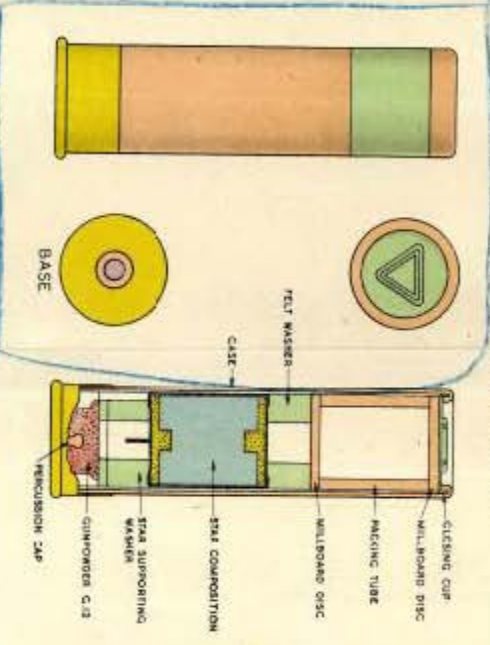

CARTRIDGE, SIGNAL, RED, 1/2 INCH, MARK VT

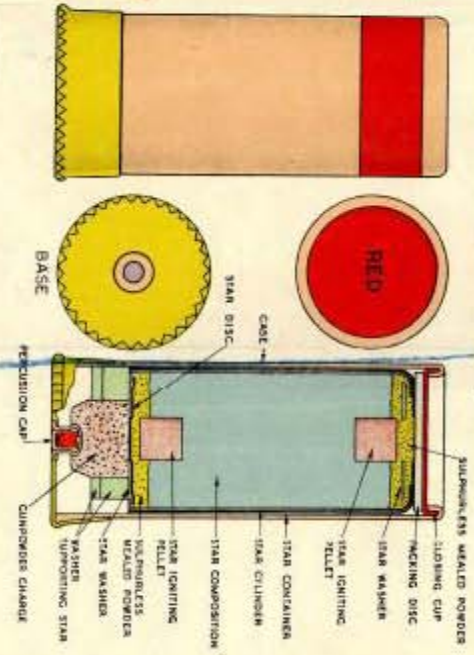

3 INCHES
0 1 2

ROCKET, TARGET, PRACTICE 1 LB. MK II

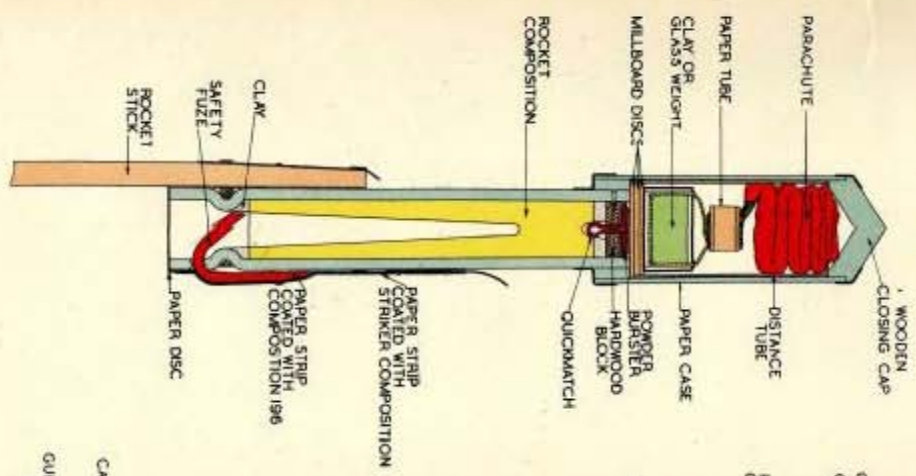

ROCKET, LINE CARRYING, SCHEMULLY 2 LB., MARK I

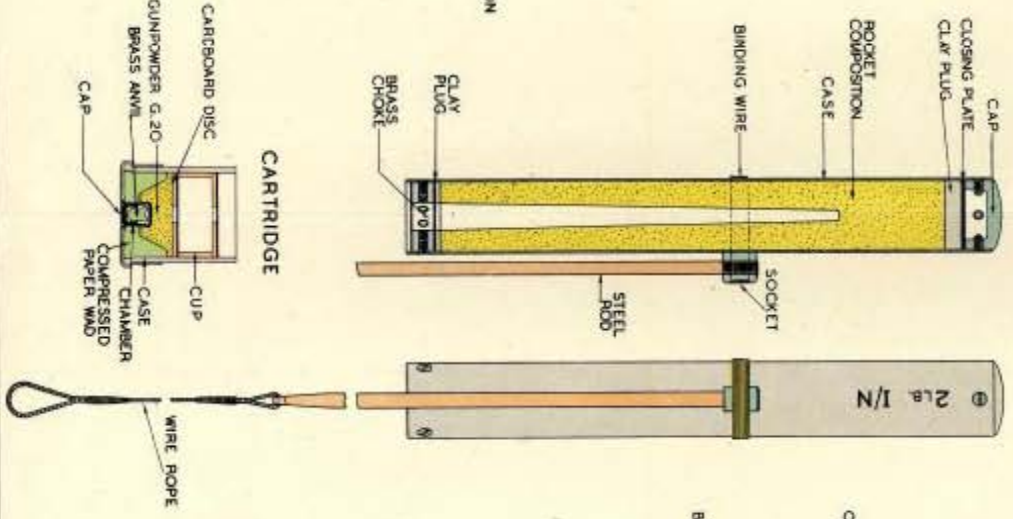

CANDLE SMOKE WHITE MARK I

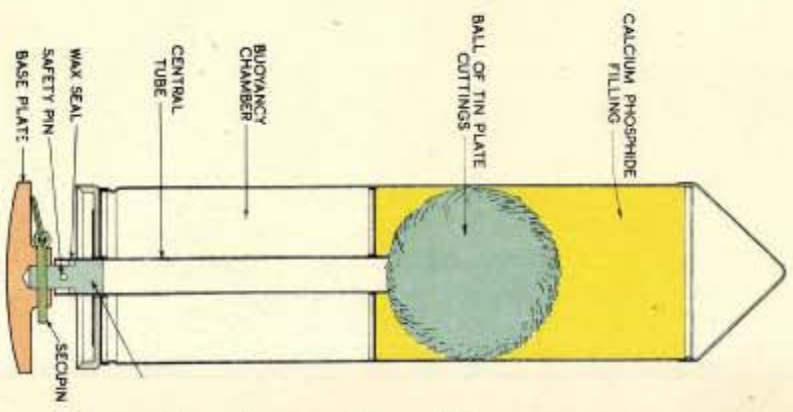

FLAME FLOAT DELAY MARK I/N

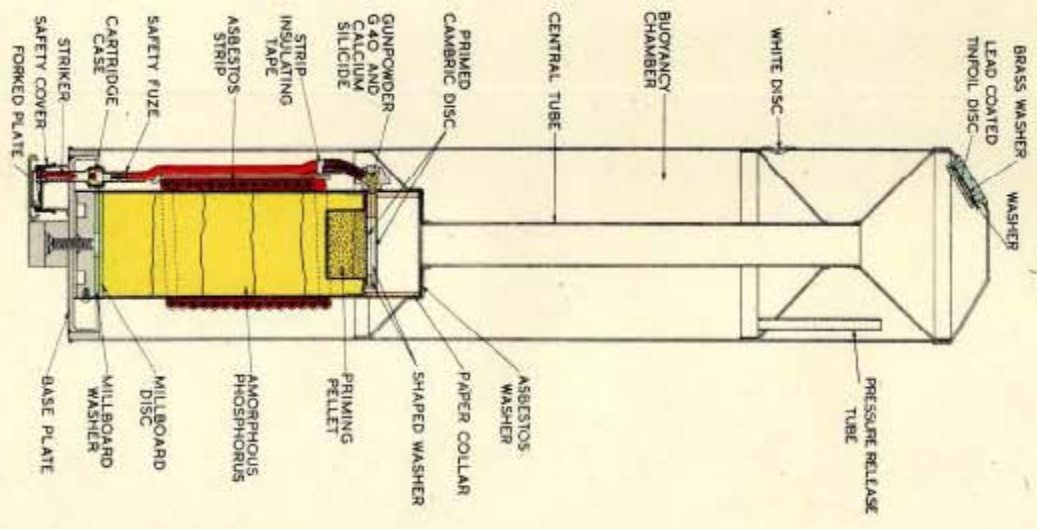

AIRCRAFT BOMBS

SAFETY PIN NOT TO BE REMOVED UNTIL SCREW IS STOWED IN ANCHOR PISTOL.
IF BOMB IS NOT RECEIVED, THE SCREW PIN MUST BE REMOVED WHEN ACED. P. 10.

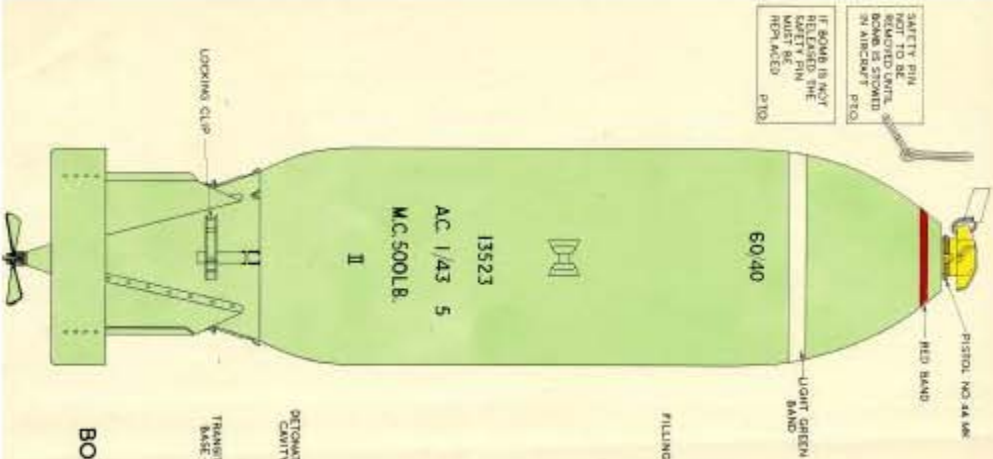

BOMB HE MC 500LB MARK II

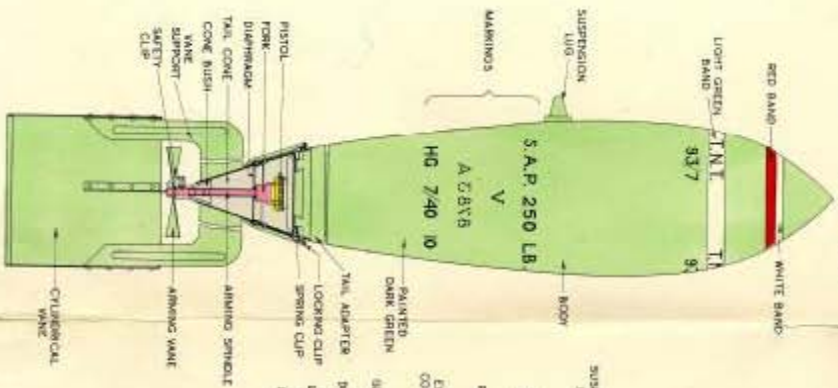

BOMB HE S.A.P. 250LB MARK V

END VIEW OF CYLINDRICAL WANE

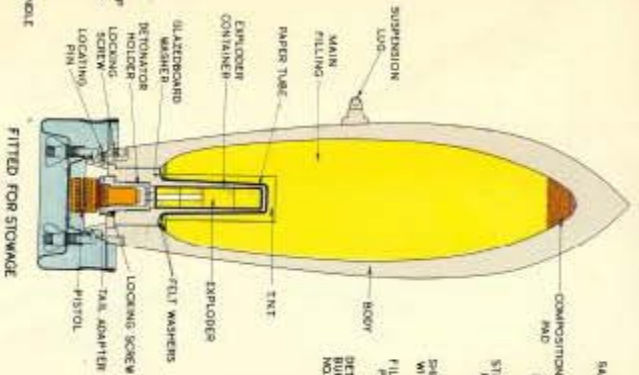
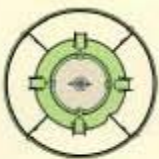

PRACTICE BOMB 10LB MARK I

END VIEW OF CYLINDRICAL WANE

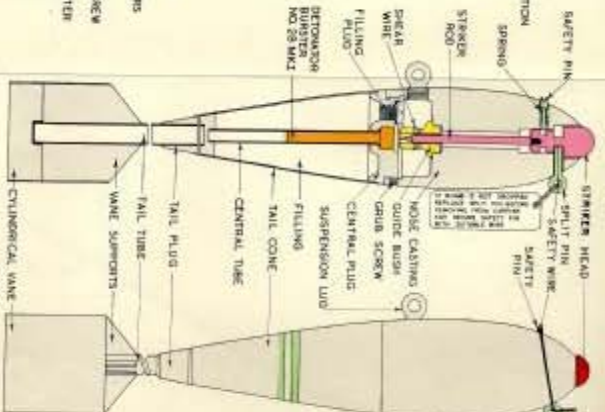

**FUZE, PERCUSSION, AIRCRAFT BOMB, TAIL,
NO. 30 MARK III**

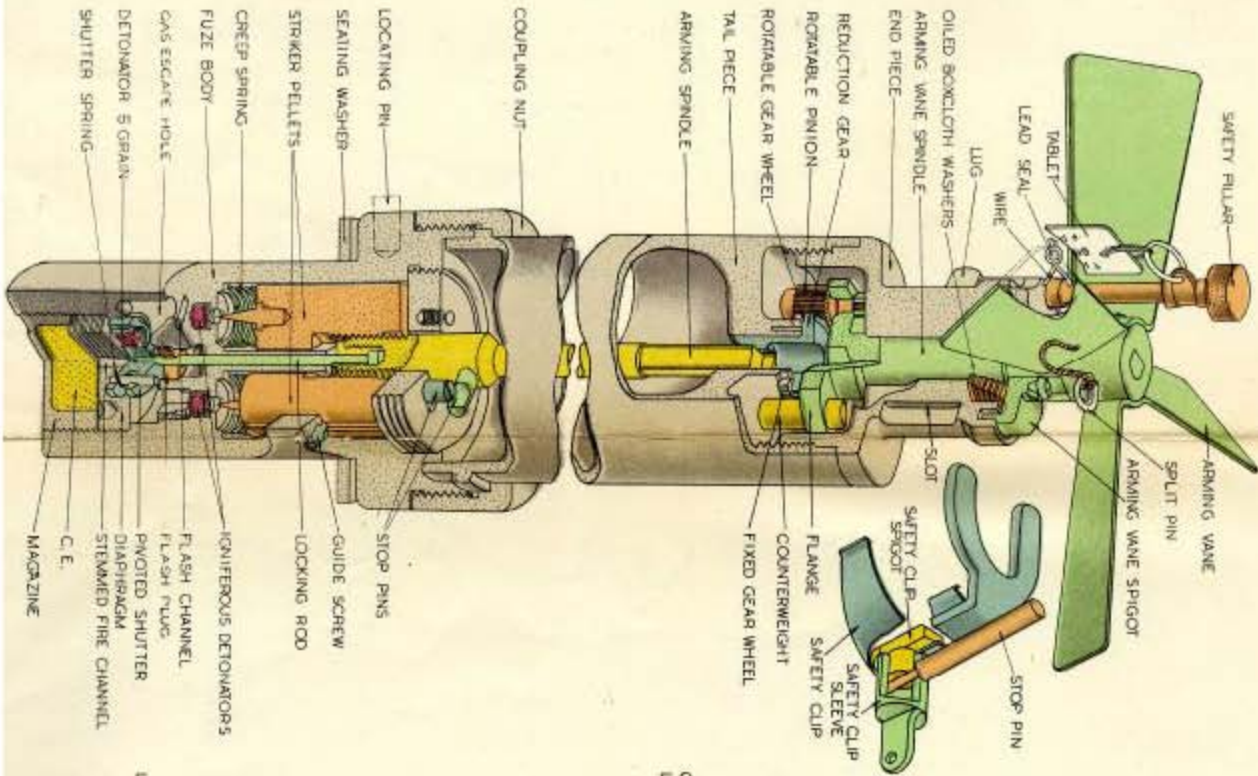

PISTOL, BOMB, TAIL, NO. 30 MARK III

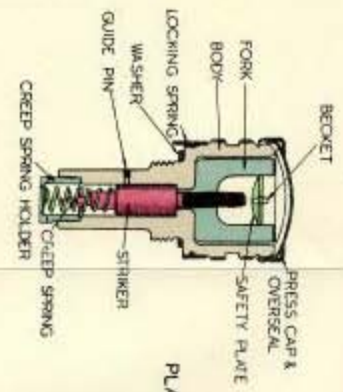

PLAN OF PISTOL WITH PRESS-CAP AND OVERSEAL REMOVED



PISTOL, BOMB, DA, NO. 27 MARK I, I, AND II

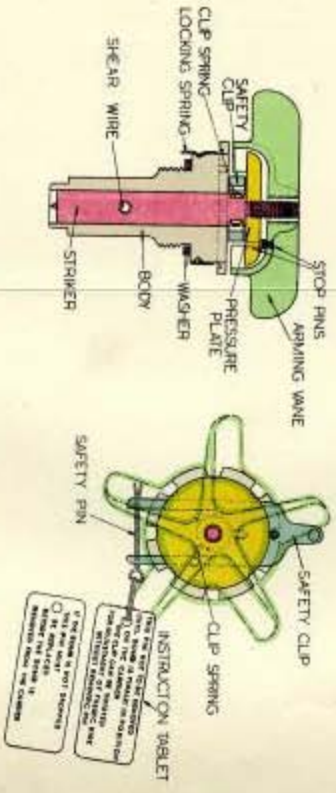

PISTOL, BOMB, DA, NO. 44 MARK I

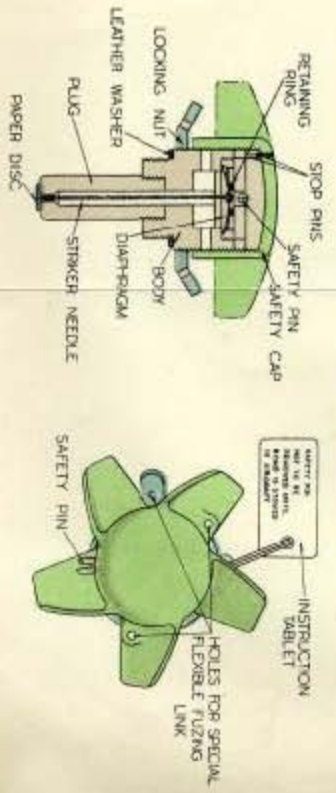

CASES FOR B.L. CHARGES

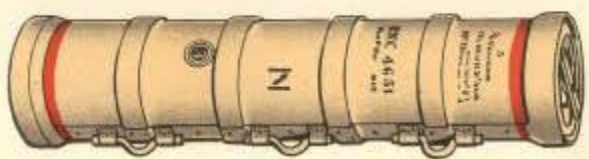

CASE, MAGAZINE, C. E.



CASE, MAG. CF. MK. II

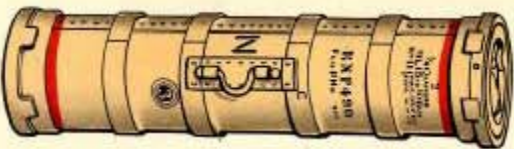

CASE, POWDER, CYLINDRICAL 'M'



CASE, CARTRIDGE NO. 65 MARK III

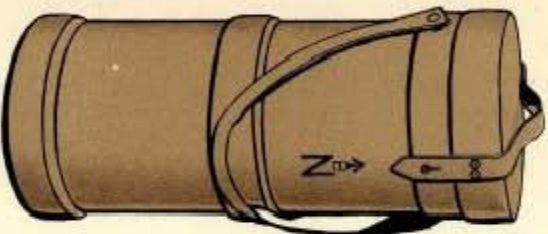

CASE, CARTRIDGE NO. 75 MARK I



CASE, CARTRIDGE NO. 72 MARK I

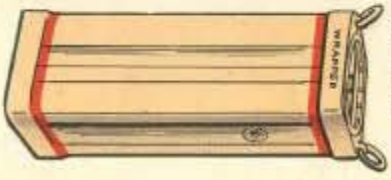

CASE, MAG. R.H. MK. II

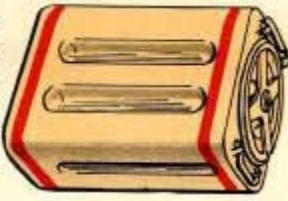

CASE, MAG. R.M. MK. III

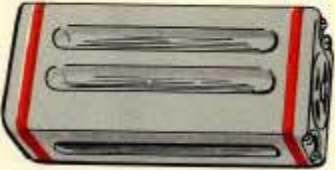

CASE, MAG. R.N. MK. I.N.



CASE, POWDER, RECTANGULAR W MKS. III AND IV

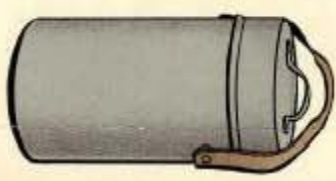

CASE, CARTRIDGE NO. 74 MARK I



8 INCH BOXCLOTH WRAPPER

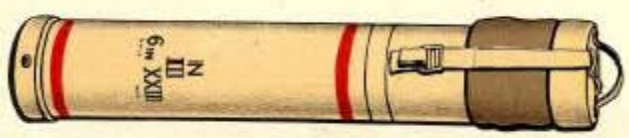

CONTAINER, CARTRIDGE B.L. 6 INCH MARK III

CLARKSON'S CASES AND CONTAINERS FOR B.L. CHARGES



CARTRIDGE AND AMMUNITION BOXES

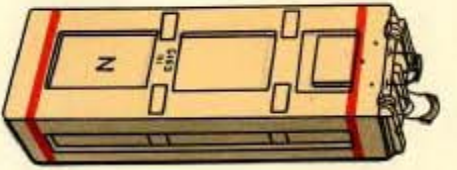

C.163

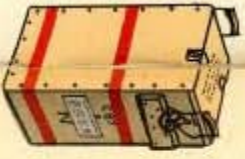

C.17

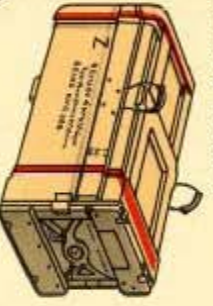

C.23



C.190

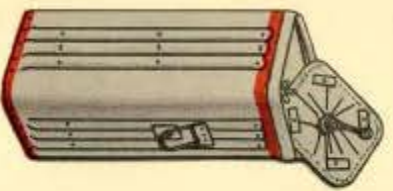

C.185

SCALE - FEET
0 2

CONTAINERS FOR Q. F. AMMUNITION

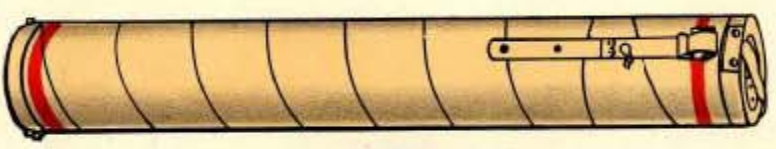

CONTAINER Q. F. 45
MARK III C.217

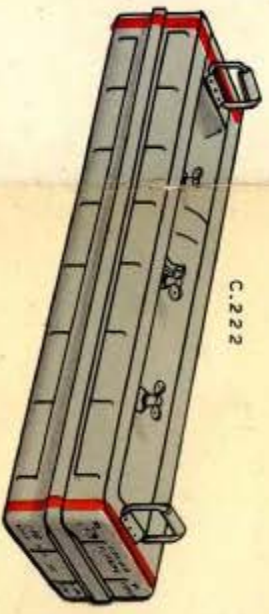

C.222



C.227

SCALE - FEET
0 2

BOXES A.S.A. AND CASES M.L.

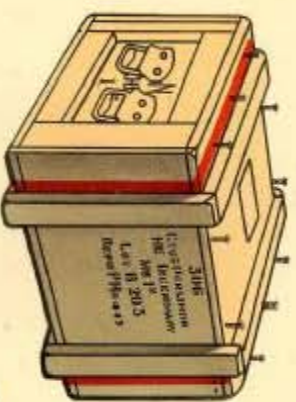

H.33

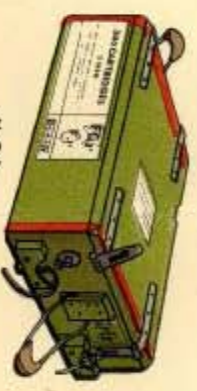

H.24



H.4



H.3 MK. I

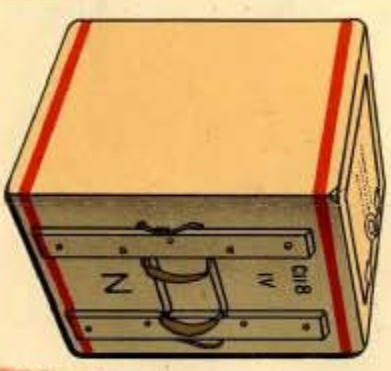

C.118

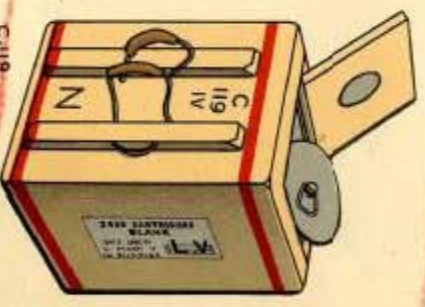

C.119



C.121 MK. I

SCALE - FEET
0 2

6 IN MAGAZINE AND HANDING ROOM
HMS NEWCASTLE

FLOODING AND SPRAYING ARRANGEMENTS

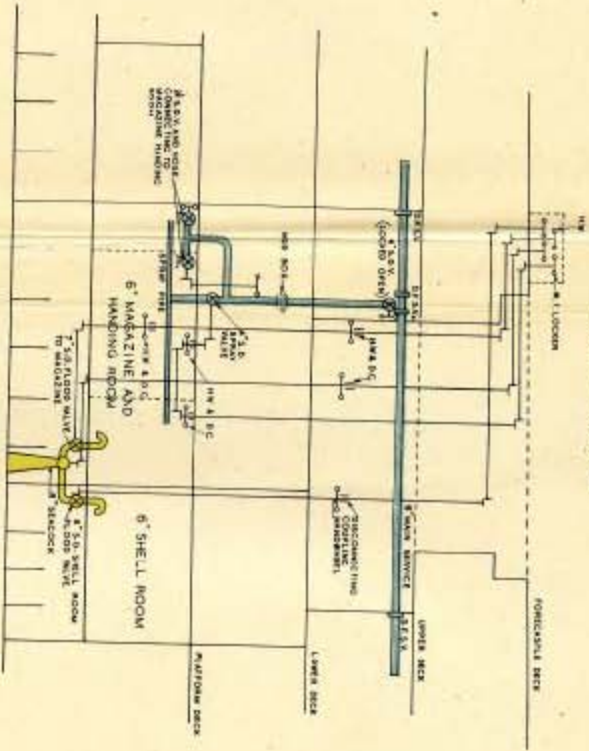

PART PROFILE

6 IN MAGAZINE AND SHELL ROOM
'FUJI' CLASS

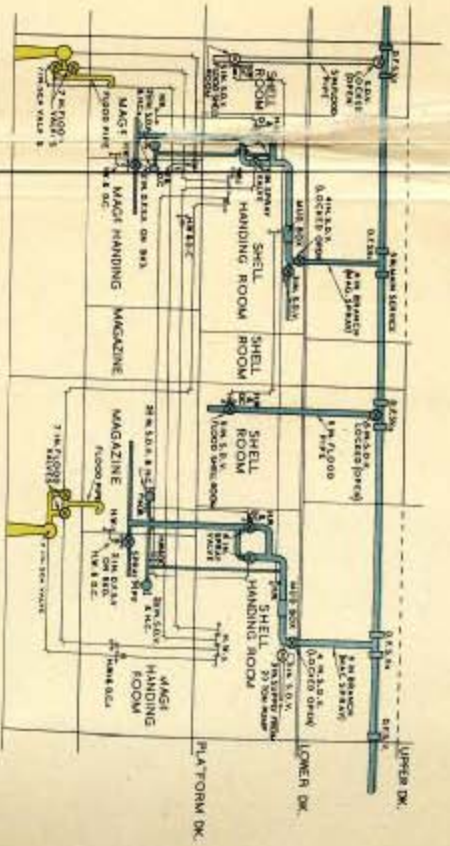

PART PROFILE

NOTE: THE TRIN FLOOD & SPRAY VALVES SHOWN ARE FITTED IN ORDER TO OBTAIN THE UNMILITARY ROD GEARING WHICH WOULD BE REQUIRED IF NO VALVES WERE FITTED

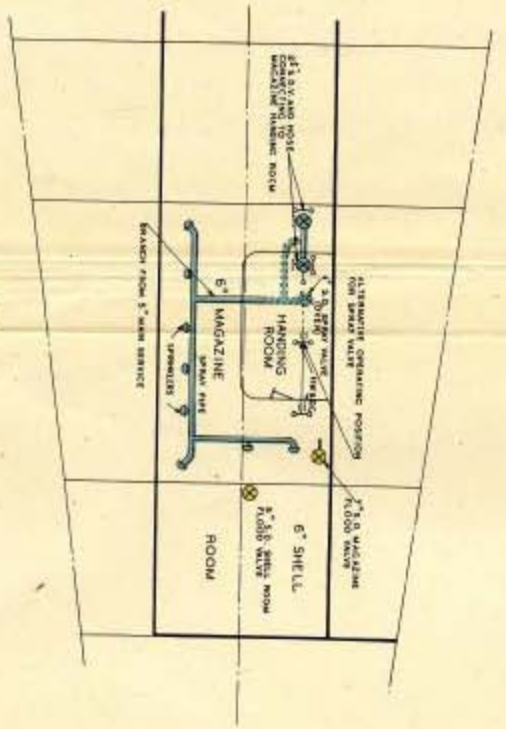

PLAN

O.F.S. - OVERBOARD FLOOD RELIEF VALVE
S.S. - STEER ROOM VALVE
H.W. - HANDWHEEL
D.C. - DISCONNECTING COUPLING

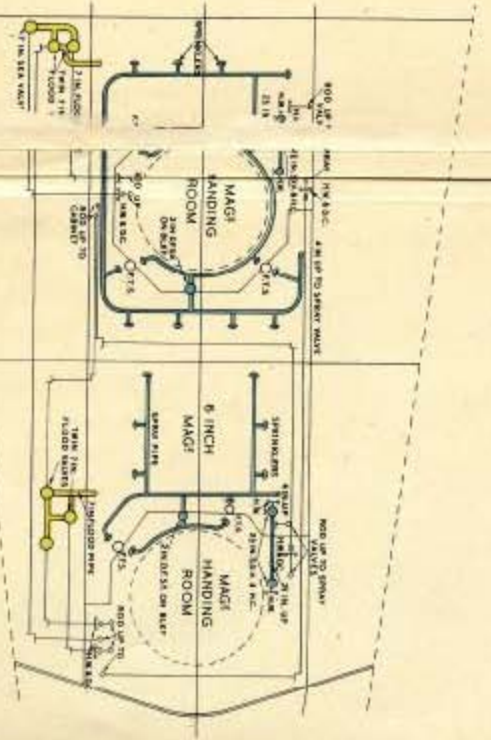

S.D. - SCREW DOWN VALVE
D.F.I. - DOUBLE FACED SLUICE VALVE
H.W. - HANDWHEEL
D.C. - DISCONNECTING COUPLING

H.C. - HOSE CONNECTIONS
F.T.S. - FLASH TIGHT SCUTTLE

14 INCH MAGAZINE AND SHELL ROOM, KING GEORGE V CLASS

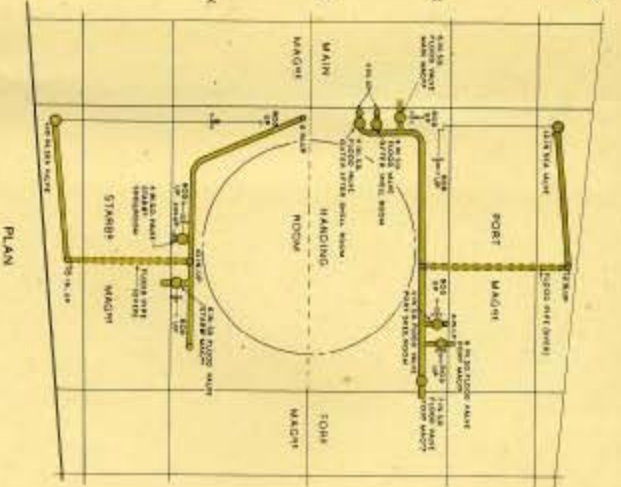
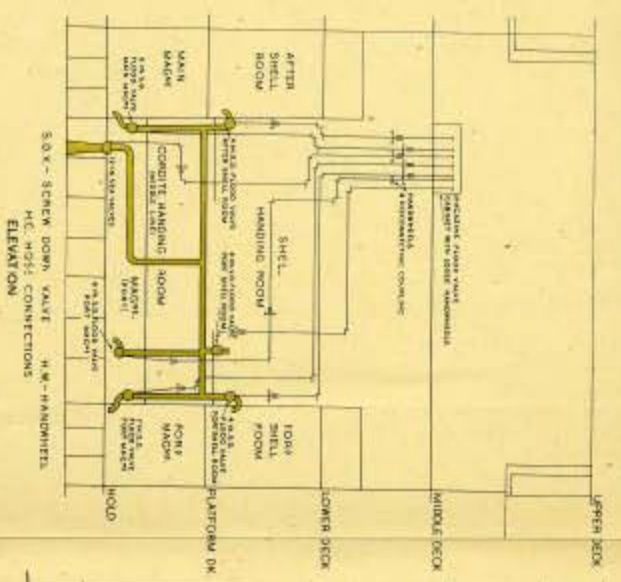

SPRAYING ARRANGEMENTS
14 INCH MAGAZINE AND HANDLING ROOM, KING GEORGE V CLASS

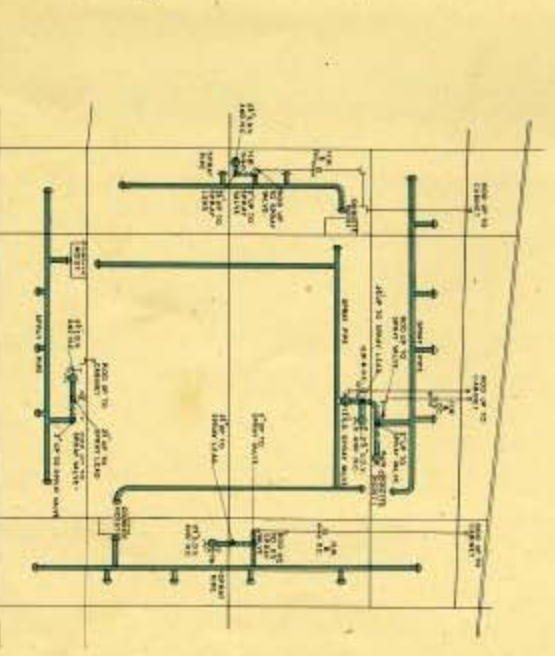
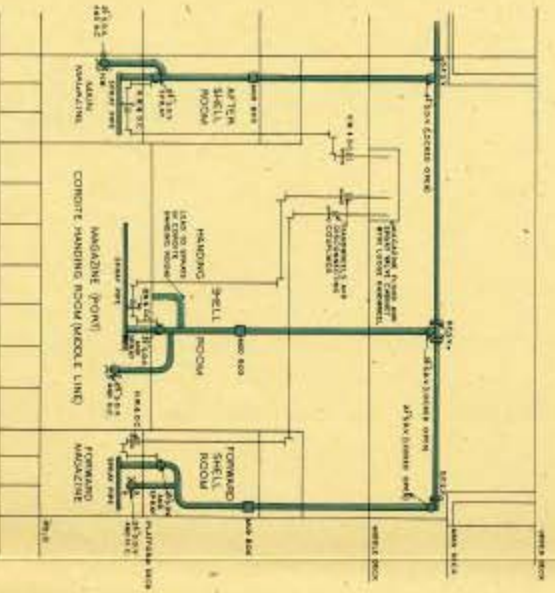

D.T.V. - DOUBLE TAPER SLUICE VALVE
S.O.V. - SCREW DOWN VALVE
ELEVATION

H.W. - HANDWIPEL
D.C. - DISCONNECTING COUPLING

H. - SPRINKLERS
PLAN

14 INCH MAGAZINE STORAGE ARRANGEMENTS "KING GEORGE V" CLASS

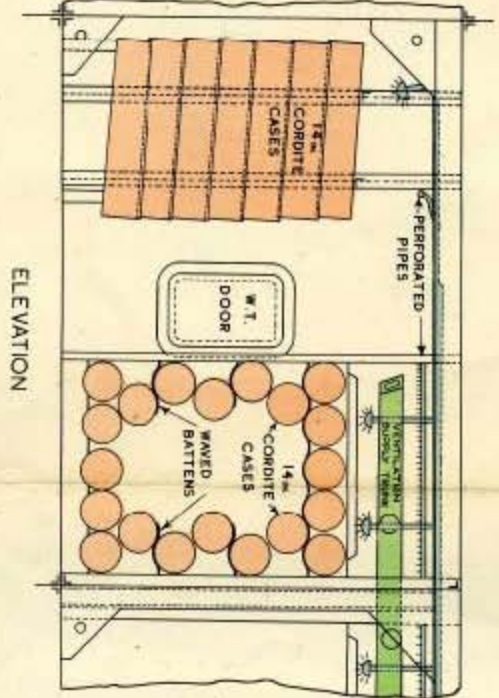
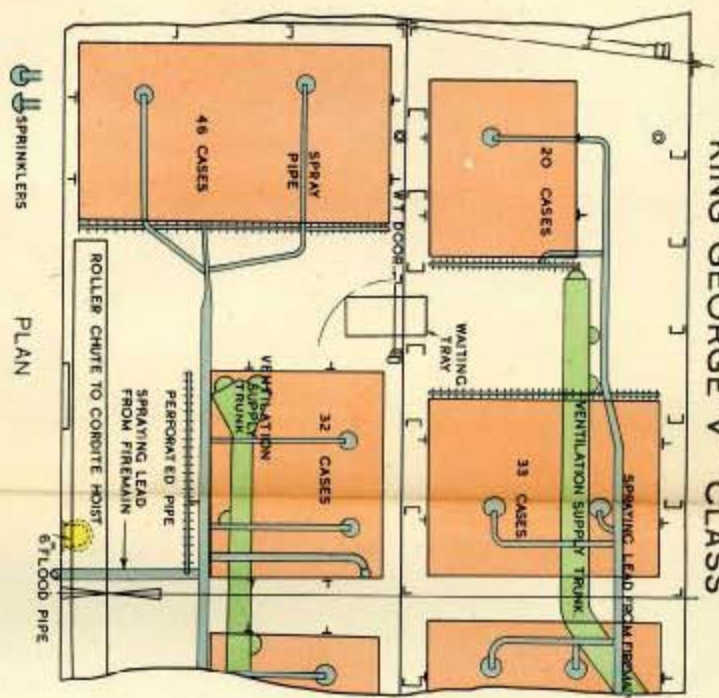

POM-POM MAGAZINE

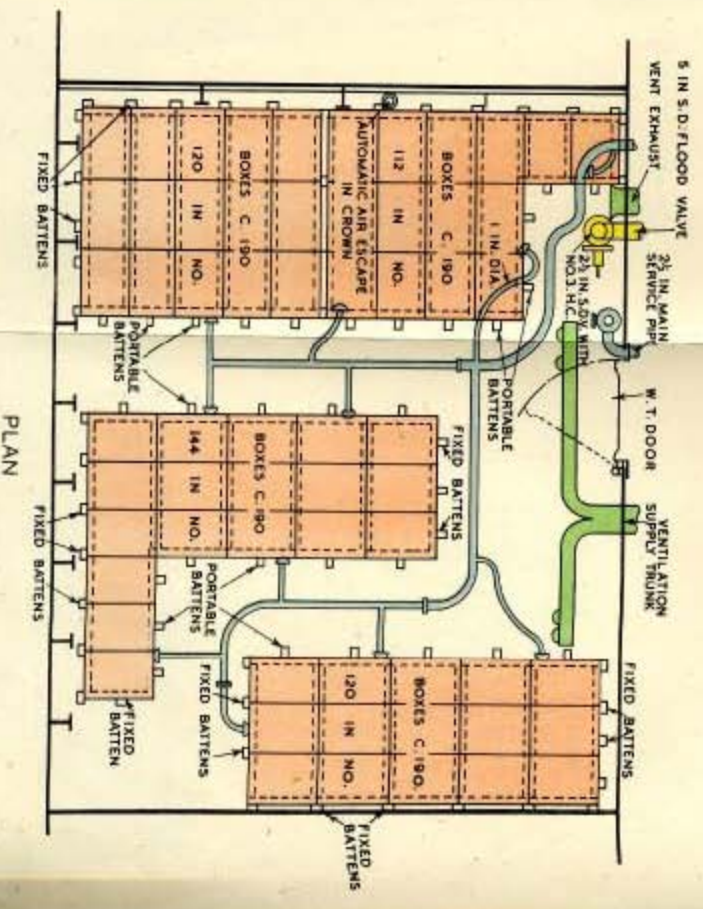
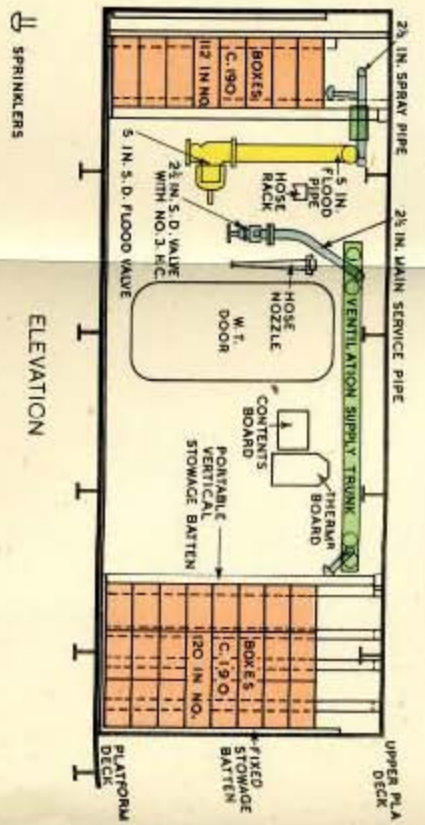

6 INCH MAGAZINE STORAGE ARRANGEMENTS
"SOUTHAMPTON" CLASS

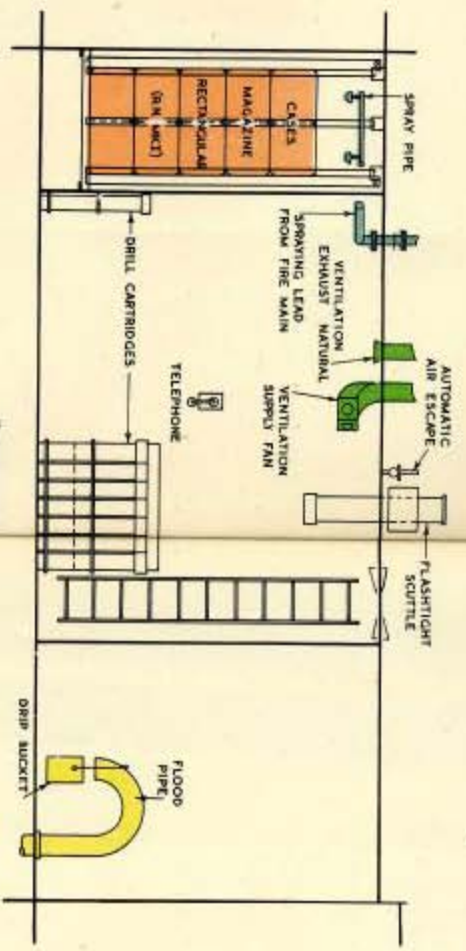

ELEVATION

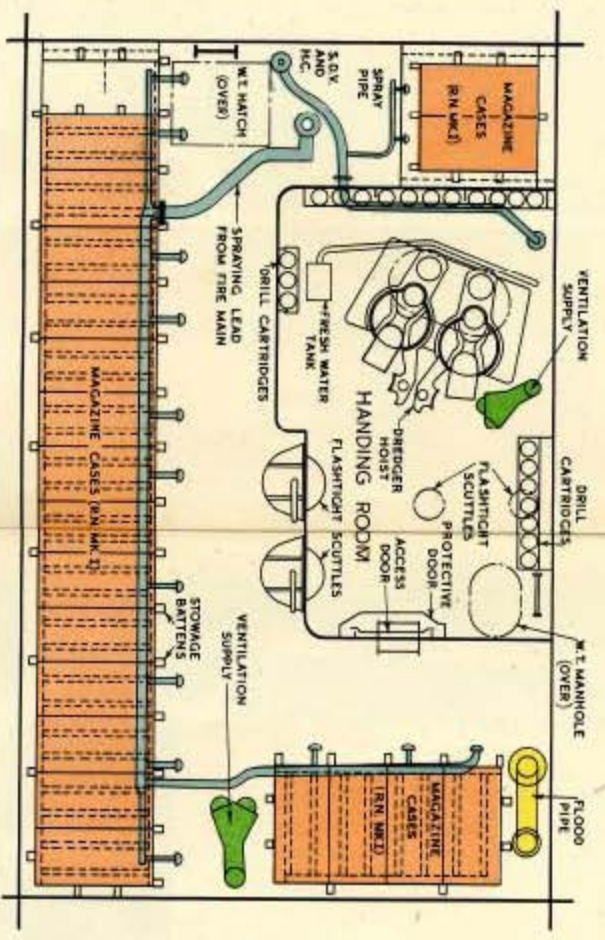

PLAN

BOTTLE RACK STORAGE Q.F. 4 INCH MAGAZINE
"ALGERINE" CLASS

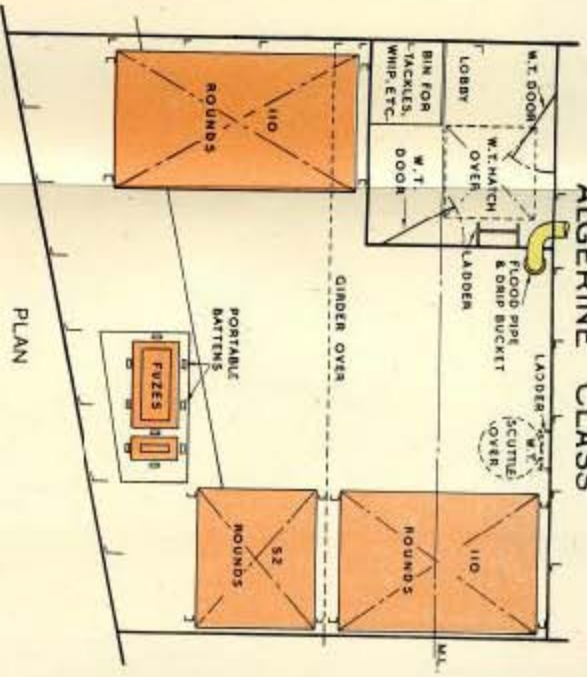

PLAN

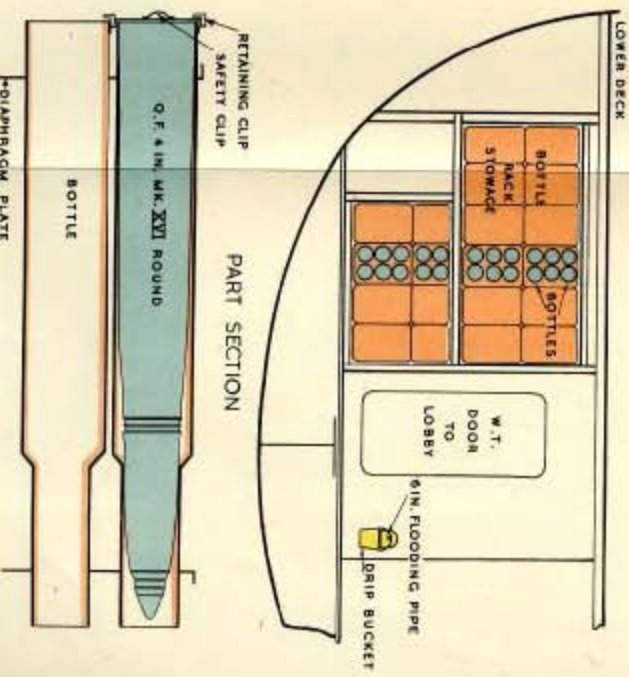

PART SECTION

LOWER DECK

MAGAZINE VENTILATION, AIR COOLING AND DRYING, - DIAGRAMMATIC ARRANGEMENT

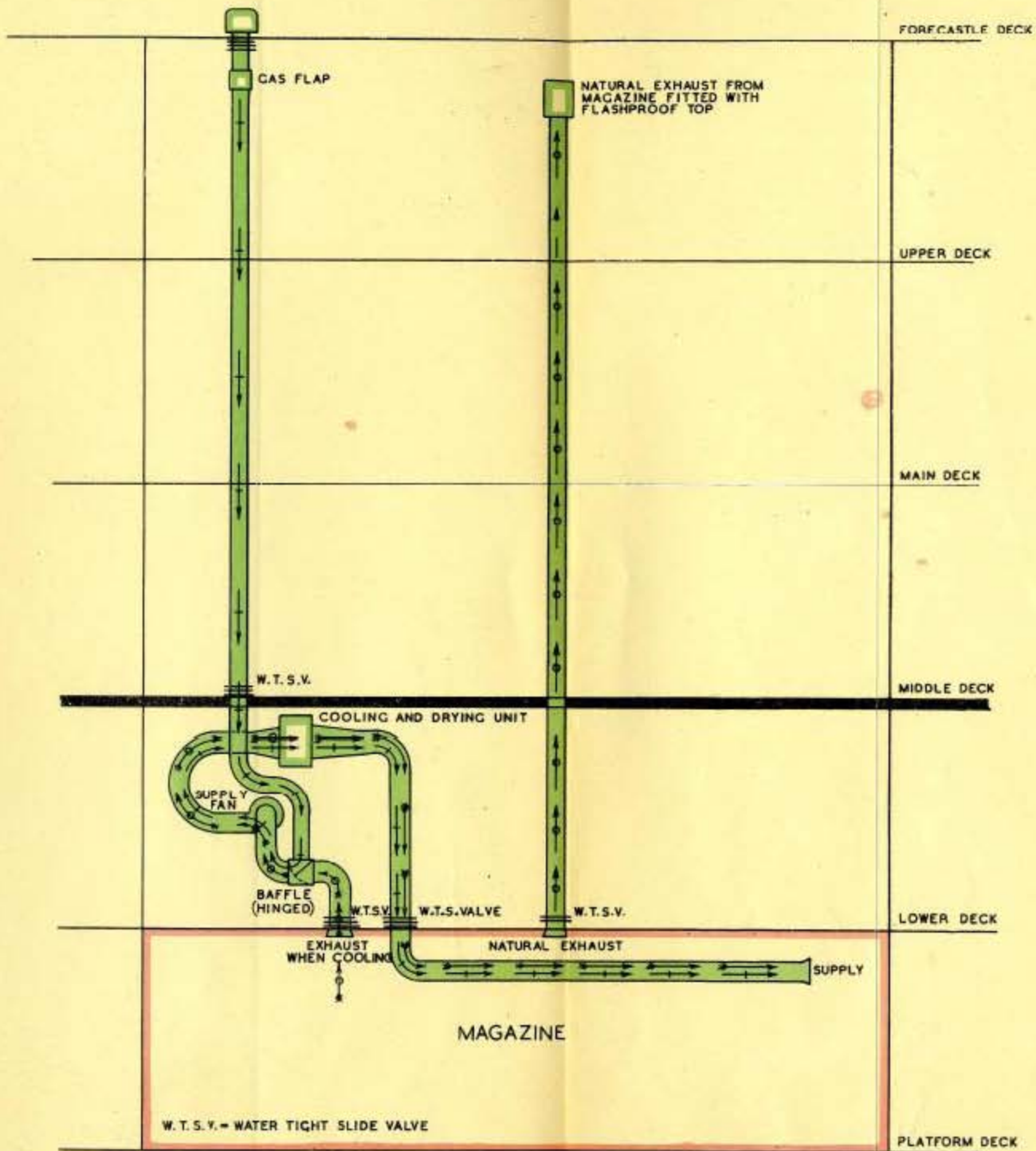

NORMAL VENTILATION

{ OPEN AIR SUPPLY WITH ORDINARY VENTILATION SHOWN THUS
NATURAL EXHAUST " " " " " " " "



AIR COOLING AND DRYING

{ SUPPLY TO MAGAZINE WHEN OPERATING ON CLOSED CIRCUIT
EXHAUST " " " " " " " "

